

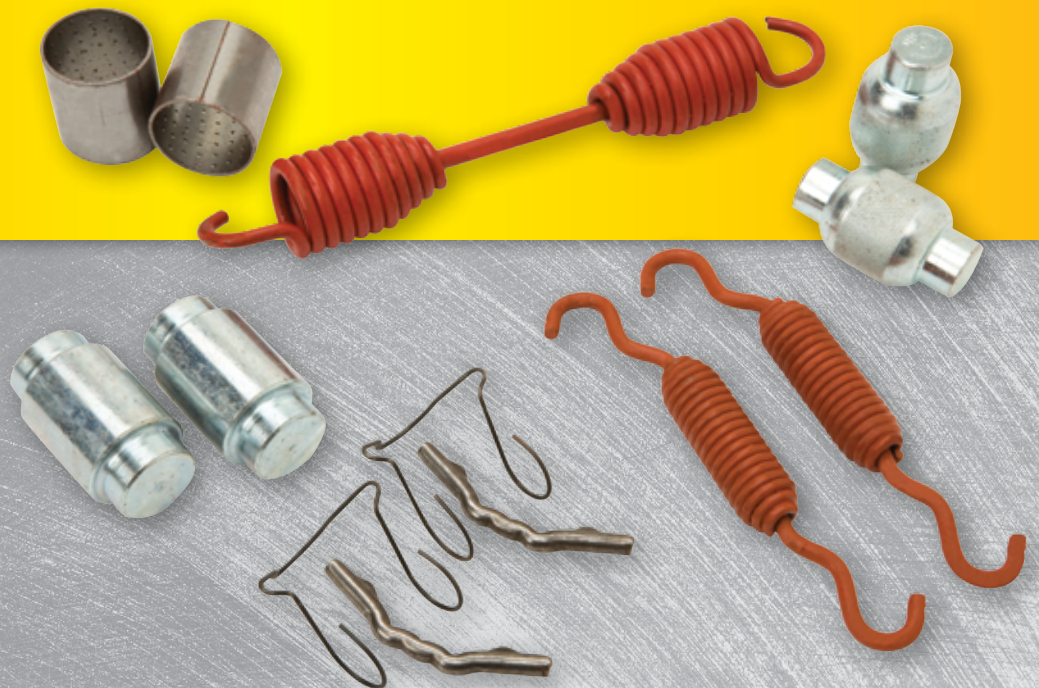

# BRAKE HARDWARE KITS



# EUCLID BRAKE HARDWARE KITS



## EUCLID ADVANTAGES

---

- Delivers both proven stopping performance and extended brake life to reduce maintenance costs
- All parts tested by Meritor to OE replacement specifications
- All parts engineered to manage the brake forces generated for superior performance
- Built-in technology leadership you expect from a global leader in brake manufacturing
- Proven quality control
- XpresswayPlus.com offers:
  - Expert technical support 24/7
  - Order entry/tracking
- Competitively priced to meet your needs
- Leading aftermarket warranty
- For total customer support, call our Customer Care Center 888.725.9355 or in Canada, 800.387.3889

## GENUINE BRAKE HARDWARE KIT COMPONENTS

### Anchor Pins

Euclid anchor pins are case-hardened for longer life. Euclid MEGA PLUS™ anchor pins are hard chrome or zinc plated for corrosion resistance.



Euclid STOPMATE PLUS™ pins are zinc plated for maximum corrosion resistance.

All Euclid anchor pins provide a close fit between pin and shoe, yet allow the shoe to move freely.

### Brake Shoe Rollers

Euclid “Posi Plus” shoe rollers add smooth radius edges to prevent flatspotting on the roller surface. When uneven brake cam pressure occurs, pressure is distributed evenly across the radius-edge surface of the roller to prevent cracks that lead to flat spots.



Euclid “Posi Plus” brake shoe rollers are included in MEGA PLUS and STOPMATE PLUS hardware kits.

### Stainless Steel Anchor Pin Bushings

Euclid MEGA PLUS high-grade stainless steel anchor pin bushings feature an exclusive “dimpled” inner surface, which retains lubricant for easier pin removal.



Euclid STOPMATE PLUS kits feature high-grade stainless steel for corrosion resistance.

### Brake Return Springs

Shot peening removes surface flaws – important under stress, since any flaws or forming marks become the weakest part of the spring. High-grade wire retains high spring tension for durability.



Euclid MEGA PLUS kits feature only heavy-duty 100-pound tension return springs.

### Wire Roller Retainer

Coated to guard against corrosion, which can cause the brake shoe rollers to bind and accelerate camshaft wear.



## UNMATCHED SERVICE AND SUPPORT



For complete product information, visit [XpresswayPlus.com](http://XpresswayPlus.com), our industry-leading online catalog, ordering and tracking system with real-time access to comprehensive parts information resources, including a reference library with complete technical drawings on components and systems.

Our highly trained Customer Care team is equipped with the product specification, warranty and service information needed to deliver the best customer support. Call them at 888-725-9355 or in Canada, call 800-387-3889.



**Meritor Heavy Vehicle Systems, LLC**

7975 Dixie Highway  
Florence, KY 41042 USA  
USA 888-725-9355  
Canada 800-387-3889

**meritor.com**  
XpresswayPlus.com

**Distributed by:**

Information contained in this publication was in effect at the time the publication was approved for printing and is subject to change without notice or liability. Meritor reserves the right to revise the information presented or discontinue the production of parts at any time.

Litho in USA  
Revised 02-12  
SP-0774  
©2012 Meritor, Inc.

# MERITOR® ALLFIT SIMPLECHECK™ BRAKE STROKE TOOL.



**MERITOR**



 **IDEAS DRIVING RESULTS**  
THE FAST AND EASY WAY TO  
CHECK AIR BRAKE STROKE.

  
**ALLFIT**



## With SimpleCheck™, Brake Checks Are Simple, And Installation Is Easy.

With the new Meritor AllFit SimpleCheck tool, drivers can quickly check air brake stroke. Just one look, and drivers know whether the brake system needs attention, which makes it much easier to run safe and meet Compliance, Safety, Accountability (CSA) and Federal Motor Carrier Safety Administration (FMCSA) regulations. And SimpleCheck is easy to install on any cam brake air chamber.

## C.Y.A. With The Little Green Tool That Can Save You Big Green.

For complete vehicle coverage, install SimpleCheck at each air brake chamber. Complete tractor coverage requires the installation of up to six SimpleCheck discs. Complete trailer coverage requires the installation of up to four SimpleCheck discs. Each SimpleCheck package contains a total of 10 discs.

Cover Your Assets by installing SimpleCheck at every air brake chamber in every vehicle and/or trailer in your fleet. Installation information is available at [MeritorCYA.com](http://MeritorCYA.com).

There are four sizes available, depending on the size of the clevis thread and outside diameter. The part numbers for the appropriate thread and outside diameter are as follows:

Part Number	Fits Clevis Thread	O.D.
M820625	5/8" – 18	1.75
M820750	3/4" – 16	1.75
M810500	1/2" – 20	1.38
M810625	5/8" – 18	1.38

## How SimpleCheck Works.

**What:** SimpleCheck is a green disc used as a marker to visually inspect applied chamber stroke on cam brake-equipped vehicles.

**Where:** When the brake is fully released, the SimpleCheck disc is installed on the pushrod at the base of the air brake chamber (as shown below).



**How:** When the brake is applied (via service air pressure or parking brake spring pressure), the disc indicates how far the pushrod travels.

**Inspection:** If the SimpleCheck disc travels less than or equal to the length of the standard 1½-inch brake chamber stud, the pushrod stroke is acceptable (as shown below).



If the SimpleCheck disc travels beyond the end of the brake stud (as shown below), then further brake system diagnostics must be performed. It's that simple – and that fast.



For more information, or to download the complete Meritor AllFit SimpleCheck installation instructions, visit [MeritorCYA.com](http://MeritorCYA.com).

# BRAKES

## MODULE ONE



## BRAKE JOB CRITICAL-REVIEW COMPONENTS

### Brake Drums

- The maximum allowable brake drum diameter is stamped or cast into the outer edge of the drum. Place a brake drum diameter gauge inside the drum. Take several measurements within 90 degrees of each other at the open and closed edges of the drum's friction surface
  - If any of these measurements are 0.120-inch, replace the brake drum
  - If a brake drum is out-of-round, replace the drum



### Slack Adjusters

- Verify the retaining bolt or snap ring is correctly secured in the camshaft
- Check slack adjuster gear torque – use a lb-in torque wrench and turn adjusting nut counterclockwise
  - If the torque value is less than 45 lb-in as you rotate gear, slack adjuster is operating correctly
  - If the torque value exceeds 45 lb-in as you rotate gear, replace slack adjuster



### Shoes/Linings

- Measure lining wear. Linings must have a greater than ¼" thickness at the center of the brake lining. Inspect for cracks, separation from the brake shoe table, and loose rivets
- Always use new brake shoe hardware – rollers, roller retainers and return springs
- Inspect camshafts and camshaft bushings for wear
- RSD brake assemblies must be serviced with RSD brake shoe and lining assemblies to maintain braking capability. Use of non-RSD friction material could negatively impact the safe operation of the vehicle
- Replace all wheel seals



# TECH TIPS

### Includes:

- Brake Drums
- Slack Adjusters
- Shoes/Linings
- Brake Chambers
- Camshafts



## Brake Chamber

- Check brake chamber for looseness or damage
- Ensure retaining nuts are tightened to specification
- Verify push rod is exiting the chamber at a 90 degree angle and it returns completely after each brake application
- Verify chamber size (20, 24, 30 etc.) and the chamber type – either standard or long stroke – are the same on each side of axle
- Inspect the chamber bracket for cracks and damage
- Verify the caging bolt, nut and washer are installed, and the caging bolt cover is secure



## Camshafts

- Before removal of the automatic slack adjuster and camshaft, verify that cam-to-bushing radial free play is within spec
- Check the camshaft for cracks, wear or corrosion. Check the cam head bearing journals and splines. Replace worn or damaged camshafts. Install new bushings and seals whenever you install a new camshaft
- The bushing wears in one direction; it is important to rotate the camshaft in all directions when checking for radial free play
  - If radial free play is less than 0.030" (0.76mm) – do not replace bushing and seals
  - If radial free play is more than 0.030" (0.76mm) – replace bushings and seals



# CAM BRAKE TORQUE SPECIFICATIONS

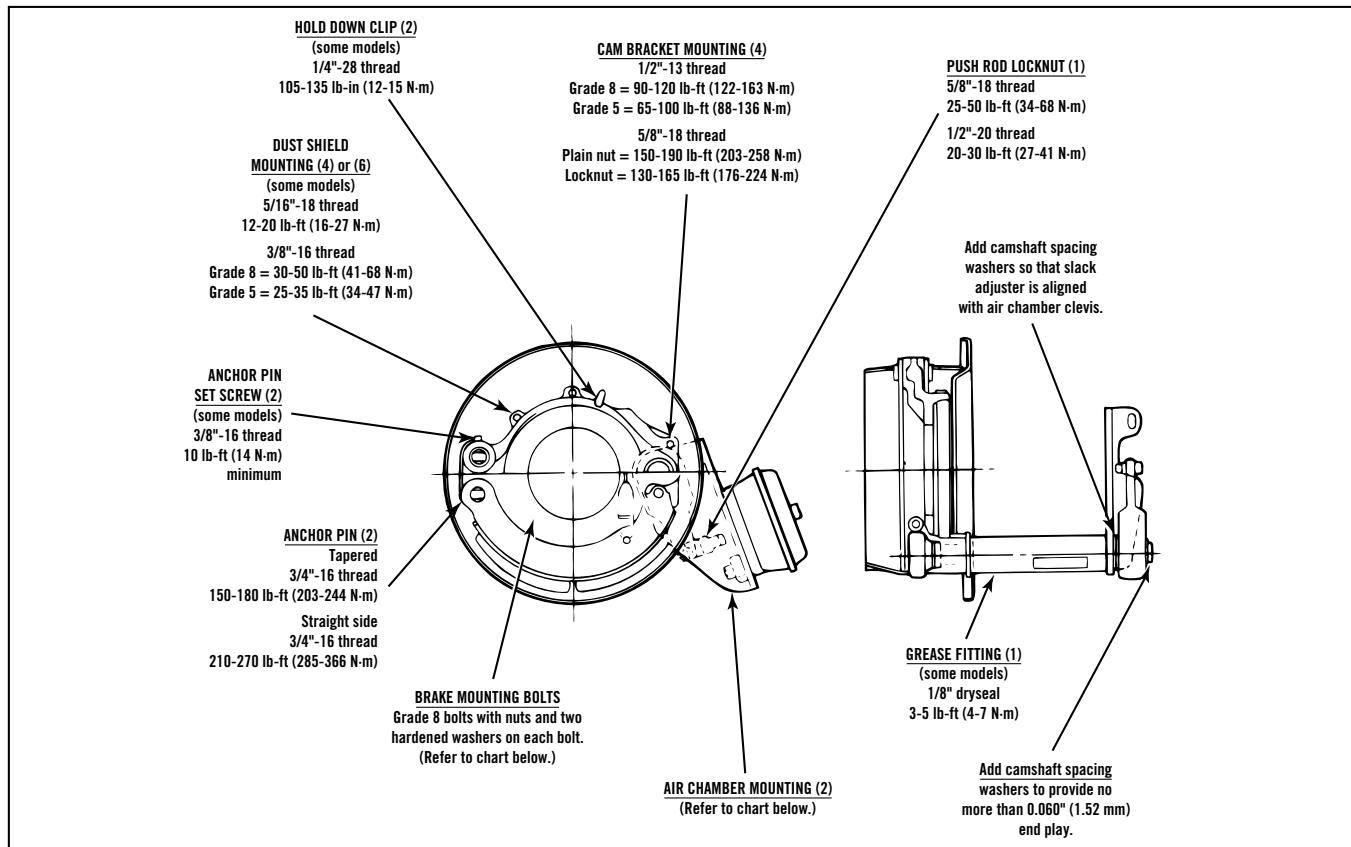



# MERITOR® STROKE SENSING AUTOMATIC SLACK ADJUSTERS FOR THE AFTERMARKET



**MERITOR**



## **IDEAS DRIVING RESULTS**

GENUINE PRODUCT PROVEN IN  
HUNDREDS OF BILLIONS OF  
SERVICE MILES.





ASA and clevis sold separately.

## **MERITOR® AUTOMATIC SLACK ADJUSTERS. KEEPING TRUCKS ON THE ROAD LONGER.**

*As the leading North American supplier of braking systems, Meritor understands the delicate relationship between Automatic Slack Adjusters (ASA) and foundation brakes. Our genuine Meritor ASAs have been proven in hundreds of billions of miles on the road. So when it's time to replace a vehicle's ASAs, why choose anything other than the original equipment?*



# UNIQUE DESIGN OFFERS OPTIMUM BRAKE PERFORMANCE.

Our unique design keeps brakes in constant adjustment while eliminating the need for frequent under-the-truck brake adjustments. With the Meritor ASA, brake maintenance costs and vehicle safety inspections are reduced while allowing for optimum brake performance.

## Proven Performance Benefits.

- Keep brakes in constant adjustment
- Eliminate the need for frequent under-the-truck brake adjustments
- Reduce brake maintenance costs
- Reduce vehicle safety inspection citations
- Allow optimum brake performance

## Low-Maintenance, Long-Life Design.

- No external brackets required
- Simple, durable design
- Fewer moving parts – no slip clutches to wear out
- Pull pawl eliminates need to remove pawl during manual brake adjustment
- As a safety precaution, the manual adjusting nut cannot be inadvertently backed off
- Threaded grease fittings for easy serviceability
- Lubrication holes and groove help eliminate corrosion and seizing up, and result in easier servicing
- Redesigned housing features improved pressed-in and sealed actuator boot

Specifications				
	Slack Length (Inches)	Camshaft Spline Size and Number	Clevis Configuration	Clevis Thread*
Front Steer Axles	5, 5.5 and 6	1.25 - 10 1.25 - 24 1.5 - 10 1.5 - 28	Straight or 0.625 Offset	0.5 - 20 0.625 - 18
Drive and Trailer Axles (and front steer axles with larger air chambers)	5, 5.5, 6, 6.5 and 7	1.5 - 10 1.5 - 28 1.625 - 37	Straight	0.625 - 18

\* Metric threads available



## Meritor Stroke Sensing ASA Warranty Coverage.

Application	Years	Mileage
Linehaul	5	500,000
General Service	3	Unlimited
Heavy Service	3	Unlimited
Off-Highway Service	3	Unlimited

Refer to publication SP-95155 for full vehicle application details.

# HOW THE MERITOR AUTOMATIC SLACK ADJUSTER WORKS

An ASA is vital to optimum brake performance. The ASA adjusts the brake as it wears and helps ensure the air brake chamber can produce enough actuation force by adjusting the amount of slack, or free play, in the brake. This adjustment is critical in air brakes because with too little slack, the brake may drag and overheat. If there is too much slack, the brake may not generate enough braking effort to safely stop the vehicle. The two phases of adjustment – the Actuation Phase and the Adjustment Phase – work together to provide ideal brake adjustment in order to deliver optimum brake torque to stop the vehicle.

## The Actuation Phase.

When the brakes are first actuated...

1. The air brake chamber pushrod moves the slack adjuster outward to apply the brake.
2. The change in geometry between the chamber pushrod and slack lever arm raises the slack adjuster actuator rod.
3. The internal piston contacts the retaining ring which lifts the actuator.
4. The actuator has spiral serrations on it which jump over the serration on the pawl, only if the adjustment is required.
5. The components remain in the position until the start of the return stroke.

## The Adjustment Phase.

1. On brake release, the returning movement of the air brake chamber pushrod and slack lever arm forces the actuator rod, ASA piston and actuator downward.
2. Contact between the pawl and actuator teeth cause the actuator to rotate.
3. The rotation of the actuator in its downward travel causes the worm gear to rotate.
4. The rotation of the worm gear causes the butress gear to rotate.
5. The butress gear rotates the camshaft so that proper brake adjustment is maintained.





# AUTOMATIC SLACK ADJUSTER PARTS AND INSTALLATION

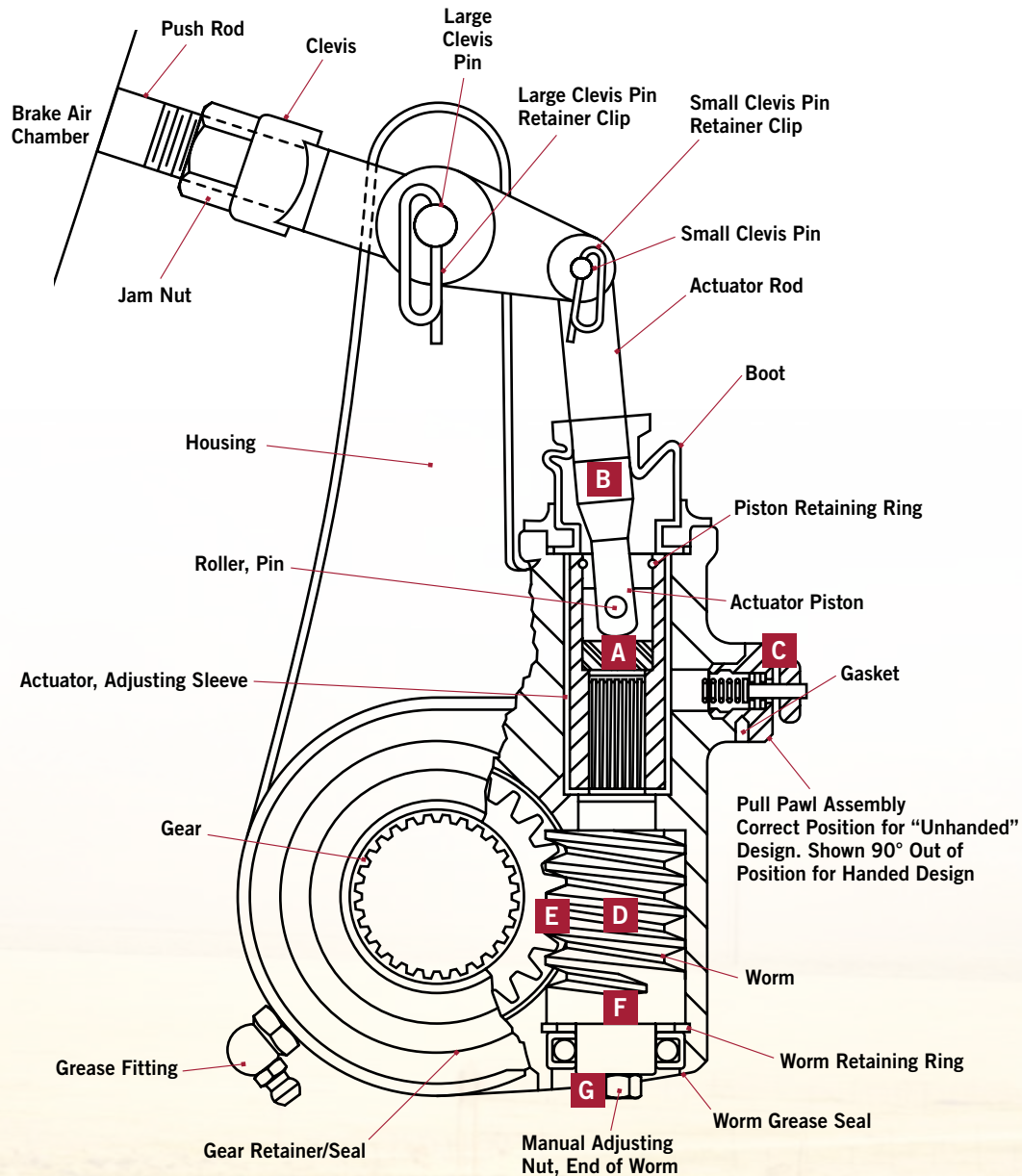

Features	Benefits
<b>A</b> Variety of Pistons	Adapt to unique vehicle vocations and duty cycles
<b>B</b> Sealed Boot	Press-in and sealed for maximum durability
<b>C</b> Fool-Proof Pull Pawl	Design eliminates the need to remove pawl for manual brake adjustment Built-in safety feature so brake cannot be inadvertently backed off
<b>D</b> High-Strength Worm Gear	Buttress type provides increased strength for longer life <ul style="list-style-type: none"> <li>■ Lubrication hole and groove provide lubrication to splines, helping eliminate corrosion and seizing up, and resulting in easier servicing</li> </ul>
<b>E</b> Anti-Contaminant Gear Face Seals	Help decrease internal contamination and corrosion, minimizing internal torques <ul style="list-style-type: none"> <li>■ Eliminate sensitivity to external factors such as paint, road debris, etc., resulting in reduced internal torques</li> </ul>
<b>F</b> Water-Tight Worm Seal	Worm seal prevents water from gaining access to worm gear shaft
<b>G</b> Safety-Enhancing Manual Adjusting Nut	As a safety precaution, manual adjusting nut cannot be inadvertently backed off

# SPEC THE RIGHT MERITOR CLEVIS FOR THE APPLICATION.

Utilizing the correct Automatic Slack Adjuster (ASA) clevis is critical to maximizing brake life. The use of an incorrect clevis could result in an increase to operating costs.



Meritor ASAs are sold in the aftermarket less clevis which allows the end user to properly spec the clevis for the intended application. Meritor manufactures clevises with pin spacings of 1.30" and 1.38" to accommodate a variety of applications. To maximize brake lining life, it is recommended to replace the clevis when the ASA is replaced.

When it's time to replace the ASA, replace the clevis following the Template Method as outlined here.

## Template Method for Replacing the ASA Clevis.

Measure the old clevis, or if the old clevis is not available, measure the clevis on the opposite wheel end of the axle by matching the two cutouts on the bottom of the template to the clevis holes.

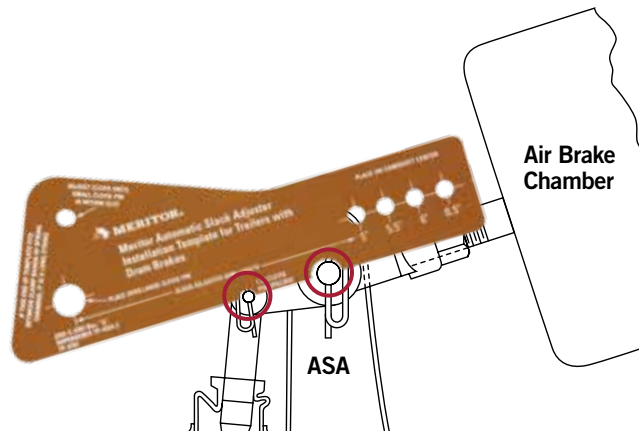

1. Use the correct Meritor ASA template to measure the length of the slack adjuster<sup>1</sup>. The marks by the holes in the small end of the template indicate the length of the slack adjuster.

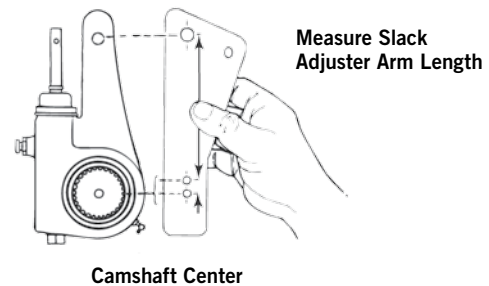

<sup>1</sup> The ASA templates are not interchangeable. The correct ASA template and clevis pin spacing must be used and the clevis position must be adjusted as described in the Template Method. If an incorrect combination is used and the clevis is installed in the wrong position, the slack adjuster will not adjust the brake correctly. If the slack adjuster under adjusts, stopping distances are increased. If the slack adjuster over adjusts, the linings may drag and damage the brake.



TP-4786 ASA template for trucks and tractors with drum brakes with 1.38" spacing<sup>1</sup>



TP-4787 ASA template for trailers with drum brakes. NOTE: Trailer must always use 1.38" spacing<sup>1</sup>



TP-10130 ASA template for trucks and tractors with drum brakes with 1.30" spacing<sup>1</sup>

2. Install the large clevis pin through the large holes in the ASA template and the clevis.
3. Select the hole in the ASA template that matches the length of the slack adjuster. Hold that hole on the center of the camshaft.

4. Look through the slot in the template to see if the small clevis hole completely aligns within the slot.

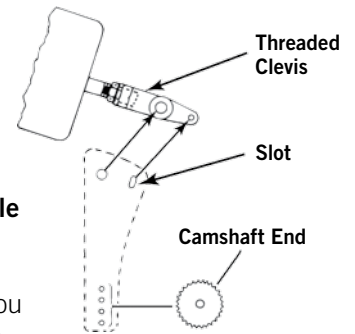

- If the small clevis hole doesn't align within the slot:

Adjust the clevis until you can see the small clevis pin hole within the slot (right).

5. Verify that the thread engagement between the clevis and push rod is 0.5" - 0.625" (12.7-15.9 mm).

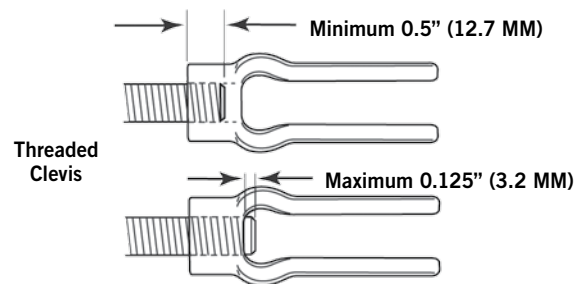

6. Verify that the push rod does not extend through the clevis more than 0.125" (3.2 mm).

- If the push rod extends through the clevis more than 0.125" (3.2 mm): Cut the push rod or install a new air chamber and push rod.

7. Tighten the jam nut against the clevis to the torque specification below. **T**

Thread	Torque
1/2-20	20-30 lb-ft (27-41 N•m)
5/8-18	35-50 lb-ft (48-68 N•m)

**NOTE:** Use either the Template Method\* or BSAP Method\* to ensure the correct position of welded or threaded clevises on standard- or long-stroke brake chambers.

\* For more information on the Template or BSAP Methods, refer to Meritor Maintenance Manual 4, *Cam Brake and Automatic Slack Adjusters*. For information on welded-clevis air brake chambers, refer to the air brake chamber manufacturer's maintenance publication.

## **IDEAS DRIVING RESULTS**

As a world leader in providing aftermarket solutions for the global commercial vehicle and industrial markets, Meritor is committed to providing our customers with innovative aftermarket ideas that deliver the results you need to get the job done faster, better and more efficiently.

Vehicle models, brands and names depicted herein are the property of their respective owners and are not in any way associated with Meritor, Inc., or its affiliates.



Meritor Heavy Vehicle Systems, LLC  
7975 Dixie Highway  
Florence, Kentucky 41042 USA

U.S. 888-725-9355  
Canada 800-387-3889  
MeritorPartsOnline.com  
meritor.com

©2015 Meritor, Inc.  
Litho in USA, SP-15102  
Issued 05-15 (47865/11900)





# Inspection

## Inspecting Commercial Vehicle Foundation Cam Brake Systems

### Wheels On and Wheels Off the Vehicle

### Hazard Alert Messages

Read and observe all Warning and Caution hazard alert messages in this publication. They provide information that can help prevent serious personal injury, damage to components, or both.

#### **WARNING**

**To prevent serious eye injury, always wear safe eye protection when you perform vehicle maintenance or service.**

**Park the vehicle on a level surface. Block the wheels to prevent the vehicle from moving. Support the vehicle with safety stands. Do not work under a vehicle supported only by jacks. Jacks can slip and fall over. Serious personal injury and damage to components can result.**

#### **ASBESTOS AND NON-ASBESTOS FIBERS WARNING**

**Some brake linings contain asbestos fibers, a cancer and lung disease hazard. Some brake linings contain non-asbestos fibers, whose long-term effects to health are unknown. You must use caution when you handle both asbestos and non-asbestos materials.**

### About This Inspection Bulletin

Commercial vehicle foundation cam brake inspection always has been an important part of helping to ensure a vehicle is safe to operate. In an effort to further improve commercial truck and bus safety, the U.S. Department of Transportation's Federal Motor Carrier Safety Administration (FMCSA) launched the Compliance, Safety, and Accountability (CSA) program in December 2010. Together with State Partners and industry, the FMCSA is working to help prevent commercial motor vehicle crashes, injuries and fatalities on our nation's highways.

As the leading manufacturer of foundation cam brake systems in North America, Meritor developed this Inspection bulletin to provide fleets, dealers, owner-operators and repair facilities with preventive maintenance inspection guidelines for commercial vehicle foundation cam brake systems. Included are the mechanical – or foundation – portion of the brake system for wheels-on/wheels-off the vehicle inspections.

Although inspecting the air supply system is not included in this bulletin, it must be performed during a preventive maintenance inspection.

### Only a Qualified Brake Inspector Can Perform Brake Inspections on a Commercial Motor Vehicle

*Any person who performs inspection, maintenance, service or repairs to the brakes of a commercial motor vehicle must be qualified as a brake inspector as outlined in the U.S. Department of Transportation (DOT) Federal Motor Carrier Safety Administration (FMCSA) guidelines listed under section 49 CFR §396.25. For complete information on brake inspector qualifications required to meet federal standards, visit [fmcsa.dot.gov](http://fmcsa.dot.gov).*

### Important Information About Meritor Automatic Slack Adjusters

Meritor automatic slack adjusters should not need to be manually adjusted in service to correct excessive push rod stroke. Excessive stroke may be an indication that a problem exists with the foundation brake, slack adjuster, brake actuator or other system components. Meritor recommends troubleshooting the problem, replacing suspect components, and then confirming proper brake operation prior to returning the vehicle into service.

In the event that a manual adjustment must be made (although not a common practice), schedule a service appointment as soon as possible to perform a full foundation brake, automatic slack adjuster, and other system component inspection to ensure the integrity of the overall brake system.

# Inspection

## Wheels On the Vehicle

**NOTE:** Perform these procedures in addition to those included in the Wheels Off the Vehicle inspection that follows. If all of the inspection criteria is not met, correct all issues before returning the vehicle to service.

### Brake Free Stroke

If measured free stroke is greater than 5/8-inch, or if free stroke is not available, find the causes and determine if further repairs are required.

### Brake Chamber Applied Stroke

1. Determine the chamber size (20, 24, 30, etc.) and the chamber type — either standard or long-stroke. Determine the brake adjustment limit in inches for that particular chamber size and type.
2. With the brakes released, verify each brake shoe, slack adjuster and chamber push rod returns to the “at rest” position.
3. Compute the chamber stroke dimension and verify it complies with Commercial Vehicle Safety Alliance (CVSA) guidelines. If you find one of the following conditions, inspect the brake to determine the cause.
  - A. Measured push rod stroke is at — or greater than — the maximum adjustment limit for the chamber size and type.
  - B. You can see the red- or orange-colored band on the push rod (excessive stroke indicator) when the brake is fully-applied.

### Brake Chamber

1. Check the brake chamber for damage or looseness. Ensure the retaining nuts are tightened to specification. Check the clevis retaining nut for the correct torque, if equipped.
2. Verify the chamber size (20, 24, 30, etc.) and the chamber type — either standard or long-stroke — are the same on each side of an axle.
3. Verify the push rod is exiting the chamber at a 90 degree angle, and it returns completely after each brake application.
4. Verify the caging bolt, nut and washer are installed, and the caging bolt cover is secure.

### Clevis and Clevis Pins

1. Check clevis pins for excessive wear and damage.

2. Verify clevis pin lockwires/pins are installed, and the clevis pins rotate in the automatic slack adjuster and clevis.

### Automatic Slack Adjuster

1. Inspect the automatic slack adjuster and adjustment brackets (if equipped) for wear or damage. Check the boot (if equipped) for tears or cuts.
2. Verify the retaining bolt or snap ring is correctly secured in the camshaft. Verify the automatic slack adjuster size (5”, 5.5”, 6”, etc.) is the same on each side of an axle.
3. Clean the lubrication fitting (if equipped). Lubricate the slack adjuster according to the manufacturer’s instructions.

### Brake Chamber Bracket

1. Inspect the chamber bracket for cracks and damage.
2. Verify the support brackets (if equipped) are secure and not damaged. Verify the bracket retaining bolts are tightened to specification.
3. Clean the lubrication fitting (if equipped). Lubricate the camshaft tube, camshaft and camshaft bushings according to the manufacturer’s instructions. Verify lubricant does not purge from the cam head end of the camshaft.

### Brake Linings

1. Wheel ends on the same axle must have the same linings and drums. Lining wear on both the top and bottom brake shoes should be the same dimension.
2. Measure lining wear. Linings must have a greater than 1/4-inch thickness at the center of the brake lining. Inspect linings for cracks, separation from the brake shoe table, and loose rivets. If you find any of these conditions, determine if brake shoe replacement is required.
3. Verify the linings are not contaminated with grease or oil. If you find either of these conditions during inspection, perform brake system diagnostics.
4. Inspect the brake linings to ensure the brakes will have enough available lining life to operate safely until the next scheduled maintenance and service interval.
5. Inspect the dust shields (if equipped) for looseness, cracks or other damage.

### Brake Drums

Inspect the brake drum for heavy grooving and cracks that extend to the end of the brake drum edge. Brake drums on the same axle should show similar wear conditions and thickness dimensions.

## Brake Shoes and Hardware

1. Inspect the rollers, roller retainers, retainer springs and return springs. Verify they are in the correct position, and not worn or damaged.
2. Inspect the brake shoes for wear at the anchor pin holes or roller slots. Inspect the anchor pins for wear and correct alignment.
3. Inspect the brake shoes for excessive corrosion where the lining blocks attach to the shoe table. Inspect for wear, bent areas or cracks in the shoes.

## Brake Spiders

1. Verify the brake spider retaining bolts are secure and not loose.
2. Verify the spider is not cracked or damaged.

## Wheels Off the Vehicle

**NOTE:** Perform these procedures in addition to those included in the Wheels On the Vehicle inspection in the previous section. If all of the inspection criteria is not met, correct all issues before returning the vehicle to service.

## Brake Drum

1. Closely inspect wear patterns on the friction surface inside the drum. Inspect for grooving, scoring, bluing and heat checks on the drum surface. If you find any of these conditions, determine if the drum requires replacement.
2. Inspect the mounting flange and drum pilot for excessive wear and cracks.
3. Use a brake drum diameter gauge to check if the drum is out-of-round, worn or damaged.

**NOTE:** A brake drum can be out-of-round but still within the correct inside diameter specification. The inside diameter of a drum can be worn out-of-specification, but the drum still be concentric (not out-of-round).

4. Inspect the brake drum surface conditions and inside diameter. Check for drum out-of-round. All of these factors must be within specification to operate the vehicle and meet the next scheduled maintenance and service interval.

## Brake Linings, Shoes, Hardware and Spiders

**NOTE:** To perform a closer inspection of the lining, shoe, hardware and spider, remove the brake shoes.

1. Verify the brake spider retaining bolts are secure and not loose. Inspect the spider for cracks or damage.

2. Wheel ends on the same axle must have the same linings and drums. Lining wear on both the top and bottom brake shoes should be the same dimension.
3. Measure lining wear. Linings must have a greater than 1/4-inch thickness at the center of the brake lining. Inspect linings for cracks, separation from the brake shoe table and loose rivets. If you find any of these conditions, determine if brake shoe replacement is required.
4. Verify the linings are not contaminated with grease or oil. Inspect for signs of excessive heat that occurred during operation, such as the lining material is flaking or cracked, or fibers have separated from the lining material. If you find any of these conditions during inspection, perform brake system diagnostics.
5. Inspect the brake linings to ensure the brakes will have enough available lining life to operate safely until the next scheduled maintenance interval.
6. Inspect the rollers, roller retainers, retainer springs and return spring. Verify they are in the correct position and not worn or damaged.
7. Inspect camshafts and camshaft bushings for wear.
8. Inspect brake shoes for wear at the anchor pin holes or roller slots. Inspect the anchor pins for wear. Verify anchor pins are aligned correctly.
9. Inspect the brake shoes for excessive corrosion where the lining blocks attach to the shoe table. Inspect for wear, bent areas or cracks.

## Before You Return the Vehicle to Service

1. Always replace both the same type of brake drums on an axle to maintain correct brake balance.
2. Consider replacement brake drums for the vehicle duty cycle. An aggressive and harsh duty cycle requires a heavier (higher mass) drum to manage heat energy created during braking. Also note that drums and linings on a front axle can be different from drums and linings on a rear axle due to the size of the brakes between the front steer and rear drive axles.
3. Use the lining material specified by the vehicle manufacturer to help ensure brakes perform correctly and meet Department of Transportation (DOT) regulations.
4. Always reline both wheels of a single axle at the same time. Always install the same type of linings and drums on both wheels of a single axle.

5. Always reline all four wheels of a tandem axle at the same time. Always install the same type of linings and drums on all four wheels of a tandem axle. It is not necessary for the front axle brakes to be the same as the rear drive axle brakes.
  6. Check the complete air system for worn hoses and connectors. With the air pressure at 100 psi (689 kPa), the brakes released and the engine off, tractor air pressure loss must not exceed two psi (13.8 kPa) per minute. Total tractor and trailer loss must not exceed three psi (20.7 kPa) per minute.
  7. Verify the air compressor drive belt, if equipped, is secure. Air system pressure must rise from compressor cut-in to approximately 100 psi (689 kPa) in two minutes.
  8. Inspect the governor to ensure it is set to the vehicle manufacturer's specifications. Verify both the tractor and trailer air systems are within the vehicle manufacturer's specifications.
  9. Always follow the vehicle manufacturer's specifications for brake friction material. Friction material requirements may not be the same for each vehicle.
  10. Verify the return springs retract the shoes completely when the brakes are released. Verify the spring brake retracts completely when it is released. Replace the return springs each time the brakes are relined.
  11. The air chamber area multiplied by the length of the automatic slack adjuster is called the AL factor. This number must be equal for both ends of a single axle and all four ends of a tandem axle.
  12. Before returning the vehicle to service, perform a road test to burnish new brake linings (if required). Then inspect brake components and perform a final brake adjustment.
4. Immediately check the temperature of each brake drum after burnishing to ensure that braking effort was sufficient on each wheel. A drum temperature that is greater than those stated below can be a possible indication of brake imbalance. **Note:** A drum that is approximately 50°F degrees (10°C) cooler side-to-side, or one that is 100°F (38°C) cooler front-to-rear than any of the others, can indicate insufficient braking effort on that wheel. To check for brake imbalance:
    - A. Verify the foundation cam brake system is correct. Refer to Meritor Maintenance Manual 4, and the manufacturer's instructions and specifications.
    - B. Verify the air system is correct. Refer to the manufacturer's instructions and specifications.
    - C. Repair brake imbalance, if found. Refer to Meritor Maintenance Manual 4, and the manufacturer's instructions and specifications.
    - D. Follow the procedure above to reburnish the brakes.
    - E. Allow the brakes to cool to ambient temperature.
    - F. Manually adjust all of the brakes. Refer to Meritor Maintenance Manual 4.

## Brake Burnishing Procedure

### WARNING

To prevent serious personal injury and damage to components, burnish the brakes in a safe area. After burnishing, immediately check the temperature of each drum to ensure braking effort was sufficient on each wheel, and that the brakes are not imbalanced. Repair brake imbalance, if found.

1. Manually adjust all of the brakes. Refer to Meritor Maintenance Manual 4.
2. While driving the vehicle in a safe area at 20 mph (32 km/h), apply the brakes at approximately 10 feet (3.05 m) per second until the vehicle decelerates to 5 mph (8 km/h) *without stopping the vehicle*. Repeat this procedure 10 times.
3. After 10 brake applications, decelerate from 20 to 0 mph (32 km/h– 0 km/h) and make *one complete stop*.

## How to Obtain Additional Maintenance, Service and Product Information

Meritor offers a wide variety of reference materials and tools to support the inspection procedures in this bulletin. Publications contain safety, inspection and repair procedures for foundation cam brakes.

- Literature on Demand ([www.meritor.com/customer/northamerica/lod](http://www.meritor.com/customer/northamerica/lod))
- The BullPen ([www.meritorbullpen.com](http://www.meritorbullpen.com))
- Meritor Mobile ([www.meritor.com/meritormobile](http://www.meritor.com/meritormobile))
- Your DriveForce™ Team Member ([www.meritor.com/customer/northamerica/driveforce](http://www.meritor.com/customer/northamerica/driveforce))

## Publications Specific to This Bulletin

### Meritor

Visit the Literature on Demand section of [meritor.com](http://meritor.com) to obtain the following publications that support inspection procedures in this bulletin.

- Maintenance Manual 1: Preventive Maintenance and Lubrication
- Maintenance Manual 4, Cam Brakes and Automatic Slack Adjusters
- Maintenance Manual MM-99100: Wheel Equipment/Disc Wheel Hubs and Brake Drum Failure Analysis

## Meritor WABCO

Visit Meritor WABCO's website at [www.meritorwabco.com](http://www.meritorwabco.com) to obtain publications that support inspection procedures in this bulletin for the following Meritor WABCO products.

- Pneumatic ABS for tractors and trailers
- Air compressors
- Air dryers
- Air brake control valves



**Meritor Heavy Vehicle Systems, LLC**  
2135 West Maple Road  
Troy, MI 48084 USA  
866-OnTrac1 (668-7221)  
[meritor.com](http://meritor.com)

Information contained in this publication was in effect at the time the publication was approved for printing and is subject to change without notice or liability. Meritor Heavy Vehicle Systems, LLC, reserves the right to revise the information presented or to discontinue the production of parts described at any time.

Copyright 2013  
Meritor, Inc.  
All Rights Reserved

Printed in USA

TP-1363  
Revised 07-13  
(16579)

# GENUINE MERITOR® BRAKE HARDWARE KITS



 **IDEAS DRIVING RESULTS**  
GENUINE REPLACEMENT PRODUCT  
FOR GENUINE PERFORMANCE.



# GENUINE MERITOR BRAKE HARDWARE KITS

## MERITOR ADVANTAGES

- Delivers both proven stopping performance and extended brake life to reduce maintenance costs
- All parts tested by Meritor to genuine Meritor product specifications
- All parts engineered to manage the brake forces generated for superior performance
- Built-in technology leadership you expect from a global leader in brake manufacturing
- Proven quality control
- Expert technical support available online 24/7
- All components for genuine Meritor brake kits are sourced only from North America
- Online technical library
- Order entry/tracking available using XpresswayPlus.com
- Competitively priced to meet your needs
- Meritor aftermarket warranty

Genuine Meritor Brake Hardware Kits – an idea that helps you drive results with the exact quality, support and pricing you need to pull ahead of your competition and stay ahead!

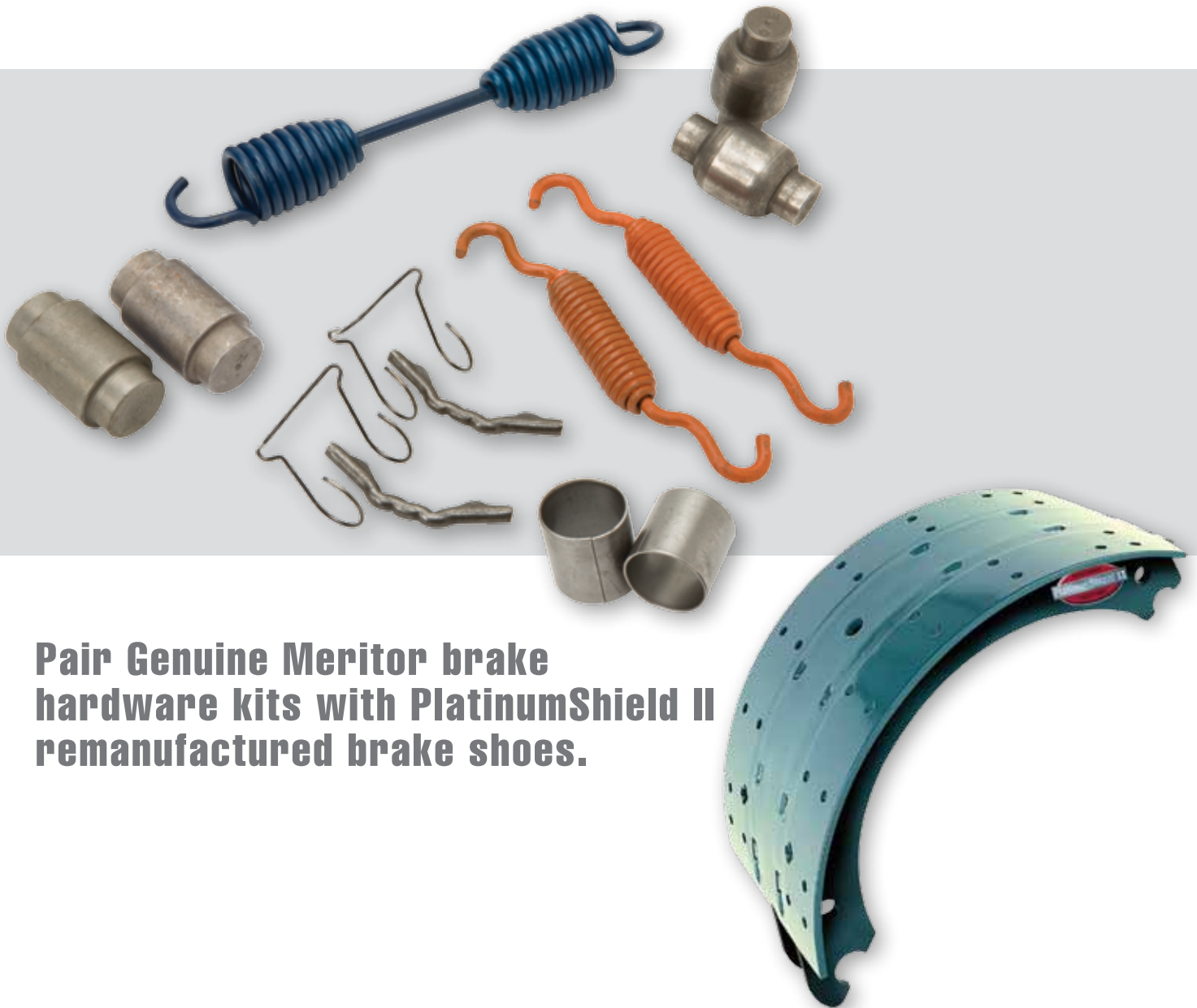

**Pair Genuine Meritor brake hardware kits with PlatinumShield II remanufactured brake shoes.**

Genuine Meritor brake hardware kits feature the exact same hardware used on brake assemblies installed in new trucks.

### Anchor Pins

Designed to fit securely into the bushing, Meritor anchor pins are case-hardened to provide longer life and consistent performance. And, they are manufactured to a close fit between pin and shoe, while allowing the shoe to move freely. Quality material and heat treatment are essential for endurance.



### Brake Shoe Rollers

Meritor "Rolls-Rite" brake shoe rollers feature smooth radius edges to prevent flatspotting. When uneven brake cam pressure occurs, pressure is distributed evenly across the radius-edge surface of the roller to prevent cracks that lead to flat spots on the roller surface. Shoe rollers are also thru-hardened and roller ends are machined smooth for longer life.



### Stainless Steel Anchor Pin Bushings

Made of high-grade stainless steel, these anchor pin bushings will not corrode, preventing the anchor pins from freezing into the spider. This facilitates easier anchor pin removal.



### Brake Return Springs

Made to exacting standards using high-grade spring steel wire and shot peened to toughen the metal. Shot peening removes surface flaws and forming marks, which is critically important because, under stress, any surface flaws or forming marks become the weakest part of the spring. High-grade wire retains high spring tension for greater durability.



### Wire Roller Retainer

Coated to guard against corrosion which can cause the brake shoe rollers to bind in the brake shoe and accelerate wear on the camshaft.

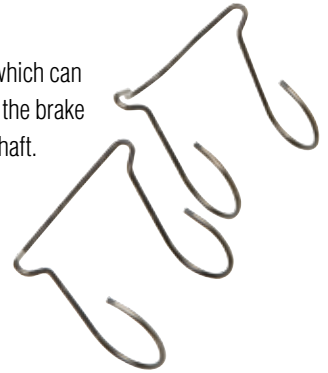

## A BETTER IDEA IN REPLACEMENT HARDWARE

Genuine Meritor brake hardware kits deliver a better idea when replacement time comes around. There is a wide variation of quality in commercial brake hardware replacement kits. Ranging from the original equipment product to remanufactured replacement parts to "knock-off" parts manufactured offshore.

As a global leader in braking, Meritor offers genuine OEM replacement product. That's an idea that drives better results for you.





## IDEAS DRIVING RESULTS

As a world leader in providing aftermarket solutions for the global commercial vehicle and industrial markets, Meritor is committed to providing our customers with innovative aftermarket ideas that deliver the results you need to get the job done faster, better and more efficiently.



**Meritor Heavy Vehicle Systems, LLC**  
7975 Dixie Highway  
Florence, Kentucky 41042 USA

**For more information:**

**U.S. 888-725-9355**

**Canada 800-387-3889**

**[XpresswayPlus.com](http://XpresswayPlus.com)**

**[meritor.com](http://meritor.com)**

Litho in USA Revised 05-12  
SP-0773 (47865/11900)  
©2012 Meritor, Inc.

Vehicle models, brands and names depicted herein are the property of their respective owners, and are not in any way associated with Meritor, Inc., or its affiliates.