



INSTALLATION MANUAL
MATRIX FRONT BUMPER
PRODUCT NUMBER: X435X
APPLICATION: 2017+ FORD RAPTOR



IMPORTANT SAFETY GUIDE | Your safety and the safety of others is very important.

In order to help you make informed decisions about safety, we have provided the following warnings, safety precautions, installation instructions, and other important information to alert you to potential hazards that could hurt you or others.

Please do a job safety analysis before each task to identify potential hazards for your situation and remove/protect against them. Use own good judgment and take your time.

Check packaged materials immediately upon arrival to ensure that all listed parts are included and undamaged.

Read and understand all warnings, safety precautions, and instructions before installing this product.

SENSORS FIELD OF VIEW MAY BE ALTERED WITH USE OF THE REPLACEMENT BUMPER.

WARNINGS

- Failure to observe the following warnings and instructions provided in this manual could lead to severe injury and/or death.
- For professional installation only. Careless installation and/or operation can result in serious injury, death, and/or equipment damage. All liability for installation and use rests with the user or consumer.
- Fab Fours, Inc. only approves installing this product according to these written instructions with the hardware provided. Failure to install according to these instructions will invalidate the warranty. This includes, but is not limited to, using alternative installation methods, hardware, or materials.
- This product is for off road use only.

SAFETY PRECAUTIONS

- Always remove jewelry and wear eye protection.
- Always use extreme caution when jacking up a vehicle for work. Set emergency brake and use tire blocks. Locate and use the vehicle manufacturers designated lifting points. Use jack stands.
- Always use appropriate and adequate care in lifting components into place.
- Always ensure components will remain secure during installation and operation.
- Always wear safety glasses when installing this kit. A drilling operation will cause flying metal chips. Flying chips can cause serious eye injury.
- Always use extreme caution when drilling a vehicle. Always disconnect power before welding. Thoroughly inspect the area to be drilled (on both sides of material when possible) prior to drilling, and relocate any objects that may be damaged.
- Always use extreme caution when welding a vehicle. Thoroughly inspect the area to be welded (on both sides of material when possible) prior to welding, and relocate any objects that may be a fire hazard. When welding in a cab, make sure the interior surfaces are covered (e.g., welding blanket) and a fire extinguisher is at hand.
- Always use extreme caution when cutting and trimming during fitting.
- Always tighten all nuts and bolts securely per installation instructions.
- Always route electrical cables carefully. Avoid moving parts, components that become hot, and rough or sharp edges.
- Always insulate and protect all exposed wiring and electrical terminals.
- Perform regular inspections and maintenance on mounts and hardware.

TABLE OF CONTENTS

- 2 SAFETY / DISCLAIMER
- 3 TABLE OF CONTENTS
- 4 A MESSAGE FROM THE OWNER
- 5 GETTING STARTED
- 6 PROVIDED MATERIAL
- 7 DISASSEMBLY
- 13 INSTALLATION

A MESSAGE FROM THE OWNER



Fab Fours' was born out of a passion for customizing vehicles and a love of the outdoors. Our engineering team uses the latest 3D design software to turn new product ideas into reality. In our factory, designs come to life with the combination of cutting edge technology for metal cutting and forming and an American workforce that puts its' heart and pride into every product.

From design and manufacturing, to quality and delivery, Fab Fours' mission is to be the market leader for steel truck and jeep accessories. We make sure a quality product is delivered on time, more than expected, better than expected to our customers.

Enjoy your new Fab Fours product. Welcome to the family!

Greg Higgs

FOUNDER, FAB FOURS

GETTING STARTED

Before you begin the installation process of your new Fab Fours product, we suggest laying out all materials and parts on a pad or protective surface.

Failure to fully account for all components before beginning installation may leave vehicle immobile until part is acquired. Refer to the next pages as an inventory check.

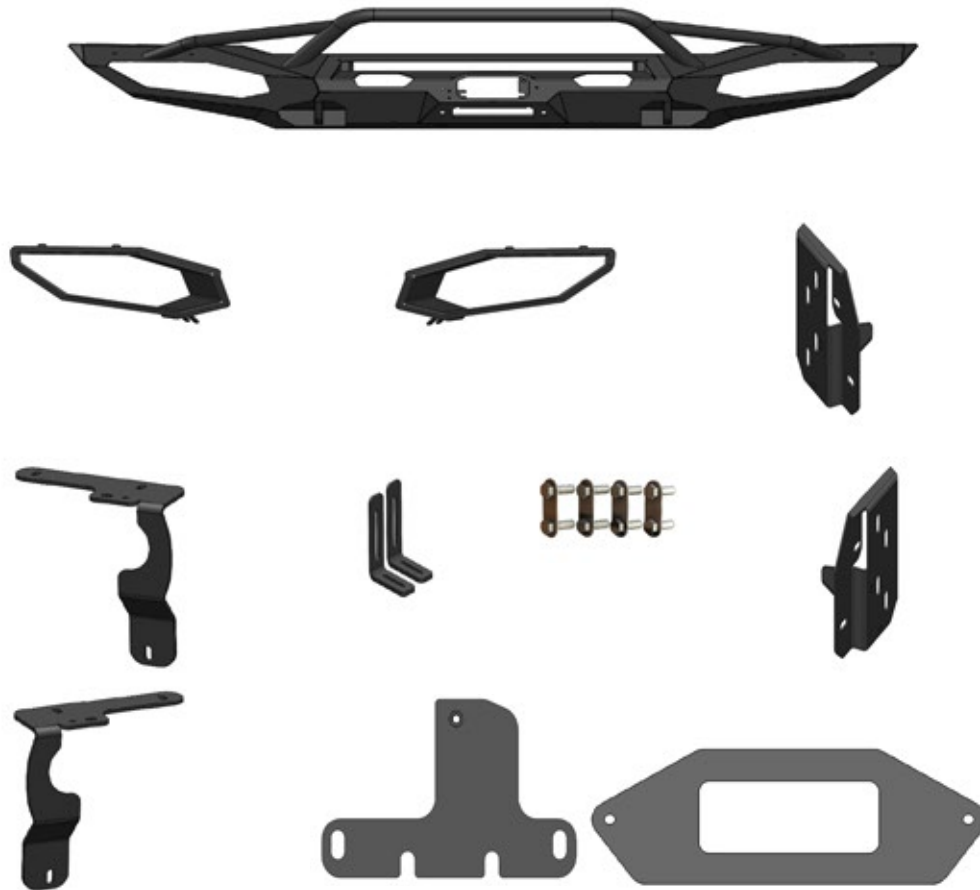

PROVIDED MATERIALS



X435X-IM



50254-HW

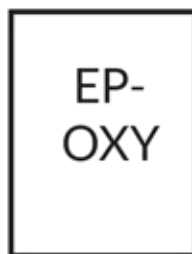

61632 x2



HARDWARE KIT | 50254

| FAB FOURS IDENTIFICATION | COMPONENT DESCRIPTION | QTY |
|--------------------------|---|-----|
| 50254-HW | ½"-13 x 1.25", Yellow Zinc Hex Bolt, Grade 8 | 8 |
| 50254-HW | ½"-13, Yellow Zinc Hex Nut, Grade 8 | 12 |
| 50254-HW | 1/2", Yellow Zinc Flat Washer, Grade 8 | 20 |
| 50254-HW | 1/2", Yellow Zinc Lock Washer, Grade 8 | 16 |
| 50254-HW | 5/16"-18 x 1.00", Yellow Zinc Hex Bolt, Grade 8 | 2 |
| 50254-HW | 5/16", Stainless Steel, Fender Washer | 2 |
| 50254-HW | 5/16", Yellow Zinc Lock Washer, Grade 8 | 2 |
| 50254-HW | ¾"-20 x 1", Yellow Zinc Hex Cap Bolt, Grade 8 | 8 |
| 50254-HW | 1/4", Yellow Zinc Flat Washer, Grade 8 | 16 |
| 50254-HW | 1/4", Yellow Zinc Lock Washer, Grade 8 | 8 |
| 50254-HW | 1/4", Yellow Zinc Hex Nut, Grade 8 | 8 |
| 50254-HW | 1/4"-20 x 1.25" SS Button Head Bolt | 4 |
| 50254-HW | 1/4" SS Nylock Hex Nut | 4 |
| 50254-HW | 1/4" SS Flat Washer | 4 |
| 50254-HW | 1/4" SS Flat Washer | 8 |

TOOLS REQUIRED

- 3/4" Socket wrench
- 1/2" Socket wrench
- 7/16" Socket wrench
- 21mm socket wrench
- 15mm socket wrench
- 10mm Socket wrench
- 8mm Socket wrench
- 13mm Socket wrench
- 5/32" Allen wrench
- E6 Torx socket
- Pry tool
- Cutting tool

ASSISTANCE

We recommend two people perform the installation as items are heavy and may need to be held in place while installing.

ORGANIZATION

Disassemble the vehicle where you can catalog and store everything. We suggest labeling and bagging all the OEM bolts when removing from the vehicle. Failure to keep track of parts could lead to an inability to properly reinstall components.

NOTE: Save all OEM parts until installation is complete!

1. From underneath the front of the truck remove the six (6) fasteners attaching the OEM skid plate to the truck with a 13mm and 15mm socket. And set aside for later install. (Figure 1 & 2)

2. Using a body pry tool, carefully remove center plastic piece, indicated in Figure 3 in the center of the OE bumper. (Figure 3 & 4)



Figure 1



Figure 2



Figure 3



Figure 4

3. If Truck is ACC equipped: Unplug and remove the Adaptive Cruise Control sensor from the OE bumper using a E6 torx socket. (Figure 5)



Figure 5

4. Note the type of Adaptive Cruise Control (ACC) sensor you have. Figure 6 shows a large ACC sensor and figure 7 shows a smaller sensor. (Figure 6 & 7)



Figure 6

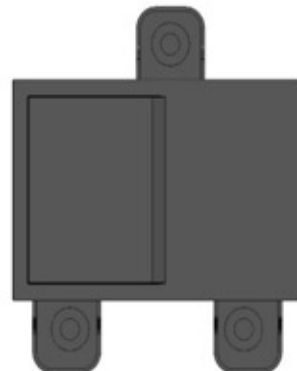

Figure 7

5. Use a 21mm socket to remove the three nuts per side of OEM bumper. Two are located under the plastic center piece (Figure 8) and the third is accessible from the back of the frame. (Figure 9)



Figure 8

6. Use an 8mm socket wrench to remove the two bolts (one per side) that hold on the bumper side support bars from the truck side leaving the support bars attached to the bumper.

7. Carefully pull away the bumper and remove the rubber shroud connectors along the top.



Figure 9

8. Pull the rubber covers off the tow hooks and use a 15mm socket wrench to remove the tow hooks from the truck. (Figure 10)



Figure 10

9. To remove the louver system (located between the frame horns) the grill must be removed. Use a body pry tool to remove the 12x push plugs holding the grill cover on. Remove grill cover from the truck. (Figure 11)



Figure 11

10. Use a 10mm socket wrench to remove the 4x bolts located at the top of the grill. (Figure 12)



Figure 12

11. Carefully pull the valence piece beside the grill away from the grill and head light to access the 10mm bolt at the base of the grill. Use a 10mm socket to remove this bolt on each side. (Figure 13)



Figure 13

12. Carefully remove the grill from the truck by pulling along the sides to disengage the grill clips.

13. Use an 8mm socket wrench to remove the 4x bolts holding the louver system to the frame horns. Unplug and remove the system from the truck. (Figure 14)



Figure 14

14. Remove the front air skirt from the louver system by unclipping it from the assembly. (Figure 15)



Figure 15

15. Trim the louver system as shown.
(Figure 16)



Figure 16

INSTALLATION

16. Re-attach the louvers to the truck using the provided brackets (21614 and 21615) along with the OEM bolts and (6) 1/4" yellow zinc hex bolt, flat washer, lock washers and nuts (50254-HW). (Figure 17 & 18)



Figure 17



Figure 18

17. Install the mounting brackets (22347 and 22348) into the frame rails. Prior to attachment to frame rails, install the provided (4) 1/2" bolt strips (20296) into the slots facing out toward the bumper. Attach brackets using a 3/4" socket and wrench with the provided (8) 1/2" yellow zinc hex bolts, flat washers, lock washers and nuts (50254-HW). (Figure 19)



Figure 19

18. If installing a 30" Single row light bar: Do so now using the provided L-brackets (21871) along with (2) 1/4" yellow zinc hex bolts, flats/lock washers and nuts to attach the light bar to the mounting structure (50254-HW). (Figure 20)

19. Using a sharpie, mark out a 2.5"x5" rectangle on the back of the plastic cover removed during step 2. Cut the rectangle out using preferred cutting tool. (Figure 21)



Figure 21

20. Use the provided epoxy packs to epoxy the rectangle cut out in step 19 to the back of the sensor cover plate (22350). NOTE: It is advised to install the sensor cover plate on the bumper prior to epoxy to mark out the edges of the bumper cut out with sharpie. Be careful not to place the rectangle piece outside of the sharpie marks to avoid interference. (Figure 22)



Figure 22

21. If utilizing the large ACC sensor, you will mount it directly into the bumper using the provided (2) M8 nylock nuts and weld nut along with a 13mm and E6 torx wrench (50254-HW). (Figure 23)



Figure 23

22. If utilizing the small ACC sensor you will install by attaching the sensor to the provided plate (22339) using the provided (2) 8M nylock nuts and weld nut along with a 13mm and E6 torx wrench (50254-HW). (Figure 24)

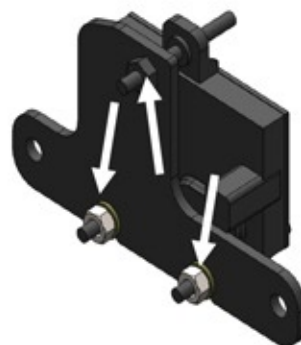

Figure 24

23. Use the provided (2) 1/4" stainless steel button head bolts, flat washers, flat washer and nuts to install the small sensor and sensor into the bumper (50254-HW). (Figure 25)

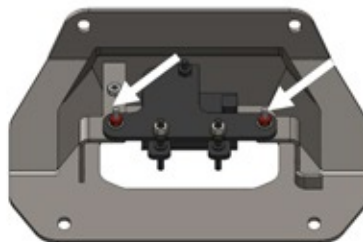

Figure 25

24. Install the sensor cover plate from step 20 onto the bumper using the provided (2) 1/4" stainless steel button head bolts, flat washers, flat washers and nuts with a 5/32" Allen wrench and 7/16" socket wrench (50254-HW). (Figure 26)



Figure 26

25. Install the light boxes (22345 and 22346) into the bumper by placing the upper tabs into the bracket slots. Use the provided (2) 5/16" hex head bolts with fender washers and lock washers with a 1/2" socket wrench to attach the boxes to the Bumper (50254-HW). (Figure 27)

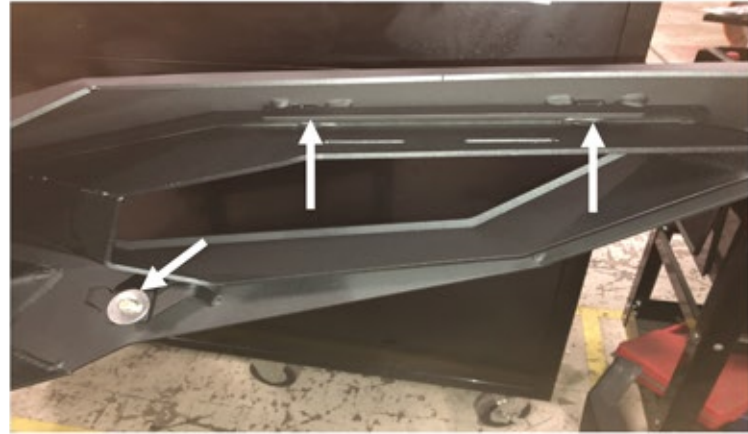

Figure 27

26. With assistance, hold the bumper up to the mounting brackets and use the provided (8) 1/2" hex nuts and flat/lock washers along with a 3/4" socket wrench (50254-HW). Hold the bumper to the desired location and tighten all mounting hardware. (Figure 28)

Figure 28

27. Reinstall the skid plate removed during step 1 by reversing the steps.

28. Reinstall the grill by reversing the steps 9-12.