



INSTALLATION MANUAL
MATRIX FRONT BUMPER
PRODUCT NUMBER: FS11-X255X
APPLICATION: 2011-16 FORD SUPER DUTY



IMPORTANT SAFETY GUIDE | Your safety and the safety of others is very important.

In order to help you make informed decisions about safety, we have provided the following warnings, safety precautions, installation instructions, and other important information to alert you to potential hazards that could hurt you or others.

Please do a job safety analysis before each task to identify potential hazards for your situation and remove/protect against them. Use own good judgment and take your time.

Check packaged materials immediately upon arrival to ensure that all listed parts are included and undamaged.

Read and understand all warnings, safety precautions, and instructions before installing this product.

SENSORS FIELD OF VIEW WILL BE ALTERED WITH USE OF THE REPLACEMENT BUMPER.

WARNINGS

- Failure to observe the following warnings and instructions provided in this manual could lead to severe injury and/or death.
- For professional installation only. Careless installation and/or operation can result in serious injury, death, and/or equipment damage. All liability for installation and use rests with the user or consumer.
- Fab Fours, Inc. only approves installing this product according to these written instructions with the hardware provided. Failure to install according to these instructions will invalidate the warranty. This includes, but is not limited to, using alternative installation methods, hardware, or materials.
- This product is for off road use only.

SAFETY PRECAUTIONS

- Always remove jewelry and wear eye protection.
- Always use extreme caution when jacking up a vehicle for work. Set emergency brake and use tire blocks. Locate and use the vehicle manufacturers designated lifting points. Use jack stands.
- Always use appropriate and adequate care in lifting components into place.
- Always ensure components will remain secure during installation and operation.
- Always wear safety glasses when installing this kit. A drilling operation will cause flying metal chips. Flying chips can cause serious eye injury.
- Always use extreme caution when drilling a vehicle. Always disconnect power before welding. Thoroughly inspect the area to be drilled (on both sides of material when possible) prior to drilling, and relocate any objects that may be damaged.
- Always use extreme caution when welding a vehicle. Thoroughly inspect the area to be welded (on both sides of material when possible) prior to welding, and relocate any objects that may be a fire hazard. When welding in a cab, make sure the interior surfaces are covered (e.g., welding blanket) and a fire extinguisher is at hand.
- Always use extreme caution when cutting and trimming during fitting.
- Always tighten all nuts and bolts securely per installation instructions.
- Always route electrical cables carefully. Avoid moving parts, components that become hot, and rough or sharp edges.
- Always insulate and protect all exposed wiring and electrical terminals.
- Perform regular inspections and maintenance on mounts and hardware.

TABLE OF CONTENTS

2	SAFETY / DISCLAIMER
3	TABLE OF CONTENTS
4	A MESSAGE FROM THE OWNER
5	GETTING STARTED
6	PROVIDED MATERIAL
8	DISASSEMBLY
10	INSTALLATION

A MESSAGE FROM THE OWNER



Fab Fours' was born out of a passion for customizing vehicles and a love for the outdoors. Our engineering team uses the latest 3D design software to turn new product ideas into reality. In our factory, designs come to life with the combination of cutting edge technology for metal cutting and forming and an American workforce that puts its' heart and pride into every product.

From design and manufacturing, to quality and delivery, Fab Fours' mission is to be the market leader for steel truck and jeep accessories. We make sure a quality product is delivered on time, more than expected, better than expected to our customers.

Enjoy your new Fab Fours product. Welcome to the family!

Greg Higgs

FOUNDER, FAB FOURS

GETTING STARTED

Before you begin the installation process of your new Fab Fours product, we suggest laying out all materials and parts on a pad or protective surface.

Failure to fully account for all components before beginning installation may leave vehicle immobile until part is acquired. Refer to the next pages as an inventory check.

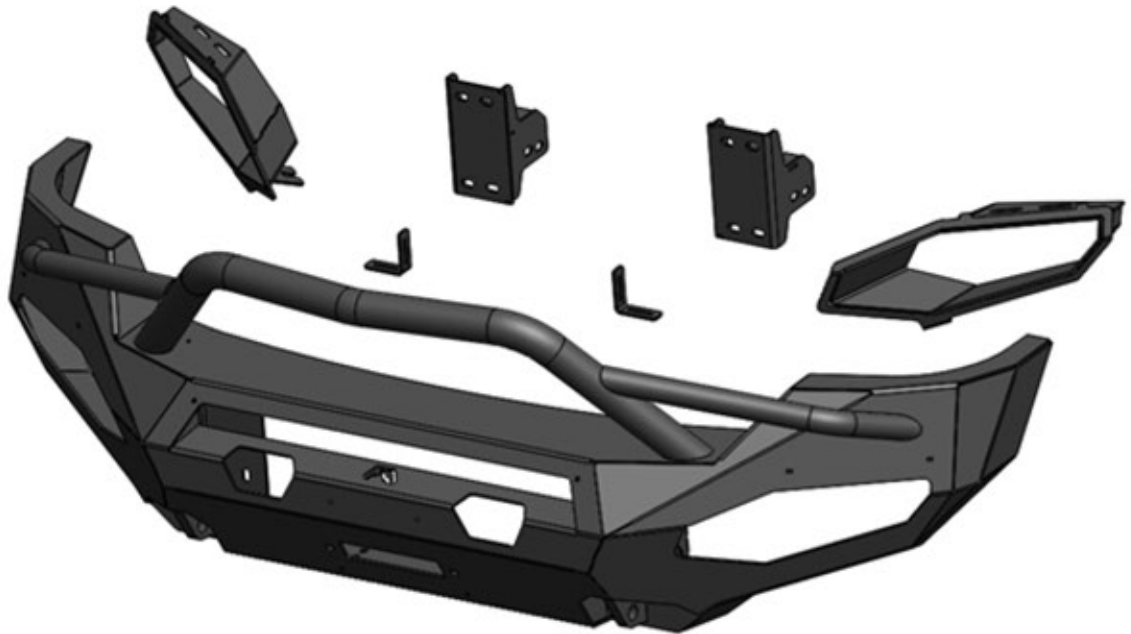

PROVIDED MATERIALS

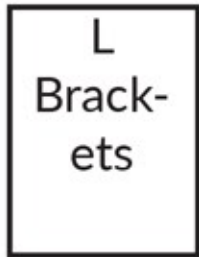

21871 x2



50242-HW



X255X-IM



20296 x4



22306



22307



22308



22310



22311

HARDWARE KIT | 50242

FAB FOURS IDENTIFICATION	COMPONENT DESCRIPTION	QTY
50242-HW	1/4"-20, Yellow Zinc Hex Cap Bolt, Grade 8	2
50242-HW	1/4"-20, Yellow Zinc Hex Nut, Grade 8	2
50242-HW	1/4", Yellow Zinc Flat Washer, Grade 8	4
50242-HW	1/4", Yellow Zinc Lock Washer, Grade 8	2
50242-HW	5/16"-18, Yellow Zinc Hex Cap Bolt, Grade 8	2
50242-HW	5/16", Stainless Steel Flat Washer	2
50242-HW	5/16", Yellow Zinc Lock Washer, Grade 8	2
50242-HW	M12 Hex Nut	6
50242-HW	M12 Split Lock Washer	6
50242-HW	M12 Flat Washer	6
50242-HW	1/2"-13 Hex Nut, Grade 8	8
50242-HW	1/2" Lock Washer, Grade 8	8
50242-HW	1/2" Flat Washer, Grade 8	8

TOOLS REQUIRED

- Socket wrench w/ extension
- 15mm socket wrench
- 18mm socket wrench
- 1/2" socket wrench
- 13mm socket wrench
- 3/4" Open end wrench
- 7/16" Open end wrench
- 3/8" Open end wrench
- 7/32" Socket
- 7/16" Socket and open end wrench
- Phillips screwdriver

ASSISTANCE

We recommend two people perform the installation as items are heavy and may need to be held in place while installing.

ORGANIZATION

Disassemble the vehicle where you can catalog and store everything. We suggest labeling and bagging all the OEM bolts when removing from the vehicle. Failure to keep track of parts could lead to an inability to properly reinstall components.

DISASSEMBLY

Note: Save all OEM parts until installation is complete!

- 1. Disconnect factory fog lamp harness from the connector on the lower radiator core support.**
- 2. Unclip the splash mat from the factory bumper and fold up out of the way.**
- 3. Remove bumper support bracket screws from the body mount bracket behind the bumper with a 13mm wrench or socket.**
- 4. While supporting the bumper, unscrew the main bumper mounting bolts from the front face of the bumper. The bolts will remain captive in the bumper. (Figure 1)**



Figure 1

5. Remove OEM bumper assembly and set aside.

6. If equipped, remove the under-run guards from both frame rails with an 18mm Socket. Save this hardware for later use. (Figure 2)

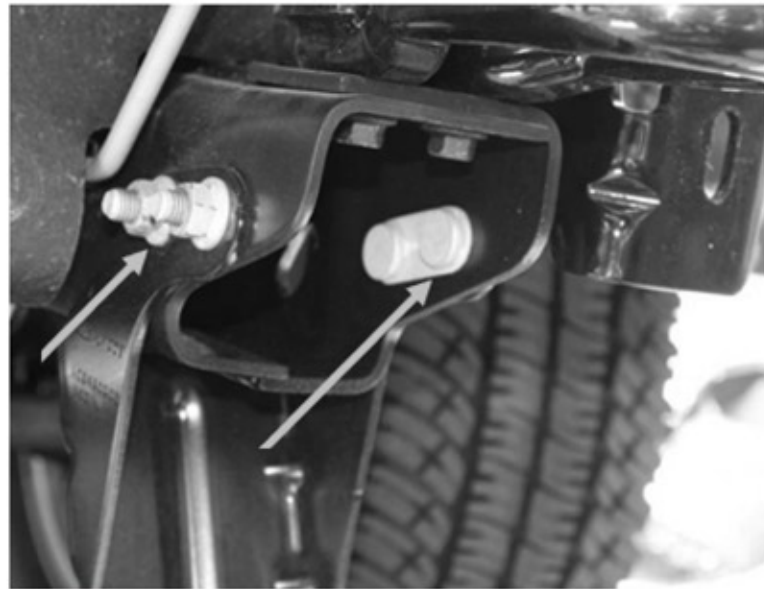

Figure 2

7. Remove the bumper mount / tow hook assembly from both frame rails using a 15mm socket. Save this hardware for later use. (Figure 3)



Figure 3

INSTALLATION

- **Optional:** If installing winch and roller fairlead into bumper, do it at this time. Follow the winch manufacturer's instructions for installation. If you are installing a winch with a pulling capacity of 12,000 lbs. or greater, the front face mounting holes must be used.

If not installing a winch, a license plate may be installed onto the front face of the bumper using the provided $\frac{1}{4}$ " hardware.

8. Install intermediate mount onto the frame rail using the OEM under-run guard stud plates and nuts, and tow hook bolts with 12mm nuts provided in the hardware kit. Be sure stud plates are re installed in the factory direction. If the truck was not equipped with under run guards from the factory, use the $\frac{1}{2}$ " fasteners provided in the hardware kit. **DO NOT FULLY TIGHTEN**, repeat for other side. (Figure 4)

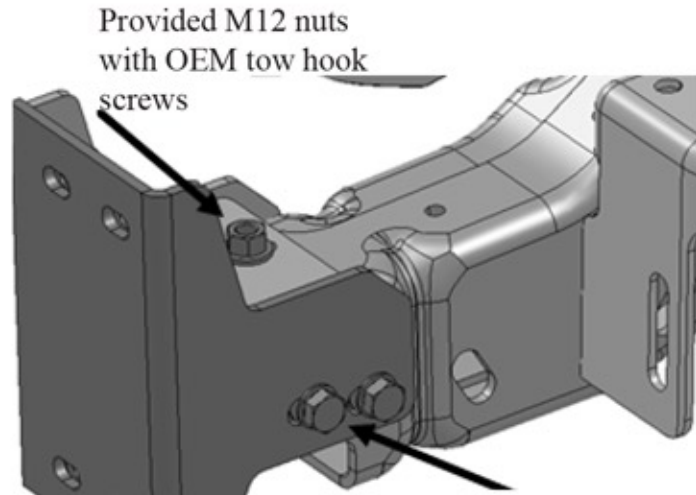

Figure 4

OEM stud plates or provided $\frac{1}{2}$ " hardware

9. If installing a 30" Light bar: Do so as this point using the provided 1/4" hardware along with the (2) L-brackets (21977)(50242-HW). (Figure 5)



Figure 5

10. Install the light boxes assembly (22307-22308) by inserting the upper tabs into the bumper bracket. Use the 5/16" Yellow Zinc Bolts with lock washers and Stainless steel fender washers to fasten it them to the bumper (50242-HW). (Figure 6)



Figure 6

11. Lift the bumper and carefully inert the studs into the slots on the mounting brackets. With the bumper supported, install four nuts, washers, and lock washers per side onto the studs. DO NOT FULLY TIGHTEN (Figure 7)

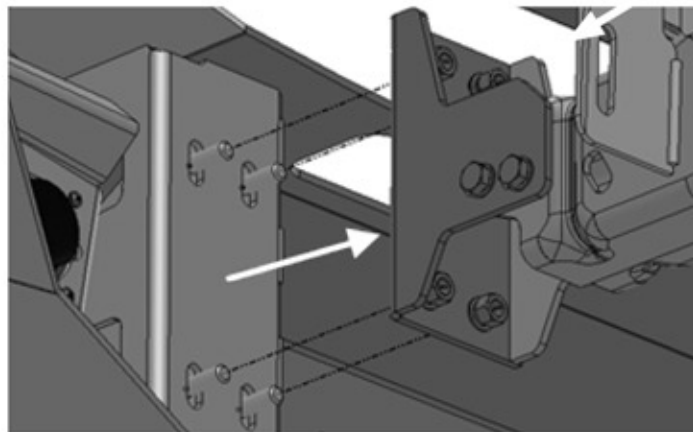

Figure 7

12. Adjust the bumper to achieve good visual alignment as follows:

- 1. Adjust in/out bumper alignment with mounting bracket to frame hardware.**
- 2. Adjust up/down and left/right alignment with bumper to mounting bracket hardware**

13. Tighten all fasteners fully; beginning with frame mounts. Then tighten all mount-to-bumper fasteners.