



## **INSTALLATION INSTRUCTIONS**



**2011-17 GM C/K2500HD & C/K3500HD  
4" ULTIMATE SYSTEM  
w/ UNIBALL UPPER CONTROL ARMS**

**FTS21129**



**- PARTS LIST -**

	<b>FTS21130</b>	<b>4" SYSTEM W/ PERFORMANCE SHOCKS</b>
1	FTS21129	4" SYSTEM W/O REAR BLOCKS
2	FTS7341	PERFORMANCE SHOCK
2	FTS7299	PERFORMANCE SHOCK

	<b>FTS21188</b>	<b>4" SYSTEM W/ STEALTH SHOCKS</b>
1	FTS21129	4" SYSTEM W/O REAR BLOCKS
2	FTS6019	STEALTH SHOCK
2	FTS6341	STEALTH SHOCK

	<b>FTS21202</b>	<b>4" SYSTEM W/ DIRT LOGIC SHOCKS</b>
1	FTS21129	4" SYSTEM W/O REAR BLOCKS
2	FTS810932	DIRT LOGIC 2.25 NON RESI BLACK FRONT
2	FTS810942	DIRT LOGIC 2.25 NON RESI BLACK REAR

	<b>FT20539</b>	<b>HARDWARE KIT</b>
1	FTLOCK	THREAD LOCKING COMPOUND 1 MIL
2	FTCLAMP	CLAMP 3/8X1/2W .26THK NEOPRENE
2	FTCLAMP10	ADEL CLAMP #10
4	25200751052	SCREW 1/4-20 X 3/4 HEX G5 Z1
4	FT84	GREASE FITTING 1/4-28

	<b>FT90121</b>	<b>HARDWARE KIT</b>
2	56180004152	9/16" -18 C-LOCK NUT
2	56000005052	9/16 SAE WASHER G5 ZINC
2	75160004152	3/4-16 C-LOCK NUT ZINC

	<b>FTS21129</b>	<b>4" SYSTEM W/O REAR BLOCKS</b>
1	FTS20503D	SPINDLE (DRIVER)
1	FTS20503P	SPINDLE (PASSENGER)
1	FT20575BK	UCA (DRIVER)
1	FT20576BK	UCA (PASSENGER)
2	FT20550	TORSION KEY
1	FT20539	HARDWARE KIT
1	FT20588	HARDWARE SUBASSEMBLY

	<b>FT20588</b>	<b>HARDWARE SUBASSEMBLY</b>
1	FT90111	BUSHING KIT
1	FTREGCARD	REGISTRATION CARD
4	FT147	MISALIGNMENT
2	FT20579	UNIBALL SPACER
2	FT94500	UNIBALL ADAPTER PIN
4	12008007100	8" Zip Tie
1	FT90121	HARDWARE KIT
1	FTREGCARD	REGISTRATION CARD
1	FTAS16	DRIVER WARNING DECAL
2	FT21129I	INSTRUCTIONS

	<b>FT90111</b>	<b>BUSHING KIT</b>
8	FT1038	BUSHING BLACK URETHANE
4	FT77	SLEEVE 1.000 X .630 X 2.620
1	FTLUBE	URETHANE LUBE 1 PACKET

**- TOOL LIST -**

**Required Tools (Not Included)**

- Basic Hand Tools
- Floor Jack
- Jack Stands
- Assorted Metric and S.A.E sockets, and Allen wrenches
- Torque Wrench
- Torsion Bar Removal Tool



## - PRE-INSTALLATION NOTES -

### ***Read this before you begin installation-***

Check all parts to the parts list above before beginning installation.

Read all instructions thoroughly from start to finish before beginning the installation. If these instructions are not properly followed severe frame, driveline and / or suspension damage may occur.

Check your local city and state laws prior to the installation of this system for legality. Do not install if not legal in your area.

Prior to the installation of this suspension system perform a front end alignment and record. Do not install this system if the vehicle alignment is not within factory specifications. Check for frame and suspension damage prior to installation.

The installation of this suspension system should be performed by two professional mechanics.

Use the provided thread locking compound on all hardware.

Do not combine this suspension system with any other lift device or parts.

This suspension must be installed with Fabtech shock absorbers.

**WARNING-** Installation of this system will alter the center of gravity of the vehicle and may increase roll over as compared to stock.

Cannot use OEM wheel and tire.

Will not fit standard cab models.

Requires cutting of fenderwell sheet metal for use with 35" tires.

Vehicles that receive oversized tires should check ball joints, uniballs, tie rods ends, pitman arm and idler arm every 2500-5000 miles for wear and replace as needed.

Verify differential fluid is at manufactures recommended level prior to kit installation. Installation of the kit will reposition the differential and the fill plug hole may be in a different position. (For example, if the manufacture recommends 3 quarts of fluid, make sure the diff has 3 quarts of fluid). Check your specific manual for correct amount of fluid.

### ***Recommend Tires and Wheels:***

Use 33/12.50R18 tire w/ 18x9 wheels w/ 5 3/4" BS w/ minor trimming

Use 33/12.50R20 tire w/ 20x9 wheels w/ 5 3/4" BS w/ minor trimming

Use 35/13.50R18 tire w/ 18x9 wheels w/ 5 3/4" BS w/ fenderwell cutting

Use 35/13.50R20 tire w/ 20x9 wheels w/ 5 3/4" BS w/ fenderwell cutting

# - INSTRUCTIONS -

## FRONT SUSPENSION

1. Disconnect the negative terminal on the battery. Jack up the front end of the truck and support the frame rails with jack stands. **NEVER WORK UNDER AN UNSUPPORTED VEHICLE!** Remove the front tires.
2. Locate the torsion bar adjusting keys and threaded bolts. Measure exposed threads of torsion bar adjusting bolts and record for reinstallation. Mark torsion bars indicating driver and passenger. Using a torsion bar removal tool, unload the torsion bars and remove the crossmember and bars. Retain the hardware for reinstallation. NOTE- Do not attempt to unload or remove torsion bars without the proper torsion bar tool. Torsion Bars are under extreme spring load.
3. Remove the sway bar link ends from the lower control arm.
4. Beginning on the driver's side, disconnect the tie rod end from the steering knuckle by striking the knuckle to dislodge the tie rod end. **SEE FIGURE 1**

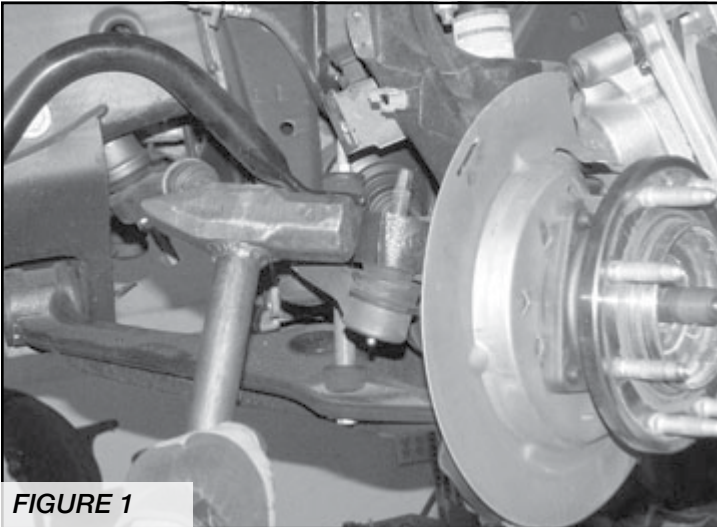


FIGURE 1

5. Remove the brake hose bracket from the top of the steering knuckle. Remove the caliper from the rotor and place above the upper control arm during this portion of the installation. Remove brake rotor from the steering knuckle. Unbolt the wheel speed sensor connection from the hub and control arm. **SEE FIGURE 2**

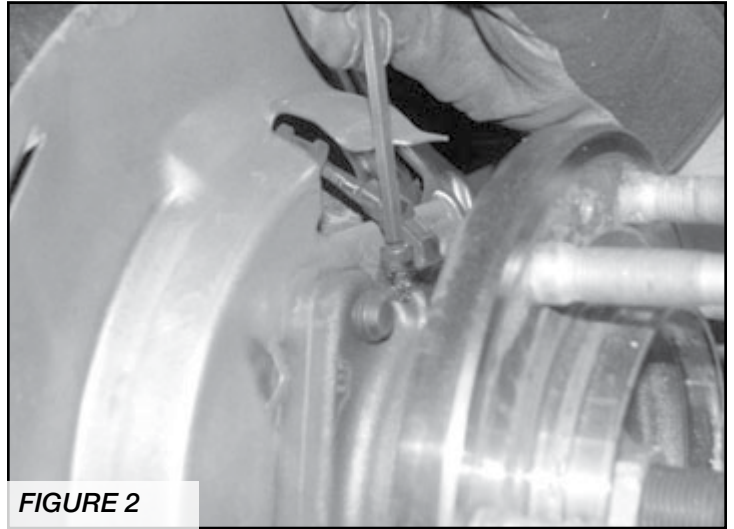


FIGURE 2

6. Remove axle nut, washer and the 4 hub bolts on backside of knuckle. Remove bearing hub assembly including O-ring from knuckle. Retain parts and hardware for reinstallation.
7. Remove the upper and lower ball joint nuts. Disconnect the upper and lower ball joints from the steering knuckle by striking the knuckle with a large hammer next to each ball joint on the knuckle to dislodge the ball joints. Use care not to hit the ball joints when removing. Retain nuts and discard knuckle. **SEE FIGURE 3**

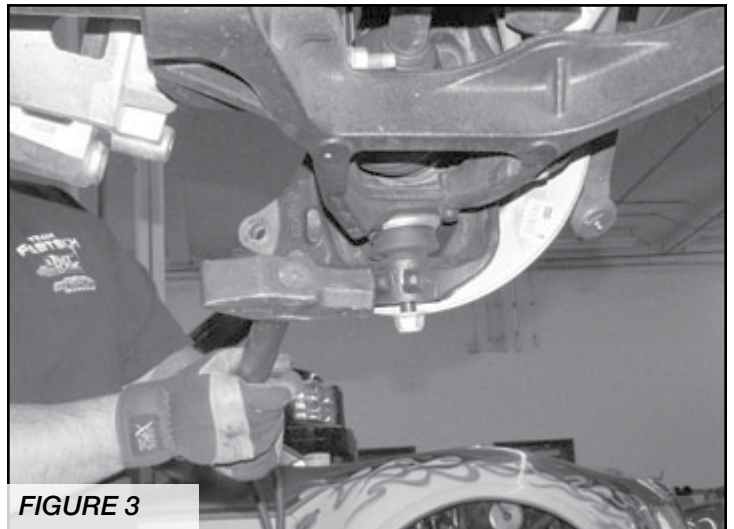
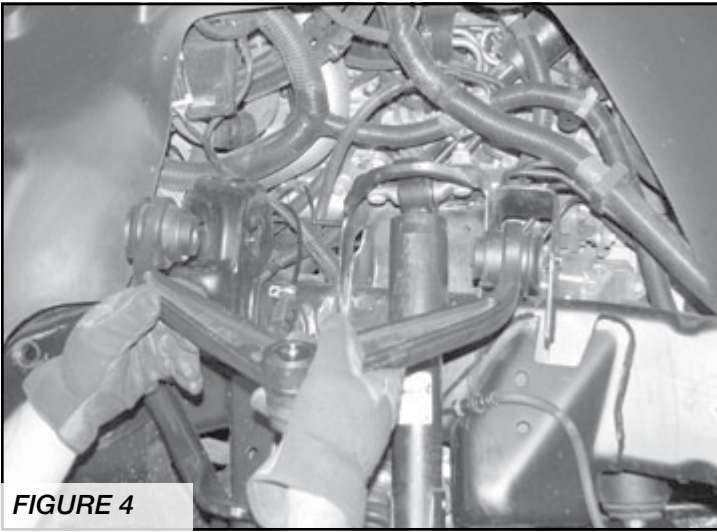


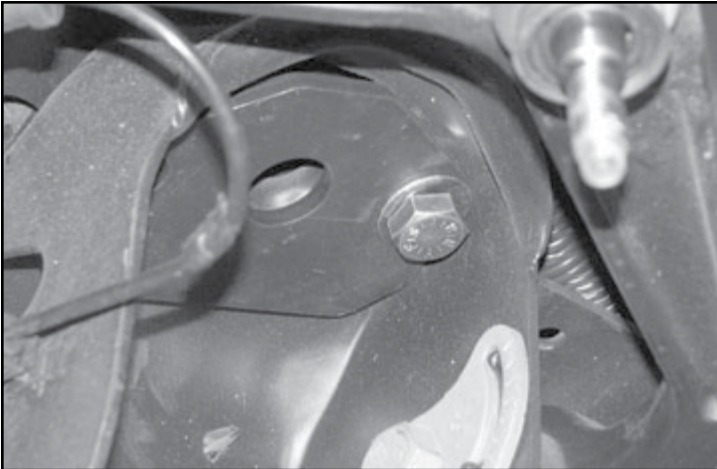
FIGURE 3

8. Mark the location of the alignment cams on the frame of the upper control arm pocket. Remove the upper control arm. Retain the factory hardware. **SEE FIGURE 4**



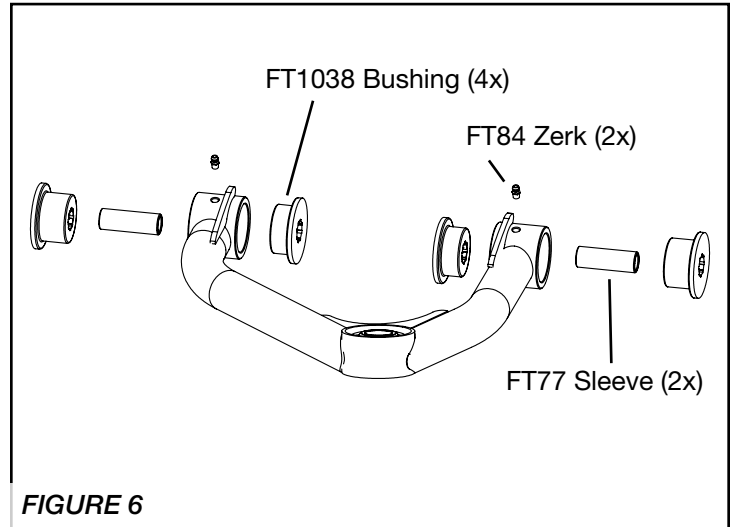
**FIGURE 4**

9. Remove the factory shock and discard.
10. Locate the FTS7341 shock and install using the factory lower hardware. Torque the upper bar pin bolts to 60 ft-lbs and the lower to 129 ft-lbs.
11. If installing Dirt Logic shocks, install the upper shock mount (FT20484) into the factory upper shock tower using the using two 9/16"-12 x 1-1/4", washers and lock nuts. If installing FTS6341 (stealth) without blue shaft seal install FT20740. If your FTS6341 has a blue shaft seal you do not have to install the FT20740. **SEE FIGURE 5**

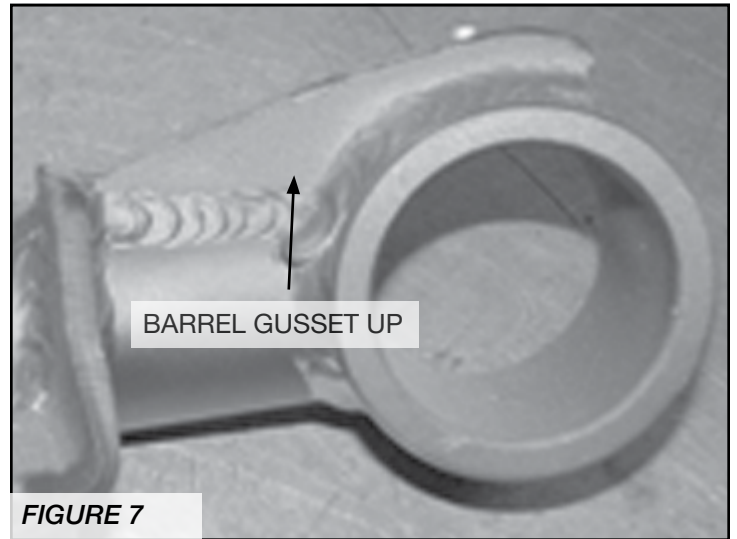


**FIGURE 5**

12. Install the front shock (FTS810932) with the stem in the upper mount.
13. Locate the Fabtech driver's side control arm FT20575BK, four bushings FT1038, two grease zerks FT84 and two sleeves FT77.
14. Install all these components in the control arm barrels. **SEE FIGURES 6-7**



**FIGURE 6**

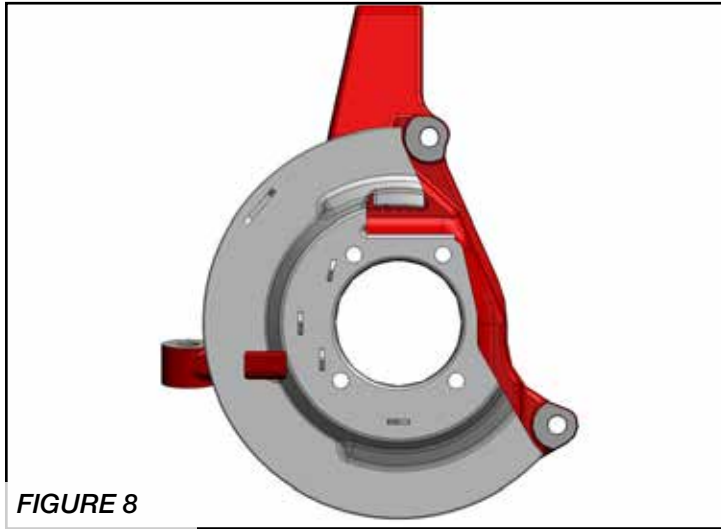


**FIGURE 7**

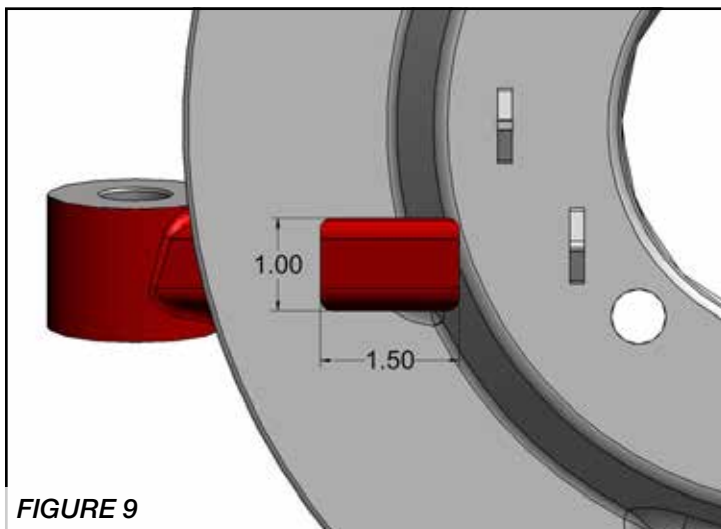
15. Install the new Fabtech upper control arm in the factory upper control arm pockets using the factory hardware at the previously marked alignment cam location. When installing the arm on the truck, make sure the barrel gussets are up. Torque to 150 ft- lbs and lube zerks with grease.

16. Locate the new Fabtech driver side spindle FTS20503D. Locate the o-ring, dust shield and hub. Clearance dust shield as necessary. Install onto the Fabtech spindle. Torque the factory hub bolts to 184 ft-lbs.

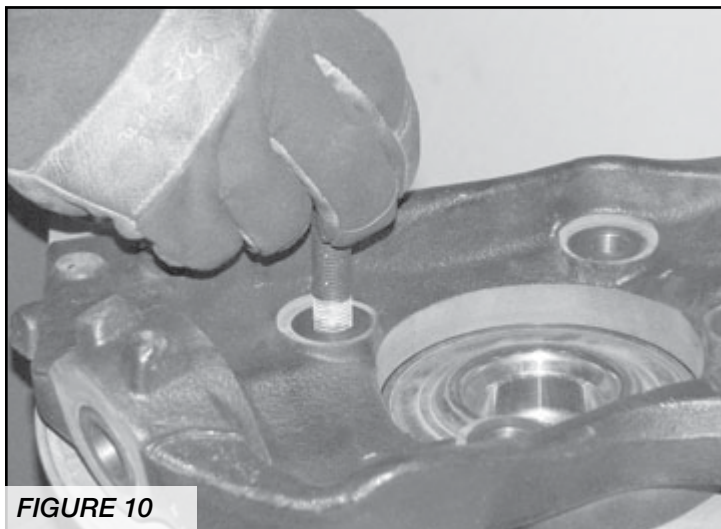
**SEE FIGURES 8-10**



**FIGURE 8**



**FIGURE 9**



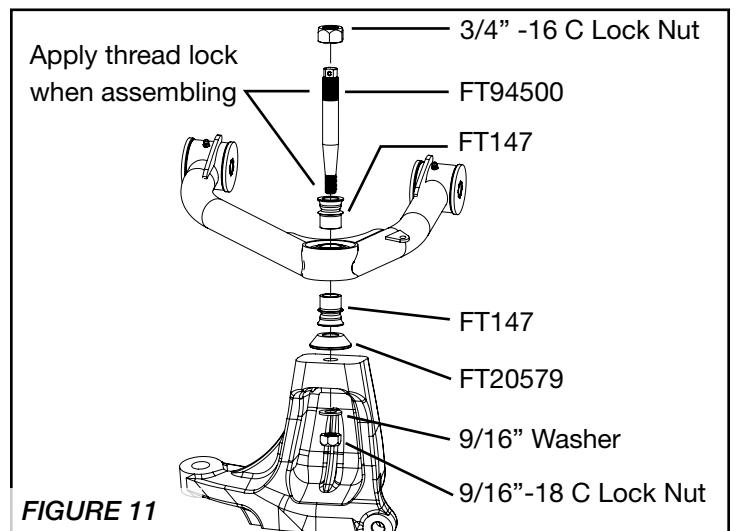
**FIGURE 10**

17. Install the Fabtech knuckle onto the lower ball joint. Pull the CV shaft back through the Hub. Torque the lower ball joint to 100 ft-lbs.

18. Locate FT94500 Uniball adapter pin and two FT147 uniball misalignment spacers.

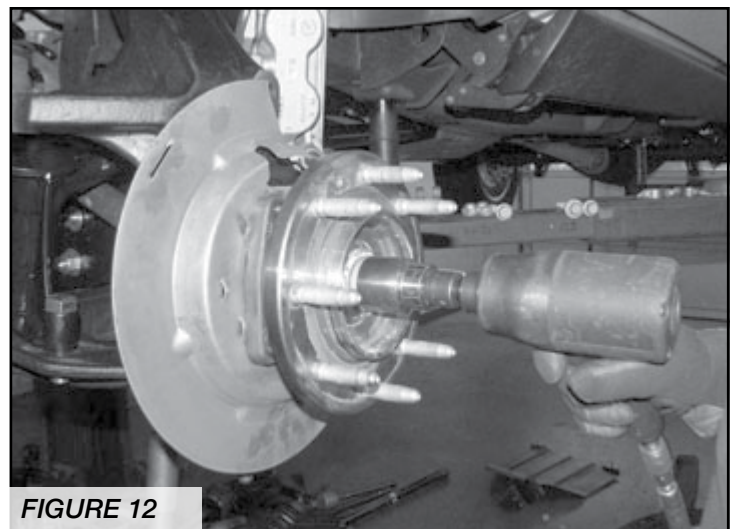
**SEE FIGURE 11 FOR STEPS 19-24**

19. Insert the uniball pin into the factory knuckle upper ball joint taper. Install the 9/16"-18 lock nut with thread lock compound and flat washer onto the bottom side of the pin. This will lock the pin into the knuckle. Torque to 150 ft-lbs.
20. Install one FT20579 uniball spacer onto the uniball pin mounted in the knuckle with the large side toward the knuckle.
21. Install one FT147 uniball misalignment spacer onto the pin.
22. Swing the control arm down, slide the pin into the uniball on the control arm seating the lower FT147 spacer in the control arm.
23. Install the upper FT147 uniball misalignment spacer onto the pin.
24. Install the 3/4" -16 lock nut on the top side of the pin with thread lock compound and torque to 150 ft-lbs.



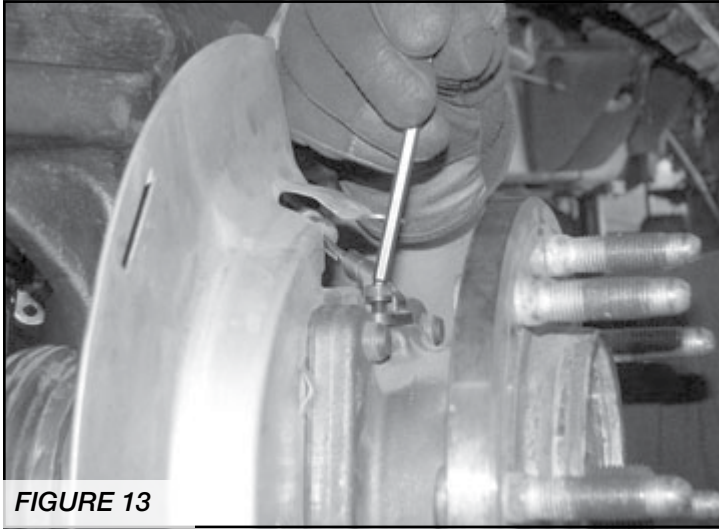
**FIGURE 11**

25. Install the axle nut and torque to 165 ft-lbs. Replace axle nut cover. **SEE FIGURE 12**



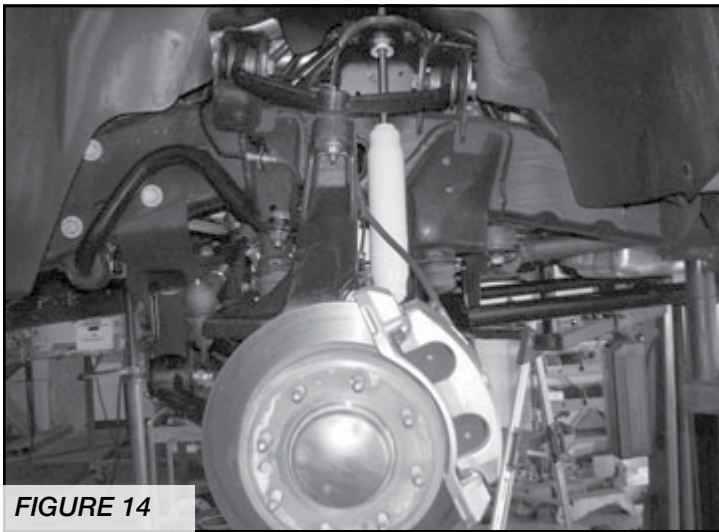
**FIGURE 12**

26. Install the wheel speed sensor into the factory hub.  
**SEE FIGURE 13**



**FIGURE 13**

27. Install the factory tie rod end into the Fabtech spindle and torque to 120 ft-lbs.
28. Install the rotor and the small bolt retaining the rotor and torque to 12 ft-lbs. Install the caliper and torque to 220 ft-lbs. **SEE FIGURE 14**

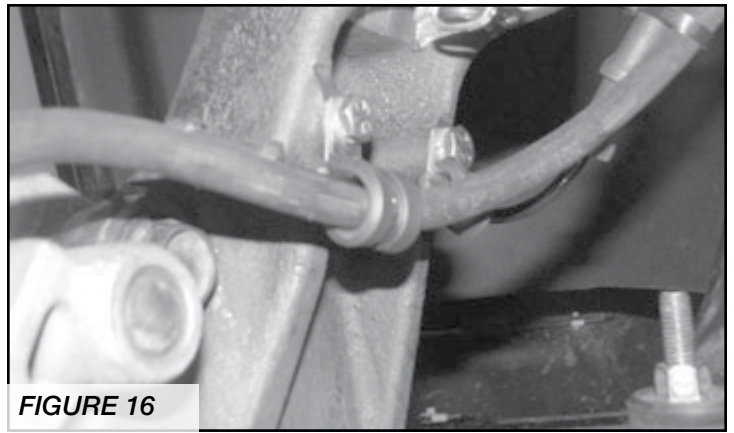


**FIGURE 14**

29. Locate the supplied adel clamps, 1/4" lock washers and 1/4"- 20 x 3/4" bolts. Clamp the brake line and the wheel speed wire to the spindle. **SEE FIGURES 15-16**



**FIGURE 15**



**FIGURE 16**

30. Repeat steps 4 – 29 on the passenger side.
31. Locate the factory driver side torsion bar, crossmember and the FT20550 torsion key. Install the torsion bars crossmember and the new Fabtech torsion key. The torsion bar key adjuster bolt should be reset to the measurement taken before the insulation. This is a temporary setting. When the Vehicle is on its own weight the measurement should 1/2" from the bottom side of the upper control arm to the droop stop. Adjust torsion bars accordingly.

## REAR SUSPENSION

*If installing rear blocks, otherwise skip to step 34*

32. Jack up the rear end of the vehicle and support the frame rails with jack stands. Supporting the rear differential, remove and discard the rear shocks and u-bolts. Lower axle down slowly. Use care not to over extend the brake hose.
33. Locate and install the rear lift blocks to the axle. Using the provided U bolts, nuts and washers, align axle, lift blocks, and springs and torque u-bolts to 317 ft-lbs.  
**SEE FIGURES 17-18**

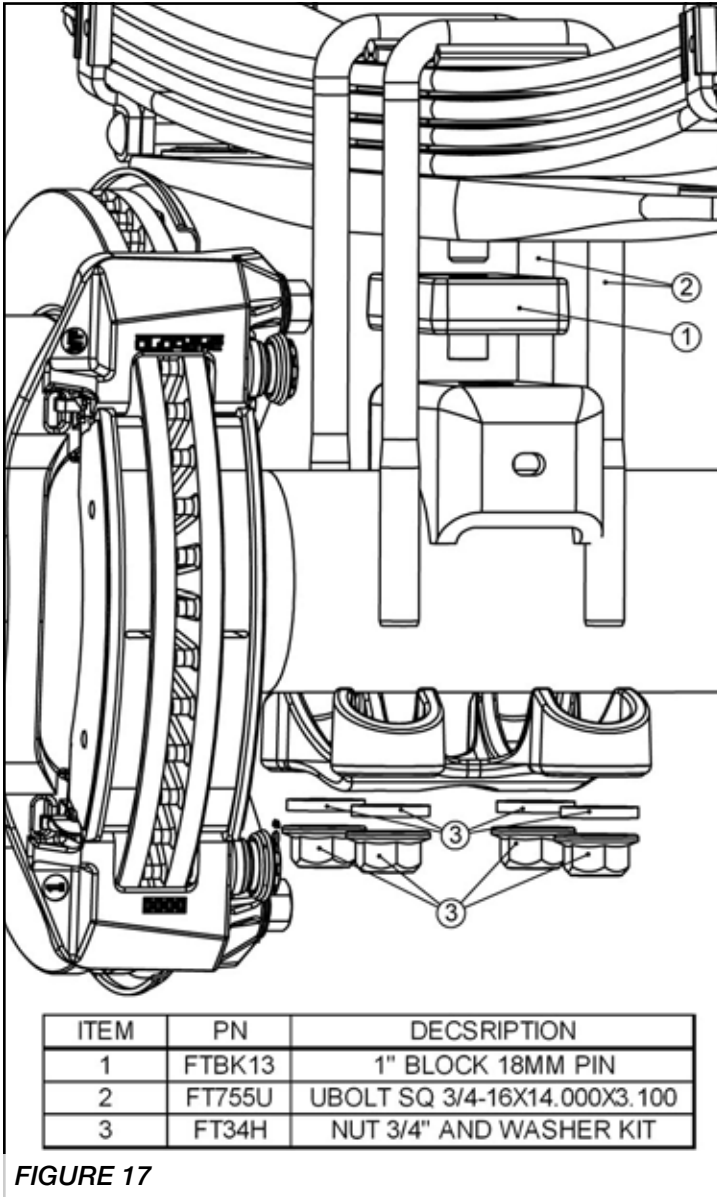


FIGURE 17

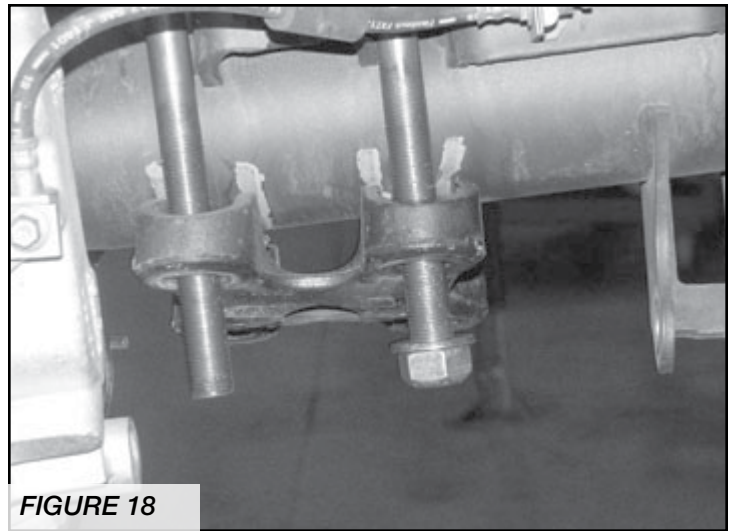


FIGURE 18

34. Install Fabtech shock part number FTS7299 or FTS810941. Torque bolts to 100 ft-lbs.
35. Install tires and wheels and torque lug nuts to wheel manufacturer's specifications. Turn front tires left to right and check for appropriate tire clearance. **Note - Some oversized tires may require trimming of the front bumper & valance.**
36. Recheck all bolts for proper torque.
37. Recheck brake hoses, ABS wires and suspension parts for proper tire clearance while turning tires fully left to right.
38. Check the fluid in the front and rear differential and fill if needed with factory specification differential oil. **Note - some differentials may expel fluid after filling and driving. This can be normal in resetting the fluid level with the new position of the differential/s.**
39. Install Driver Warning Decal. Complete product registration card and mail to Fabtech in order to receive future safety and technical bulletins on this suspension.
40. Have vehicle properly aligned to factory specs. Readjust headlights.