



## INSTALLATION INSTRUCTIONS



### 2019 GM 1500 4WD 3.5" UNIBALL UCA SUSPENSION KIT

**FTS21249**

**NOTE:** TO ORDER WEARABLE REPLACEMENT COMPONENTS DO NOT USE PART NUMBERS SHOWN ON THIS INSTRUCTION SHEET. GO TO FABTECH WEBSITE AND LOOK UP WEARABLE REPLACEMENT PARTS TO FIND THE PROPER PART NUMBER TO ORDER.

## - PARTS LIST -

| <b>FTS21249</b> |         | <b>3.5" UNIBALL UCA KIT</b>  |
|-----------------|---------|------------------------------|
| 1               | FT20868 | UPPER CONTROL ARM (DRIVER)   |
| 1               | FT20869 | UPPER CONTROL ARM (PASS)     |
| 4               | FT1500U | UBOLT 9/16-18 X 10.00 X 2.63 |
| 2               | FT20801 | COILOVER SPACER              |
| 1               | FT90118 | BUSHING KIT                  |
| 2               | FTBK15  | BLOCK 1.5"                   |
| 1               | FT20839 | HARDWARE SUBASSEMBLY         |

| <b>FT20839</b> |           | <b>HARDWARE SUBASSEMBLY</b> |
|----------------|-----------|-----------------------------|
| 2              | FT20835   | SPRING PERCH SPACER         |
| 8              | FT20836   | CONTROL ARM SPACER          |
| 1              | FT20865   | HARDWARE KIT                |
| 1              | FT21249i  | INSTRUCTIONS                |
| 2              | FT90152   | MISALIGNMENT (UPPER)        |
| 2              | FT90153   | MISALIGNMENT (LOWER)        |
| 1              | FT90154   | BEARING CAP                 |
| 2              | FT94531   | UNIBALL PIN                 |
| 1              | FTAS12    | STICKER FT BLUE 10X4        |
| 1              | FTAS16    | DRIVER WARNING DECAL        |
| 1              | FTREGCARD | REGISTRATION CARD           |

| <b>FT20865 - HARDWARE KIT</b> |                            | <b>LOCATION</b> |
|-------------------------------|----------------------------|-----------------|
| 8                             | 9/16 SAE WASHER            | UBOLT           |
| 8                             | 9/16-18 NYLOCK NUT         |                 |
| 4                             | 7/16-14 X 2-1/2 HEX BOLT   | LOWER STRUT     |
| 14                            | 7/16 SAE WASHER G8 ZINC    |                 |
| 4                             | 7/16-14 C-LOCK NUT ZINC    |                 |
| 6                             | 7/16-14 NYLOCK NUT         | COILOVER SPACER |
| 2                             | 1/2-20 X 1" - 12 PT BOLT   |                 |
| 2                             | 1/2-20 C-LOCK NUT          | UNIBALL PIN     |
| 2                             | 1/2" SAE WASHER            |                 |
| 8                             | 5/16-18 X 1" HEX BOLT      |                 |
| 4                             | FT84 GREASE FITTING 1/4-28 |                 |
| 4                             | ZIP TIE 8" BLACK           |                 |
| 1                             | THREAD LOCKING COMPOUND    |                 |

| <b>FTS21253</b> |           | <b>ADAPTIVE RIDE CONTROL SPACER KIT</b> |
|-----------------|-----------|---|
| 2               | FT20832   | SPRING PERCH SPACER                     |
| 2               | FT20673BK | REAR SHOCK BRACKET                      |
| 1               | FT20874   | HARDWARE KIT                            |

| <b>FT20874 - HARDWARE KIT</b> |                          | <b>LOCATION</b> |
|-------------------------------|--------------------------|-----------------|
| 2                             | 1/2-13 X 3-1/2" HEX BOLT | REAR SHOCK      |
| 4                             | 1/2" SAE WASHER          |                 |
| 2                             | 1/2-13 C-LOCK NUT        |                 |
| 2                             | M6-1.0 NUT               | CONTROL ARM     |
| 1                             | THREAD LOCKING COMPOUND  |                 |

## - TOOL LIST -

### *Required Tools (Not Included)*

- Basic Hand Tools
- Floor Jack
- Jack Stands
- Assorted Metric and S.A.E sockets, and Allen wrenches
- Torque Wrench
- Die Grinder w/ Cutoff Wheel or Sawzall
- Coil spring compressor

## - PRE-INSTALLATION NOTES -

### **READ THIS BEFORE YOU BEGIN INSTALLATION -**

Check all parts to the parts list above before beginning installation.

Read all instructions thoroughly from start to finish before beginning the installation. If these instructions are not properly followed severe frame, driveline and / or suspension damage may occur.

Check your local city and state laws prior to the installation of this system for legality. Do not install if not legal in your area.

Prior to the installation of this suspension system perform a front end alignment and record. Do not install this system if the vehicle alignment is not within factory specifications. Check for frame and suspension damage prior to installation.

The installation of this suspension system should be performed by two professional mechanics.

This suspension must be installed with Fabtech shock absorbers.

Use the provided thread locking compound on all hardware.

**WARNING-** Installation of this system will alter the center of gravity of the vehicle and may increase roll over as compared to stock.

Vehicles that receive oversized tires should check ball joints, uniballs, tie rods ends, pitman arm and idler arm every 2500-5000 miles for wear and replace as needed.

Verify differential fluid is at manufactures recommended level prior to kit installation. Installation of the kit will reposition the differential and the fill plug hole may be in a different position. (For example, if the manufacture recommends 3 quarts of fluid, make sure the diff has 3 quarts of fluid). Check your specific manual for correct amount of fluid.

### **FOOTNOTES -**

- Can not use OEM wheel and tire.
- Does not fit standard cab.
- Check with aftermarket wheel manufacturer for wheel compatibility on 2019 vehicle
- Does not fit GMC AT4 or Chevy Trail Boss models
- Does not fit 2019 Silverado LD or 2019 Sierra Limited models. Use 2018 applications for these vehicles.

# - INSTRUCTIONS -

## FRONT SUSPENSION

1. Disconnect the negative terminal on the battery. Jack up the front end of the truck and support the frame rails with jack stands. **NEVER WORK UNDER AN UNSUPPORTED VEHICLE!** Remove the front tires. **IMPORTANT:** Using a paint pen mark straight line down the center of the coilover at the top cap, lower spring perch and the lower mount. **SEE FIGURE 1**

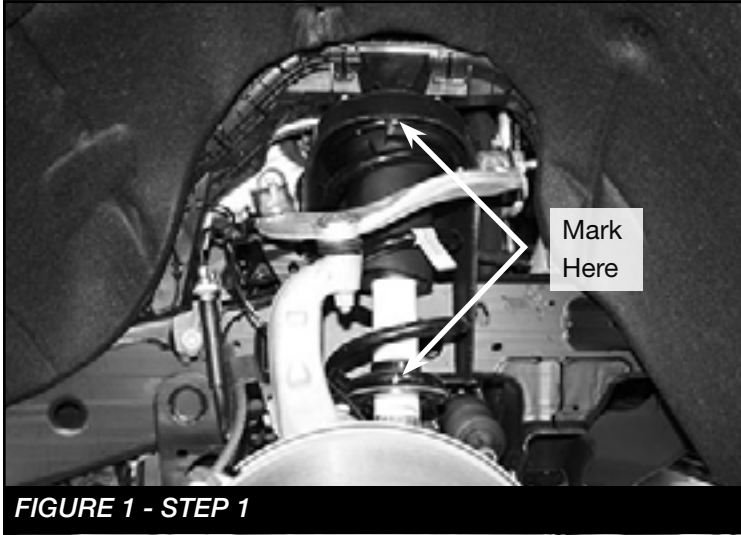

FIGURE 1 - STEP 1

2. Starting with the passenger side. Disconnect the ABS wire bracket from the upper control arm and the brake line bracket from the knuckle. Save hardware. **SEE FIGURES 2-3**

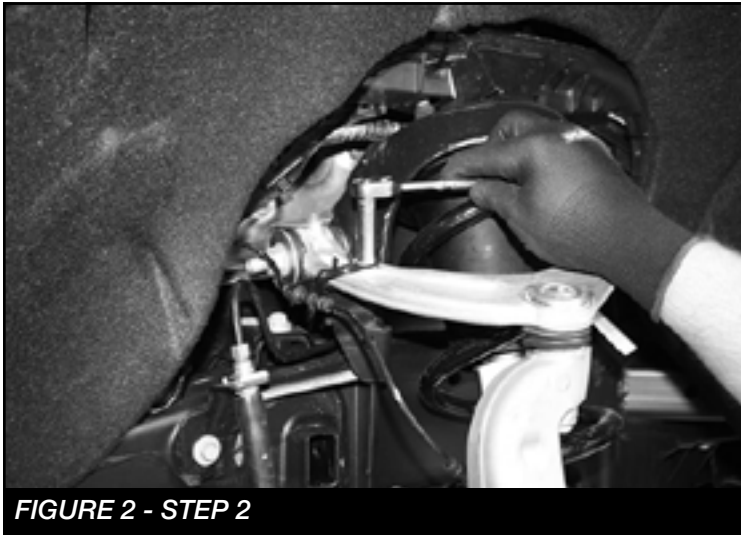

FIGURE 2 - STEP 2

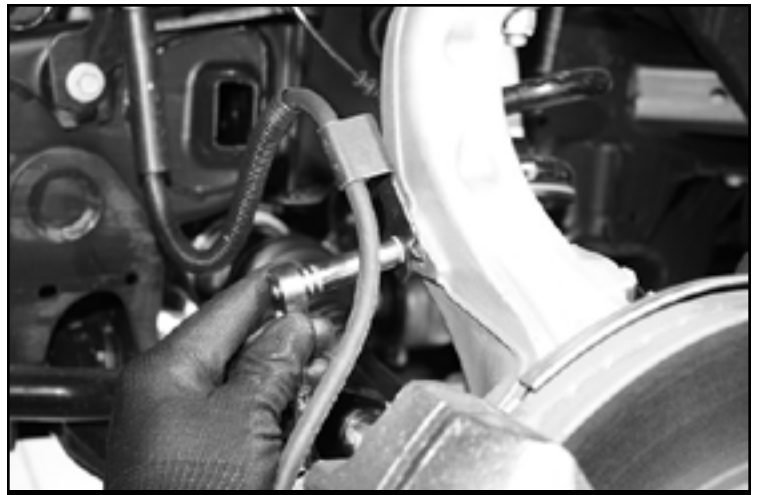

FIGURE 3 - STEP 3

3. Remove the factory tie rod end nut and strike the knuckle with a hammer till the tie rod end comes loose. Save all hardware. Use care not to hit any other parts. **SEE FIGURES 4-5**

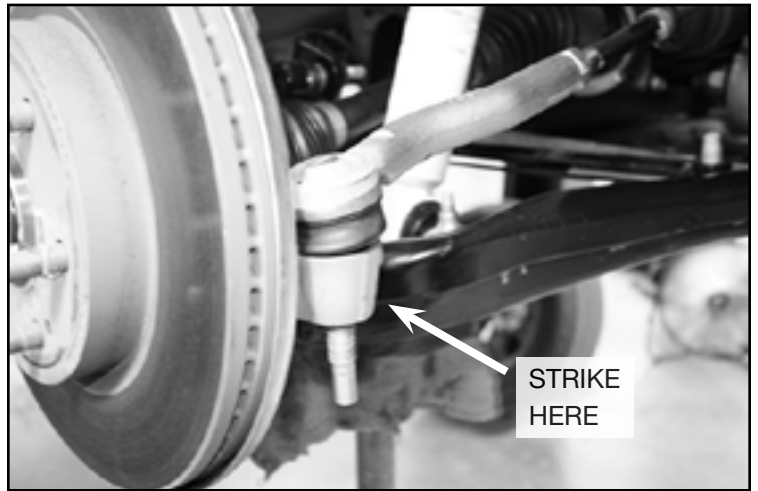

FIGURE 4 - STEP 3

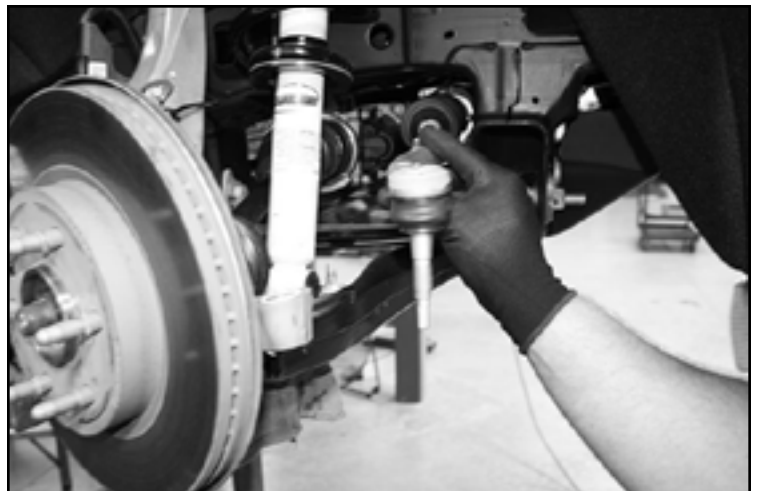

FIGURE 5 - STEP 3

4. Using a 36mm socket, remove and save the axle hub nut. **SEE FIGURE 6**



**FIGURE 6 - STEP 4**

5. Remove and save the sway bar link nut from the bottom side of the lower control arm. **SEE FIGURE 7**



**FIGURE 7 - STEP 5**

6. Loosen the upper ball joint nut and strike the knuckle with a hammer until it comes loose from the upper control arm. Next, remove the factory nut. Then, detach the knuckle from the upper control arm. Push the knuckle to the side and secure if possible. **SEE FIGURE 8**

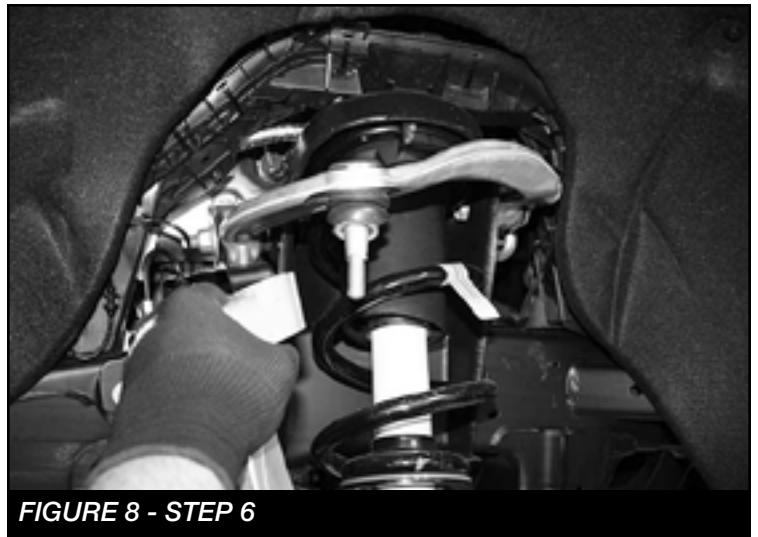

**FIGURE 8 - STEP 6**

7. Locate the plastic wire harness channel on the top of the passenger side coilover mount. Push it up and back to allow access to the three coilover nuts. Remove and discard the upper coilover nuts. **Adaptive Ride Control models only: Disconnect the wiring plug from the lower strut body and disconnect the adjusting rod from the upper control arm. SEE FIGURES 9-10**

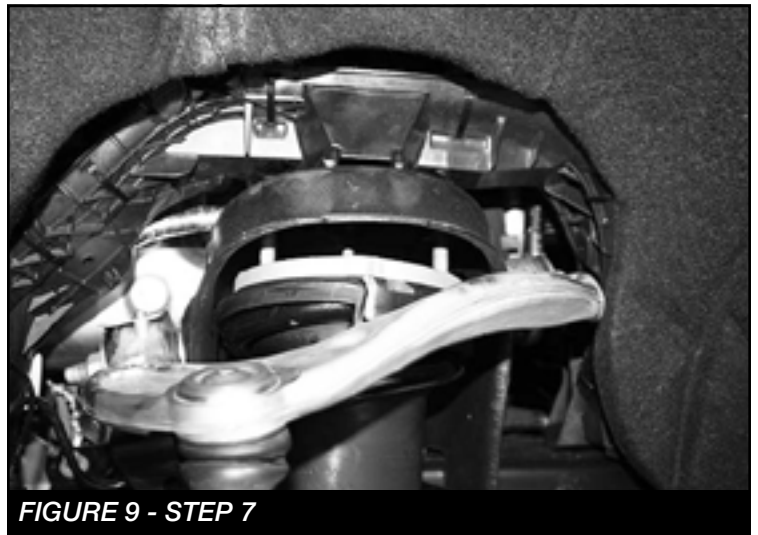

**FIGURE 9 - STEP 7**

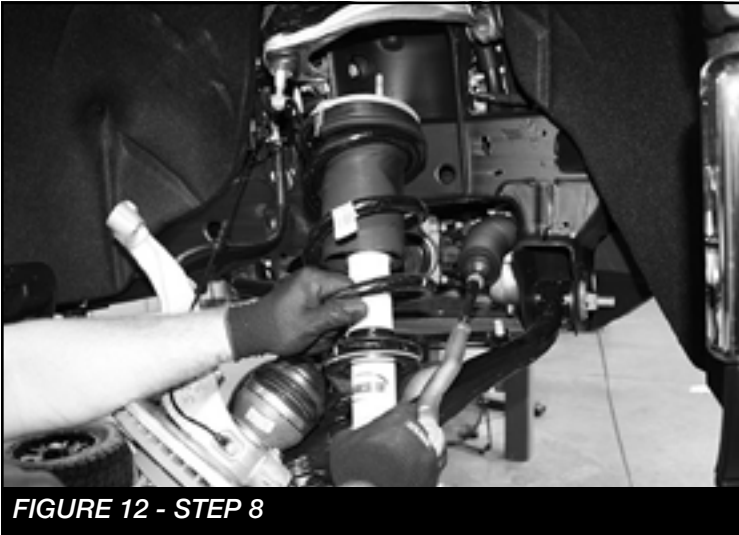

**FIGURE 10 - STEP 7**

8. Remove and discard the two lower coilover bolts. Then remove the coilover assembly from the vehicle. **SEE FIGURES 11-12**

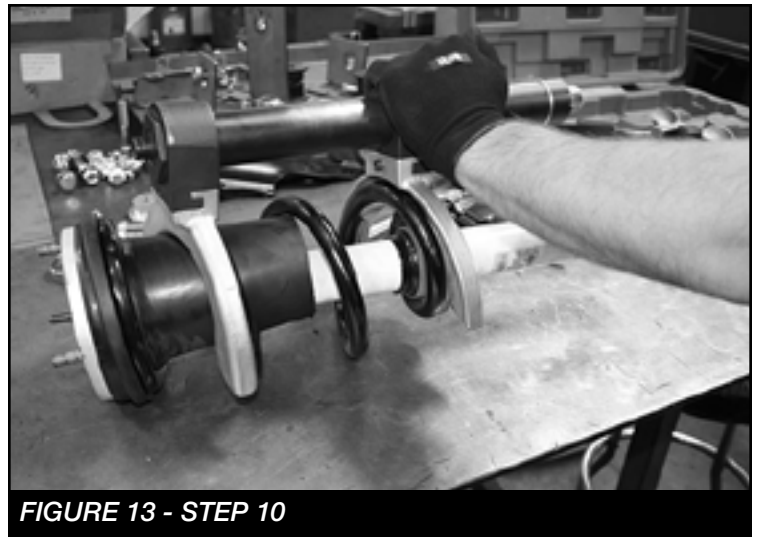

**FIGURE 11 - STEP 8**



**FIGURE 12 - STEP 8**

9. Remove the factory upper control arm from the vehicle and save the hardware. Repeat steps 1-8 on the driver side.
10. **NOTE: If vehicle is equipped with Adaptive Ride Control skip to Step 16.** Using a coil spring compressor. Carefully compress the coil spring until there is no pressure on the upper top cap. Loosen and remove the top cap nut then top cap and dust boot. **SEE FIGURES 13-14**



**FIGURE 13 - STEP 10**



**FIGURE 14 - STEP 10**

11. Remove the coil from the strut and set aside.
12. Remove the bump stop cap and save. Then, slide off the lower coil spring perch. **SEE FIGURES 15-17**



**FIGURE 15 - STEP 12**

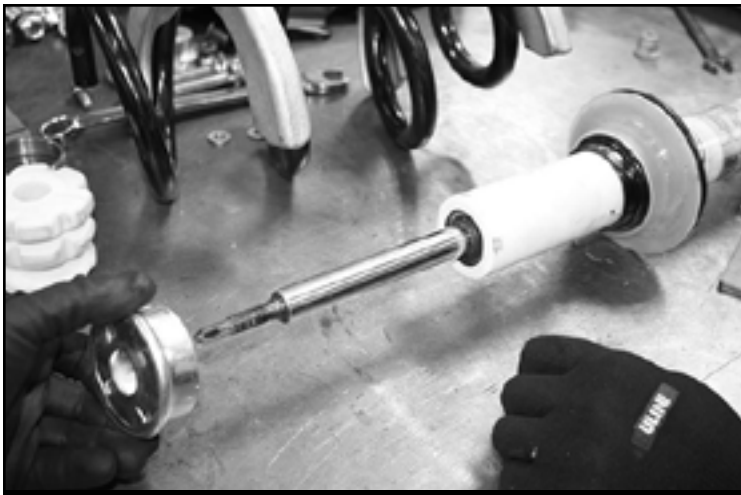

FIGURE 16 - STEP 12

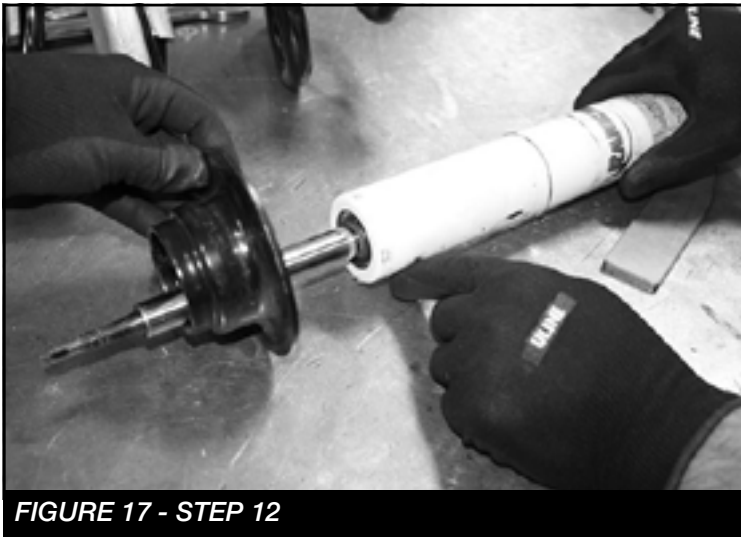

FIGURE 17 - STEP 12

13. Install FT20835 (Spring perch spacer) onto the strut. **Note:** the machined groove will seat around the lip on the strut body. SEE FIGURES 18-19

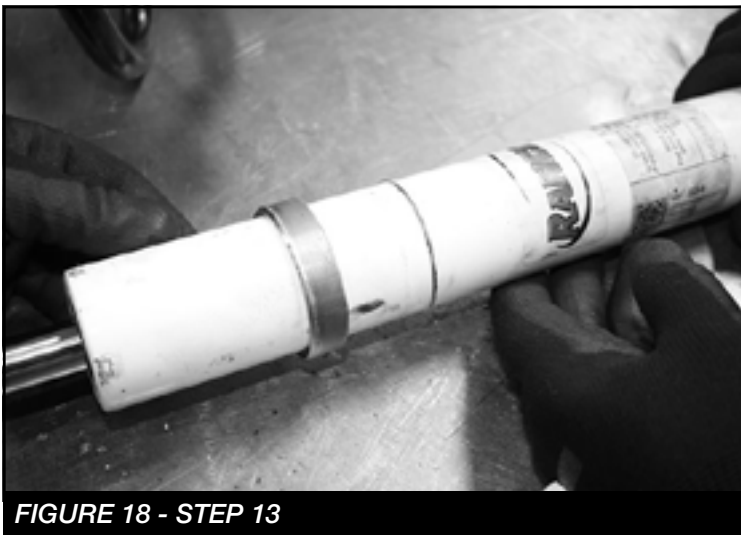

FIGURE 18 - STEP 13

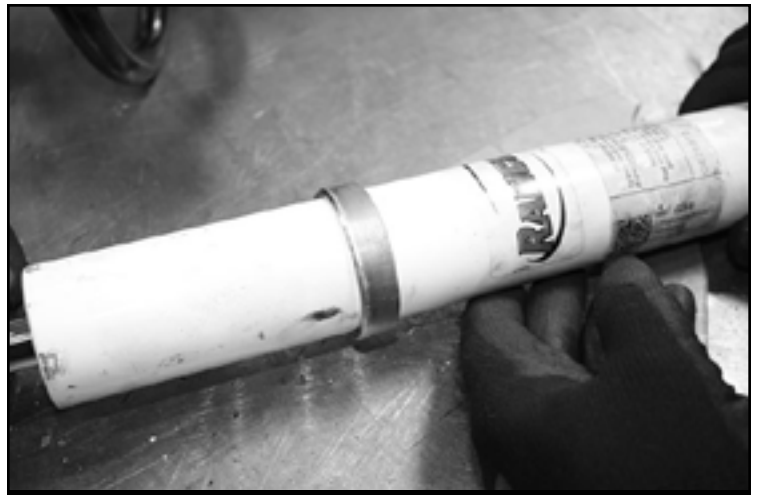

FIGURE 19 - STEP 13

14. Reinstall the lower spring perch. **SEE FIGURE 20**

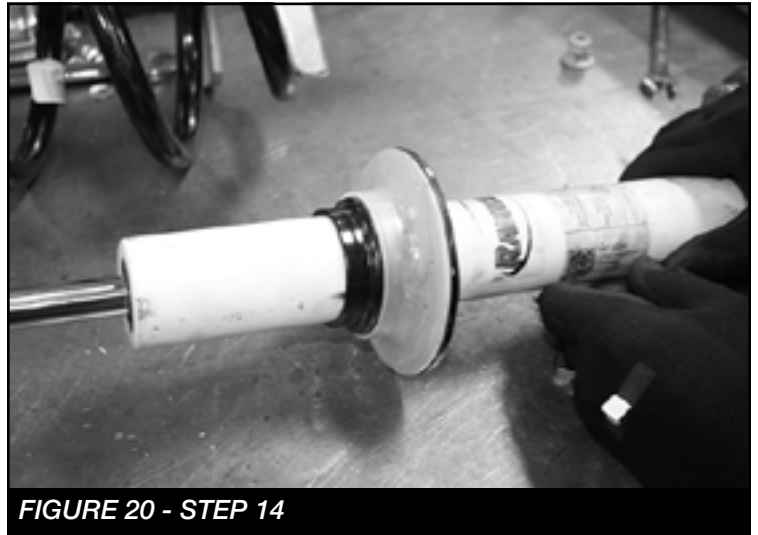

FIGURE 20 - STEP 14

15. Reinstall the bumpstop cap, compressed coil spring and the top cap and nut. **NOTE:** Before you remove the compressor make sure your marks are lined up from the top cap, lower perch and lower mount that were marked in step 1. Torque the top cap nut to 35 ft-lbs.

16. **ADAPTIVE RIDE CONTROL ONLY:** Using a coil spring compressor. Carefully compress the coil spring until there is no pressure on the upper top cap. Loosen and remove the top cap nut then top cap and dust boot. Remove coil and set aside. **SEE FIGURES 21-23**

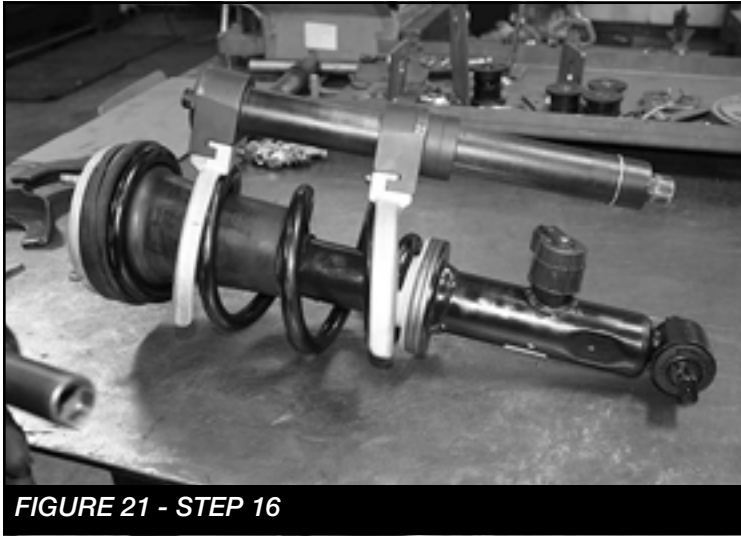

FIGURE 21 - STEP 16



FIGURE 22 - STEP 16



FIGURE 23 - STEP 16

17. Remove the foam bump stop, struct body cap and save. Then, slide off the lower coil spring perch plastic isolator. **SEE FIGURE 24**



FIGURE 24 - STEP 17

18. Install FT20832 (Spring perch spacer) onto the strut. Then, reinstall the plastic isolator onto the new spacer. Reinstall the cap and foam bumpstop. **SEE FIGURES 25-28**

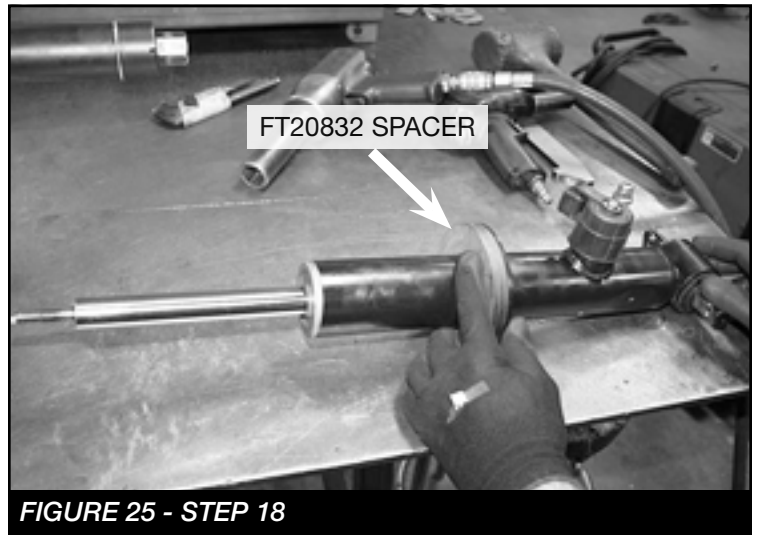

FIGURE 25 - STEP 18

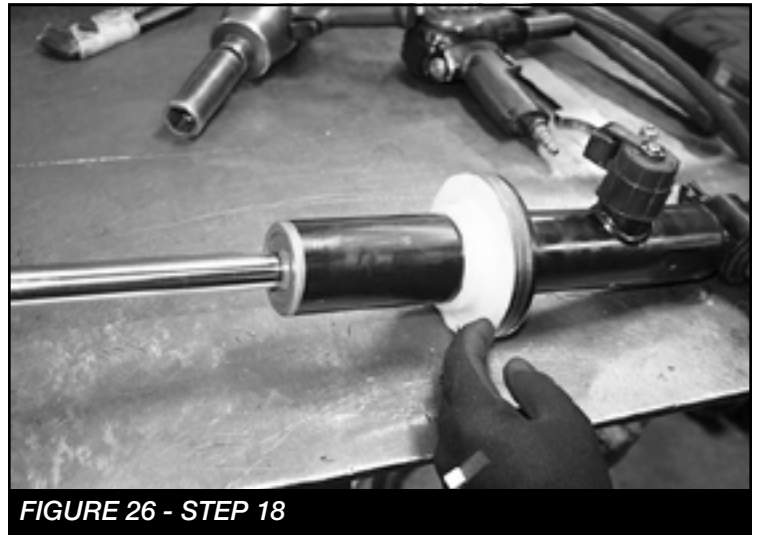

FIGURE 26 - STEP 18



FIGURE 27 - STEP 18



FIGURE 28 - STEP 18

19. Reinstall the bumpstop cap, compressed coil spring and the top cap and nut. **NOTE: Before you remove the compressor make sure your marks are lined up from the top cap, lower perch and lower mount that were marked in step 1.** Torque the top cap nut to 78 ft-lbs.

20. Locate the three top cap studs. Measure and mark 1-1/8" from the base of the studs. Using a cut off wheel, cut the excess of the stud off. **SEE FIGURE 29**

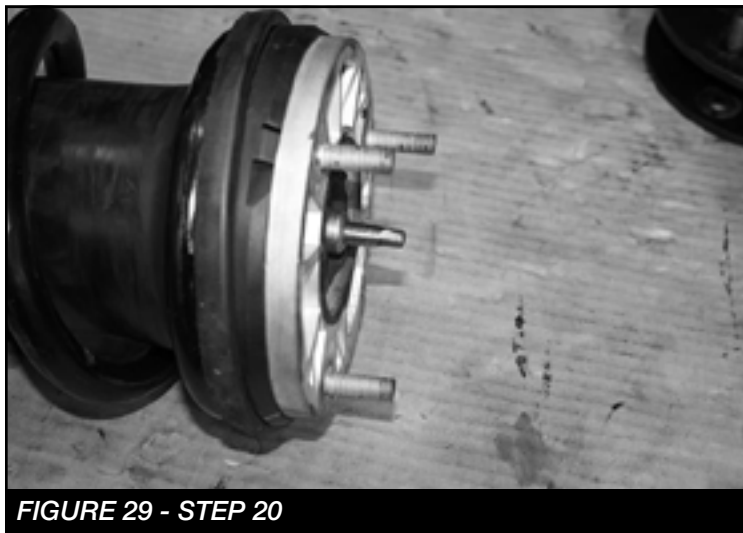

FIGURE 29 - STEP 20

21. Install FT20801 (Coilover spacer) onto the factory strut using the factory hardware. Torque to 68 ft-lbs. **SEE FIGURE 30**

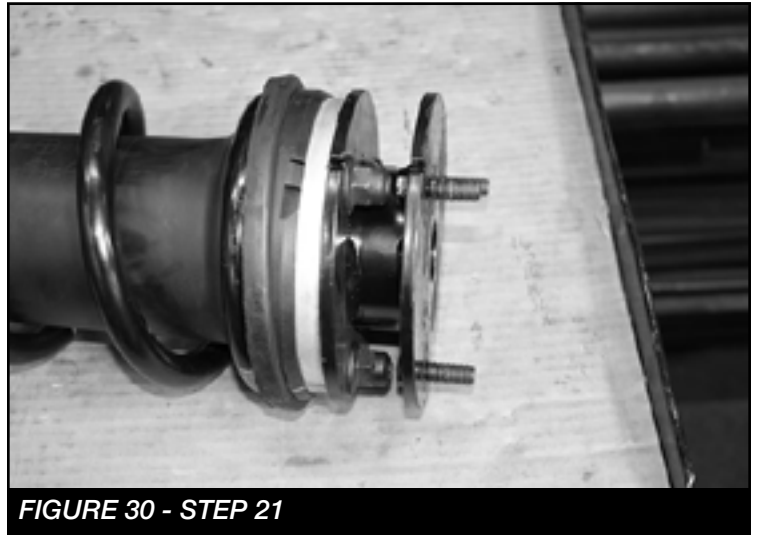

FIGURE 30 - STEP 21

22. Repeat steps on the driver side.

23. Locate the new Fabtech control arms, install two FT1002 bushings, two FT1001 bushings, two FT84 grease zerks, and two sleeves from the FT90118 (Bushing kit). **SEE FIGURE 31**

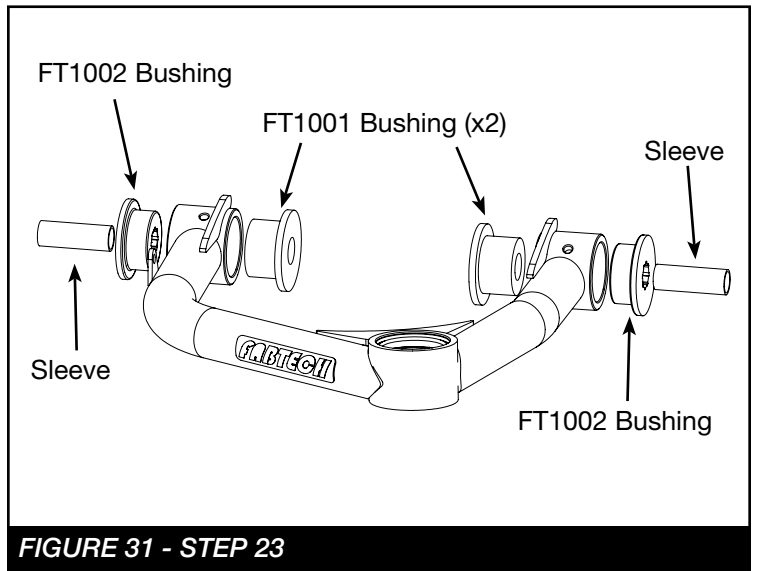

FIGURE 31 - STEP 23

24. Locate the factory bumpstop tabs on the frame mount. Using a cutoff wheel, remove this tab completely off the mount and sand to a smooth finish. **SEE FIGURES 32-33**

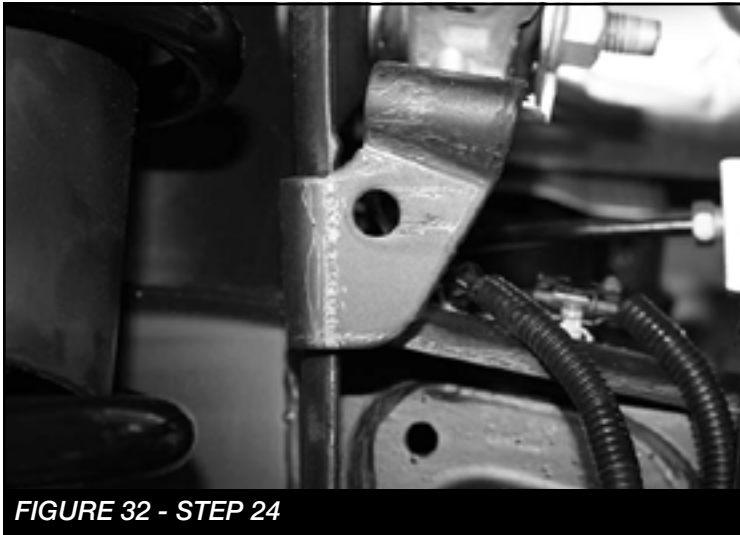

FIGURE 32 - STEP 24



FIGURE 33 - STEP 24

25. Install the FT20868 (Driver) & FT20869 (Pass) upper control arms using the factory bolts. Install the bolts with the bolt head inside the tower and the threaded end outside. **NOTE: When installing the arms, install a FT20836 (washer) on both sides of the bushings. Do not tighten at this time. Final locktite/ torque procedure will be done at step 34. SEE FIGURE 34**

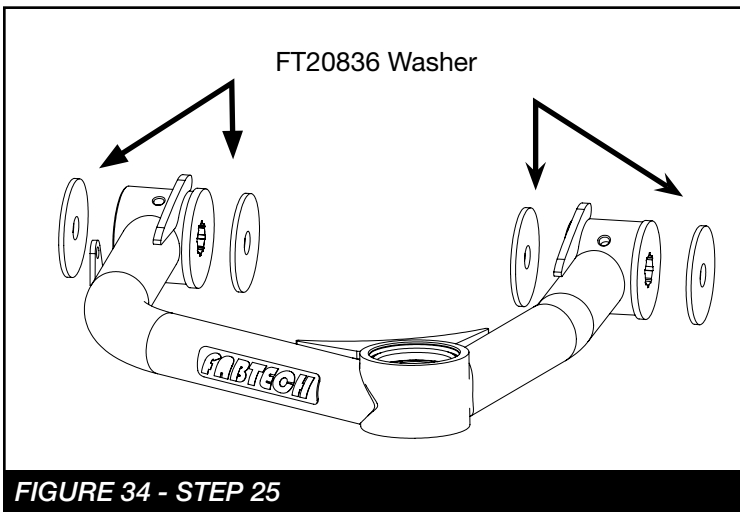

FIGURE 34 - STEP 25

26. Remove the factory nut clips on both of the factory lower struts.
27. Install the coil over into the upper shock mount using the supplied 7/16" Nylock nuts and washers. Leave loose at this time. **SEE FIGURE 35**

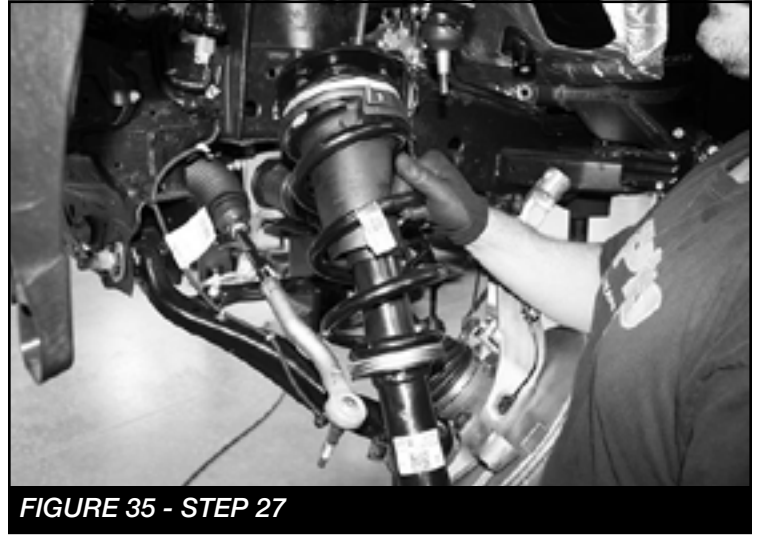

FIGURE 35 - STEP 27

28. Locate the two 7/16"-14 x 2-1/2" bolts, nuts and washers and install the lower bar pin mount onto the lower control arm. Torque the upper and lower bolts to 83 ft-lbs. **SEE FIGURE 36**



FIGURE 36 - STEP 28

29. Repeat steps 27-28 on the opposite side.

30. Install FT90153 (Lower misalignment) onto FT94531 (Uniball Pin). Then, install into the factory control arm using the supplied 1/2" nut and washer. Torque the nut to 120 ft-lbs. using a 15/16" open end wrench on the pin end. **SEE FIGURES 37-38**

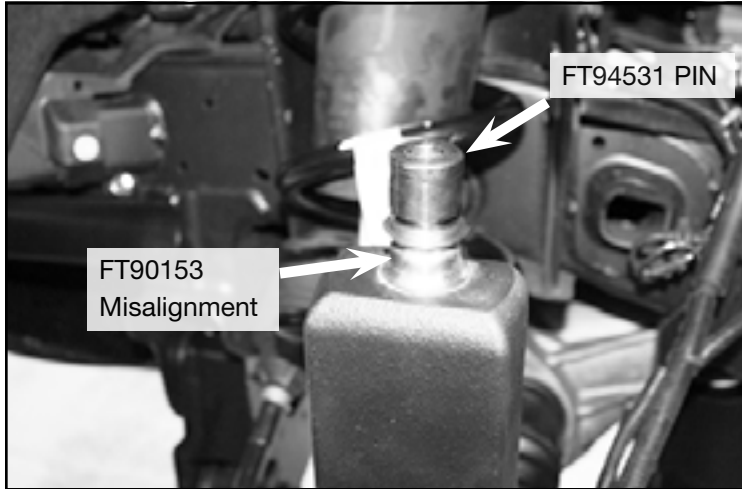

FIGURE 37 - STEP 30



FIGURE 38 - STEP 30

31. Attach the new upper control arm to the knuckle by inserting the FT90152 (Upper misalignment) into the uniball bearing then the 1/2-20 - 12 point bolt. Torque to 120 ft-lbs. Install FT90154 (Bearing cap). **SEE FIGURE 39**

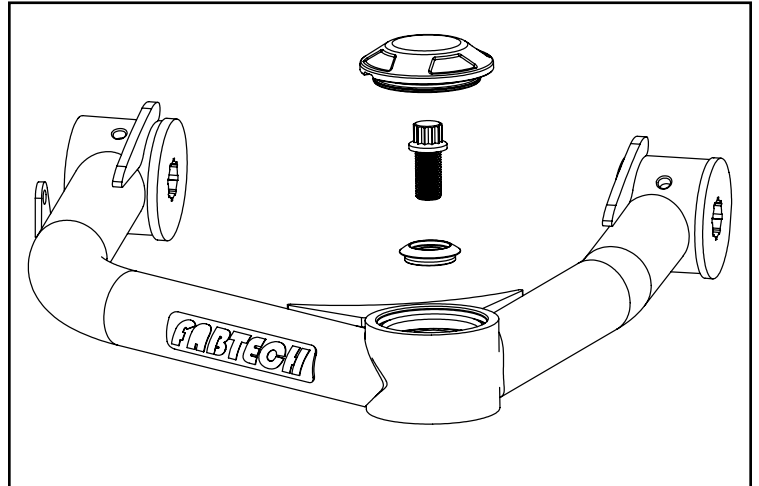

FIGURE 39 - STEP 31

32. Repeat steps on the passenger side.

33. Install the sway bar link to the lower control arm and the tie rod end to the knuckle torque all nuts to 35 ft-lbs. Reinstall the axle hub nut and torque to 156 ft-lbs. Attach the ABS line to the brake line hose and the brake line bracket to the knuckle. Torque to 11 ft-lbs.

34. Using the supplied thread lock torque the upper control arm frame pocket hardware to 160 ft-lbs. **NOTE: Removal of the nut may be necessary to install the thread lock compound.**

35. **ADAPTIVE RIDE CONTROL ONLY:** Install the ride control rod to the new Fabtech arm using the supplied M6 nut. Torque to 7 ft-lbs.

## REAR SUSPENSION

36. Jack up the rear end of the truck and support the frame rails with jack stands. **NEVER WORK UNDER AN UNSUPPORTED VEHICLE!** Remove the rear wheels/tires.
37. With the rear axle supported. Remove the rear shocks and save hardware. **NOTE: If working on a vehicle equipped with Adaptive Ride Control disconnect the shock at the lower mount only. Do not completely remove from vehicle.** Remove the factory ubolts.
38. Install the new FTBK15 (1.5" Blocks) and FT1500U (ubolts) using the supplied 9/16" nuts and washers. Torque to 130 ft-lbs.
39. Install rear shocks using FTS7333 (Performance shocks) or FTS6333 (Stealth Shocks) with factory hardware. Torque to 100 ft-lbs. **Adaptive ride control vehicles:** Install the FT20673BK (Rear shock ext) onto the shock using the supplied 1/2 x 3-1/2" hardware then install to the axle mount using the factory hardware. Torque to 106 ft-lbs.
40. Install tires and wheels and torque lug nuts to wheel manufacturer's specifications. Turn front tires left to right and check for appropriate tire clearance. **Note - Some oversized tires may require trimming of the front bumper & valance.**
41. Check front end alignment and set to factory specifications. Readjust headlights.
42. Recheck all bolts for proper torque.
43. Recheck brake hoses, ABS wires and suspension parts for proper tire clearance while turning tires fully left to right.
44. Check the fluid in the front and rear differential and fill if needed with factory specification differential oil. **Note - some differentials may expel fluid after filling an driving. This can be normal in resetting the fluid level with the new position of the differential/s.**
45. Install Driver Warning Decal. Complete product registration card and mail to Fabtech in order to receive future safety and technical bulletins on this suspension.

**Vehicles that will receive oversized tires should check ball joints, uniballs and all steering components every 2500-5000 miles for wear and replace as required.**

**RE-TORQUE ALL NUTS, BOLTS AND LUGS AFTER 50 MILES AND PERIODICALLY THEREAFTER.**