



INSTALLATION INSTRUCTIONS

K2284		6" 4-LINK SYSTEM W/PERF SHOCKS
1	FTS22251	6" COIL BOX
1	FTS22221	6" 4-LINK BOX 1
1	FTS22277	6" 4-LINK BOX 2
1	FTS22274	6" REAR BOX KIT
2	FTS7188	PERFORMANCE SHOCK (FRONT)
2	FTS7266	PERFORMANCE SHOCK (REAR)

K2284M		6" 4-LINK SYSTEM W/ STEALTH SHOCKS
1	FTS22251	6" COIL BOX
1	FTS22221	6" 4-LINK BOX 1
1	FTS22277	6" 4-LINK BOX 2
1	FTS22274	6" REAR BOX KIT
2	FTS6188	STEALTH MONOTUBE SHOCK (FRONT)
2	FTS6063	STEALTH MONOTUBE SHOCK (REAR)

K2284DL		6" 4-LINK SYSTEM W/ DLSS SHOCKS
1	FTS22251	6" COIL BOX
1	FTS22221	6" 4-LINK BOX 1
1	FTS22277	6" 4-LINK BOX 2
1	FTS22274	6" REAR BOX KIT
2	FTS810382	2.25 DIRT LOGIC SS N/R (FRONT)
2	FTS810052	2.25 DIRT LOGIC SS N/R (REAR)

2017 FORD F450/550 4WD 6" 4-LINK SYSTEM

FTS22277i

FTS22251 6" FORD F250/350 FRONT COILS		
2	FT30733	6" FRONT COIL

FTS22221 6" 4-LINK SYSTEM BOX 1		
2	FT30129BK	LOWER LINK
2	FT30692	UPPER LINK
2	FT30650	4-LINK POCKET

FTS22277 6" 4-LINK SYSTEM BOX 2		
1	FT30775	PITMAN ARM
1	FT3400-112D	SWAY BAR DROP (PASSENGER)
1	FT3400-112P	SWAY BAR DROP (DRIVER)
2	FT30456	SWAY BAR BRACKET (AXLE)
2	FT30654	6" BUMP STOP EXT
1	FT30724	TRAC BAR DROP BRACKET
1	FT30670	HARDWARE KIT
1	FT30672	STEERING STABILIZER BRACKET
1	FT30793	HARDWARE SUBASSEMBLY
1	FT30686	STEERING STABILIZER CLEVIS MOUNT

FT30793 HARDWARE SUBASSEMBLY		
8	FT147	MISALIGNMENT
1	FT22277i	INSTRUCTIONS
1	FT292	ALIGNMENT CAM KIT
1	FT30258	SECTOR SHAFT NUT
1	FT30604	SPACER
2	FT30660	BRAKE LINE TAB
2	FT50290	BUMP STOP NUT TAB
1	FTAS12	STICKER FT BLUE 10X4 DIE CUT
1	FTAS16	DRIVER WARNING DECAL
1	FTREGCARD	REGISTRATION CARD
2	HEX BOLT	1/2-13 X 1-1/2" HEX BOLT
2	C-LOCK NUT	1/2-13 C-LOCK NUT
4	WASHER	SAE WASHER

FT30779 HARDWARE SUBASSEMBLY		
2	FT160	SLEEVE .750 X .594 X .500
8	FT1004	SWAY BAR BUSHING HALF
1	FT50089	SLEEVE .625 X .507 X 1.480 (4-PACK)
1	FT30754	HARDWARE KIT
1	FTAS12	STICKER FT BLUE 10X4 DIE CUT
1	FTAS16	DRIVER WARNING DECAL
1	FTREGCARD	REGISTRATION CARD

FT30670- HARDWARE KIT		LOCATION
8	7/16 SAE WASHER G8 ZINC	SWAY BAR
4	7/16-14 C-LOCK NUT ZINC	
4	7/16-14 X 1 1/4 HEX HD	
2	3/8-16 X 1" HEX BOLT	BRAKE LINE
4	3/8" SAE WASHER	
2	3/8-16 NYLOCK NUT	
2	1/4 SAE WASHER	
1	1/4-20 GR C-LOCK NUT	
1	1/4-20 X 3/4 HEX BOLT G5 ZINC	
2	1/2-13 X 1-1/4 HEX BOLT	BUMP STOP
2	1/2-13 X 1-1/2 HEX BOLT	
6	1/2 SAE WASHER	
2	1/2-13 C-LOCK NUT	
4	3/4-10 X 1-1/2" HEX BOLT	4-LINK
2	3/4-10 X 5" HEX BOLT	
16	3/4 SAE WASHER	
8	3/4-10 C-LOCK NUT	
1	COTTER PIN	
1	M12-1.75 X 70MM HEX BOLT	STEERING STABILIZER
2	M12 WASHER	
1	M12-1.75 C-LOCK	
1	9/16-12 NYLOCK NUT	
3	9/16 SAE WASHER	
1	THREAD LOCKING COMPOUND 1 MIL	
1	HOSE CLAMP	

FT30754 - HARDWARE KIT		LOCATION
8	3/4-16 NYLOCK NUT	UBOLTS
8	3/4 SAE WASHER	
4	1/2-13 X 2-1/2" HEX BOLT	SWAY BAR
12	1/2 SAE WASHER	
6	1/2-13 C-LOCK NUT	
2	1/2-13 X 1-1/4 HEX BOLT	BUMPSTOP
1	THREAD LOCKING COMPOUND	

FTS22274 F450/550 REAR BOX KIT		
2	FT30784	SWAY BAR END LINK
2	FT30750	REAR BUMPSTOP EXTENSION
4	FT759U	U-BOLT RD 3/4-16 X 21.00 X 3.50
2	FTBK65	LIFT BLOCK
1	FTS419	DRIVE SHAFT SHIM KIT
1	FT30779	HARDWARE SUBASSEMBLY

- TOOL LIST -

Required Tools (Not Included)

- Basic Hand Tools
- Assorted Metric and S.A.E sockets, and Allen wrenches
- Torque Wrench
- Die Grinder w/ Cutoff Wheel or Sawzall
- 1-1/4" Hole Saw
- Basic Hand Tools
- Floor Jack
- Jack Stands
- Drill

- PRE-INSTALLATION NOTES -

READ THIS BEFORE YOU BEGIN INSTALLATION -

Check all parts to the parts list above before beginning installation.

Read all instructions thoroughly from start to finish before beginning the installation. If these instructions are not properly followed severe frame, driveline and / or suspension damage may occur.

Check your local city and state laws prior to the installation of this system for legality. Do not install if not legal in your area.

Prior to the installation of this suspension system perform a front end alignment and record. Do not install this system if the vehicle alignment is not within factory specifications. Check for frame and suspension damage prior to installation.

The installation of this suspension system should be performed by two professional mechanics.

This suspension must be installed with Fabtech shock absorbers.

Use the provided thread locking compound on all hardware.

WARNING- Installation of this system will alter the center of gravity of the vehicle and may increase roll over as compared to stock.

Vehicles that receive oversized tires should check ball joints, uniballs, tie rods ends, pitman arm and idler arm every 2500-5000 miles for wear and replace as needed.

Verify differential fluid is at manufactures recommended level prior to kit installation. Installation of the kit will reposition the differential and the fill plug hole may be in a different position. (For example, if the manufacture recommends 3 quarts of fluid, make sure the diff has 3 quarts of fluid). Check your specific manual for correct amount of fluid.

Recommend Tires and Wheels:

- Use 37/12.50R17 tire w/ 17x9 wheels w/ 4-3/4" BS w/ minor trimming
- Use 37/12.50R18 tire w/ 18x9 wheels w/ 4-3/4" BS w/ minor trimming
- Use 37/13.50R20 tire w/ 20x9 wheels w/ 5" BS w/ minor trimming

FOOTNOTES -

- SOME MODELS MAY NOT SIT LEVEL AFTER INSTALL

- INSTRUCTIONS -

FRONT SUSPENSION

1. Disconnect the negative terminal on the battery. Jack up the front end of the truck and support the frame rails with jack stands. **NEVER WORK UNDER AN UNSUPPORTED VEHICLE!** Remove the front tires.
2. Disconnect the sway bar from the sway bar end links and frame. Remove sway bar. Save hardware. **SEE FIGURE 1**



FIGURE 1 - STEP 2

3. Disconnect the brake line from the frame and axle on both driver and passenger sides. Save hardware. **SEE FIGURES 2-3**

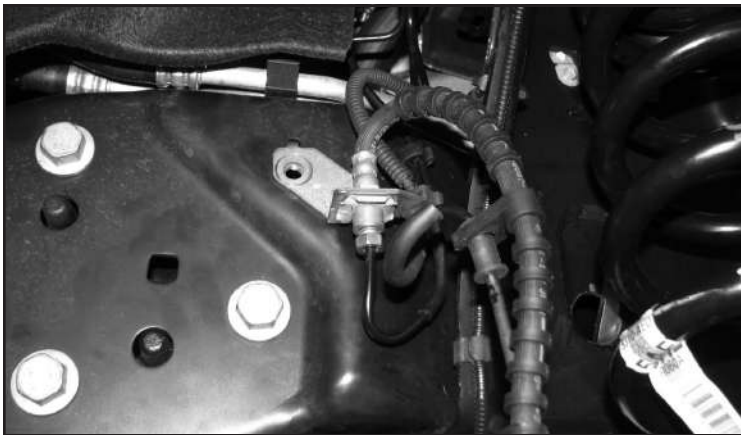


FIGURE 2 - STEP 3



FIGURE 3 - STEP 3

4. Remove the front shocks and discard, save hardware.
5. Lower the front axle allowing the coil springs to come free of tension and remove the coil springs. **EXERCISE EXTREME CAUTION WHEN WORKING WITH COIL SPRINGS UNDER LOAD!**
6. Disconnect the factory steering stabilizer from the frame mount. Remove the steering stabilizer frame bracket. Discard the frame bracket. Save all hardware.
7. Remove the drag link from the pitman arm. **Use care not to damage the threads on the drag link.**
8. Disconnect the trac bar from the frame bracket. Remove the trac bar bracket from the frame, save the original hardware and discard the factory trac bar bracket.
9. Remove the factory pitman arm from the steering box using a large pitman arm puller. Discard hardware and arm.
10. Install FT30775 (Pitman Arm) using the supplied FT30258 (Sector shaft nut). Torque to 350 ft-lbs. **NOTE: This is a one time only use nut. If remove, it must be discarded.**
11. Locate FT30724 (Track Bar Bracket). Attach to the frame using the original hardware in the same position. Torque bolts to 120 ft-lbs. **DO NOT ATTACH THE TRAC BAR TO THE FRAME BRACKET AT THIS TIME. SEE FIGURES 4-5**



FIGURE 4 - STEP 11



FIGURE 5 - STEP 11

12. Working from both sides of the truck, locate and remove the factory front bump stops and save. Pull on the bump stop itself to free from the cup. Remove the factory mounting cup from the frame and discard the hardware. Drill out the center hole on the factory cup to 1/2". **SEE FIGURES 6-7**



FIGURE 6 - STEP 12



FIGURE 7 - STEP 12

13. Install FT30654 (Bump Stop Extension) onto the factory cup using the supplied 1/2" x 1-1/4" hardware and set aside. Torque to 127 ft-lbs. **SEE FIGURE 8**

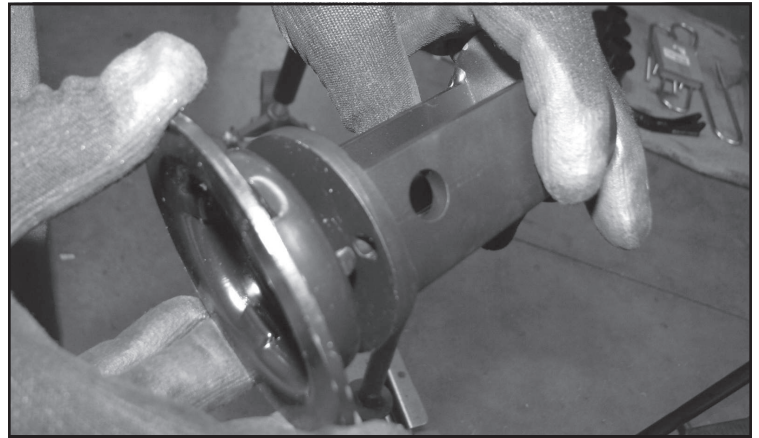


FIGURE 8 - STEP 13

14. Locate the factory bump stop mounting hole. Measure 3" straight up from the bottom of the frame. Mark and drill a 1-1/4" hole using a hole saw into the frame. **SEE FIGURES 9-10**

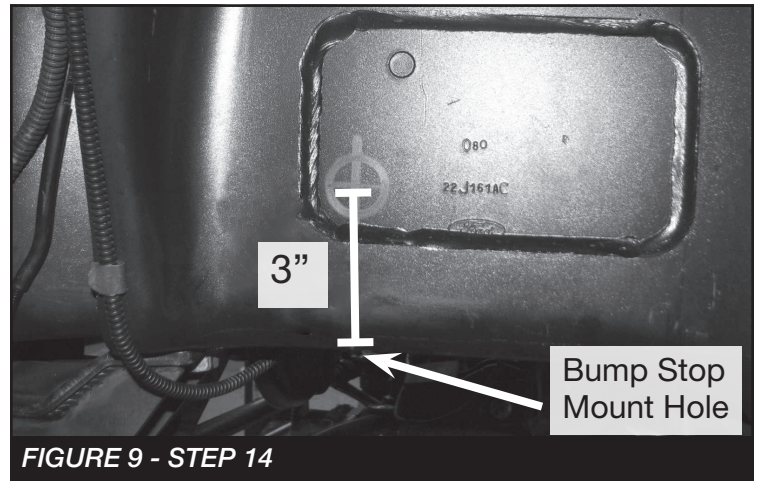
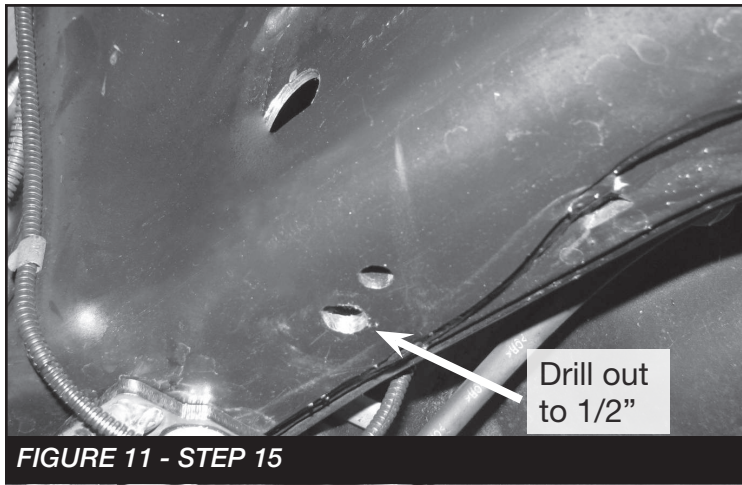


FIGURE 9 - STEP 14

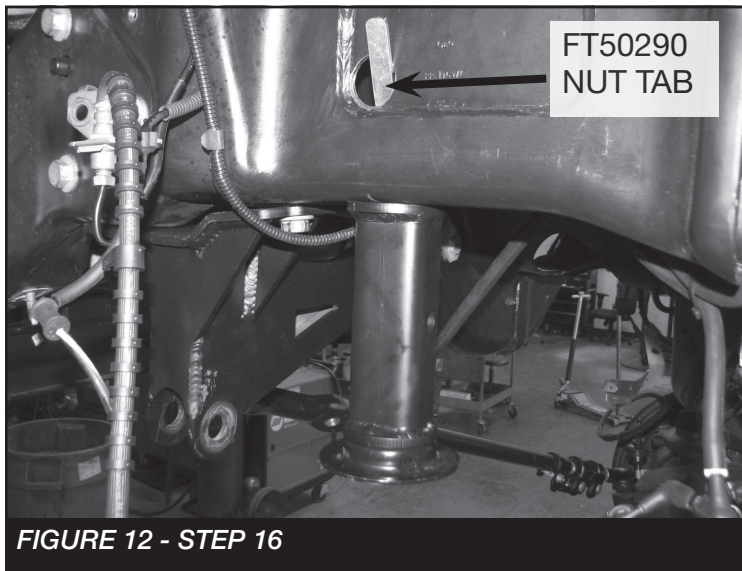


FIGURE 10 - STEP 14

15. Drill out the factory bump stop mount hole to 1/2". **SEE FIGURE 11**

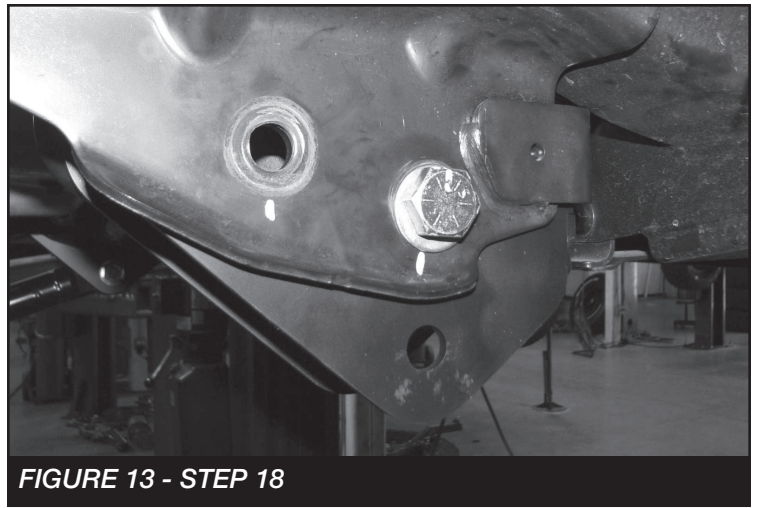


16. Using FT50290 (Nut Tab) and 1/2 X 1-1/2" bolt and washer. Mount the new bump stop extension to the frame. Route the Nut tab through the 1-1/4" hole that was made in Step 11. Torque to 127 ft-lbs. **SEE FIGURE 12**

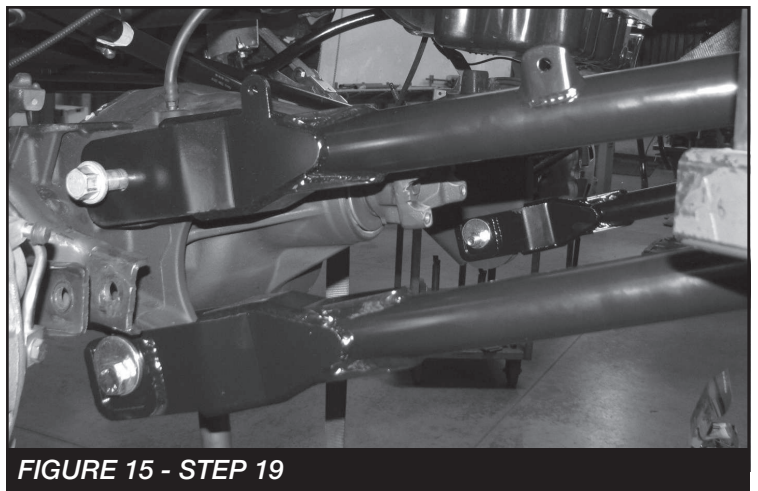
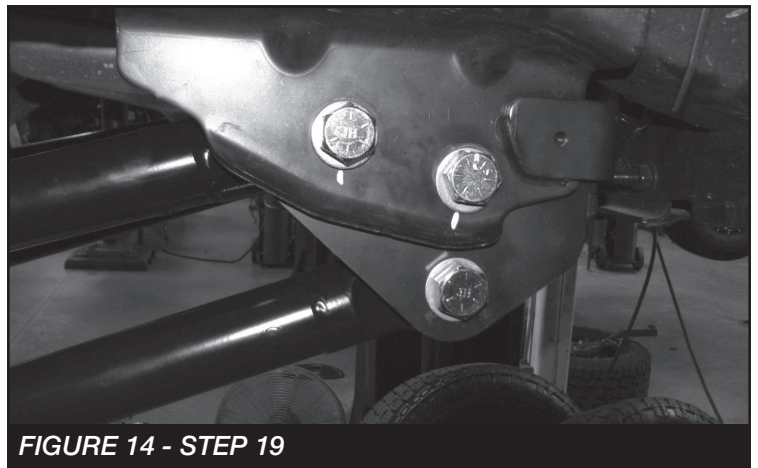


REPEAT BUMP STOP INSTALLATION ON PASSENGER SIDE

17. With the front axle still supported by the floor jack, remove the Driver side factory radius arm.
18. Locate FT30650 (4-Link pocket). Install the bracket into the factory radius arm pocket using the supplied 3/4" x 1-1/2" bolts, nuts and washers through the original rear holes in the frame. Leave loose. **SEE FIGURE 13**



19. Locate FT30129BK (Lower Link) and (2) FT147 (Misalignments). Install the link into the new bracket "lower hole" using the supplied 3/4" X 5" Hardware. Install the FT292 (Alignment Cam kit) hardware at the axle side. Locate FT30692 (Upper Link) and (2) FT147 (Misalignments). Install the link into the new bracket forward upper hole" using the supplied 3/4" X 5" Hardware. Use the factory hardware at the axle mount. Torque 3/4" hardware to 450 ft-lbs, and factory axle bolts/alignment cams to 300 ft-lbs. **SEE FIGURES 14-15**



- **REPEAT STEPS 17-19 ON PASSENGER SIDE**

- **IF INSTALLING A COILOVER CONVERSION KIT, DO SO NOW THEN SKIP TO STEP 22**

20. Install FT30123BK (Coil Spring) using the factory upper isolator. **SEE FIGURE 16**

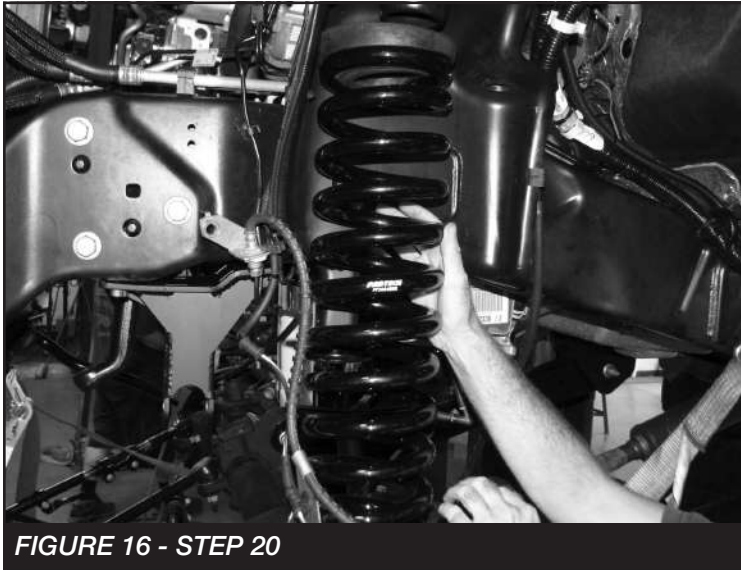


FIGURE 16 - STEP 20

21. Install the new front shocks FTS7188, FTS6188 or FTS810382 with the supplied bushing kits. Using the factory hardware. **NOTE: Install a supplied 9/16" washer at the lower mount to fill up the gap between the bushing and mount.** Due to vehicle variances the top of the lower shock mount may need to be sanded down to clear the shock body only if installing Stealth shocks. **SEE FIGURE ON LAST PAGE.**

22. Reinstall the track bar to the new frame bracket. Torque to 300 ft-lbs. Install the drag link to the new Fabtech pitman arm using the factory hardware and the new supplied cotter pin. **NOTE: The drag link will need to be rotated 180 degrees and installed from the bottom side of the pitman arm. SEE FIGURE 17**



FIGURE 17 - STEP 22

23. **(DRIVER SIDE)** Install FT30660 (Brake line bracket) to the factory brake line tab using the supplied 3/8" hardware. Next, install the bracket to the frame using the factory hardware. Torque hardware to 52 ft-lbs. **SEE FIGURE 18**



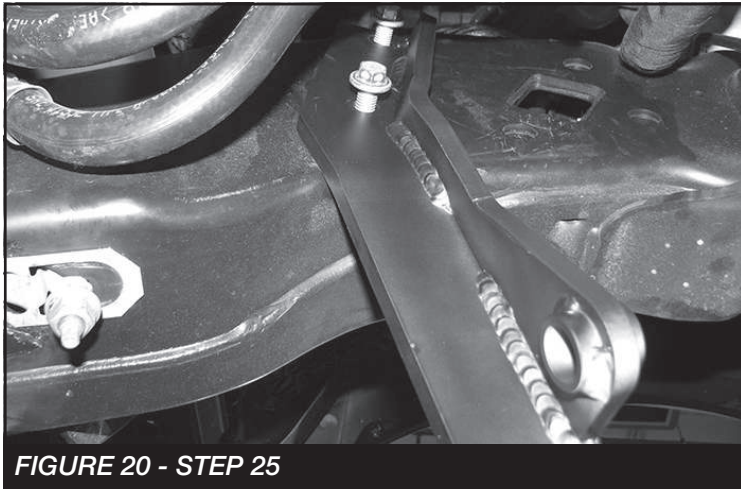
FIGURE 18 - STEP 23

24. **(PASSENGER SIDE)** Install FT30660 (Brake line bracket) to the factory brake line tab using the supplied 3/8" hardware (Use lower hole). Next, using the supplied rubber clamp and 1/4" hardware, attach the ABS line to the upper hole on the FT30660 bracket. Re attach to the frame using the factory hardware. Torque 3/8" & factory hardware to 52 ft-lbs. Torque 1/4" hardware to 14 ft-lbs. **SEE FIGURE 19**

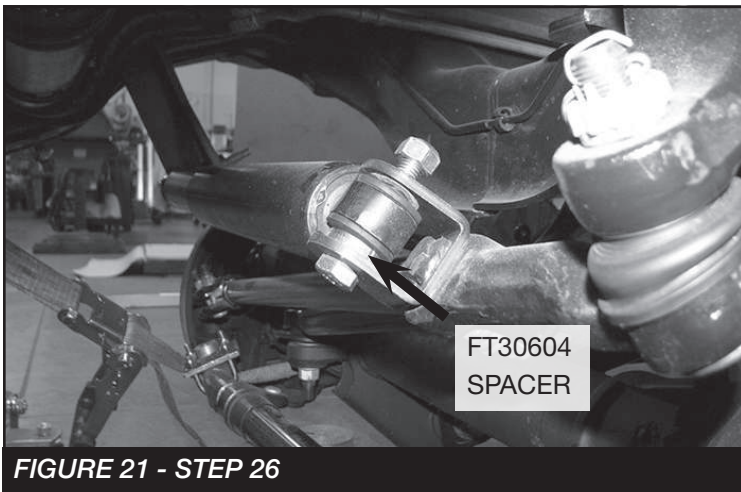


FIGURE 19 - STEP 24

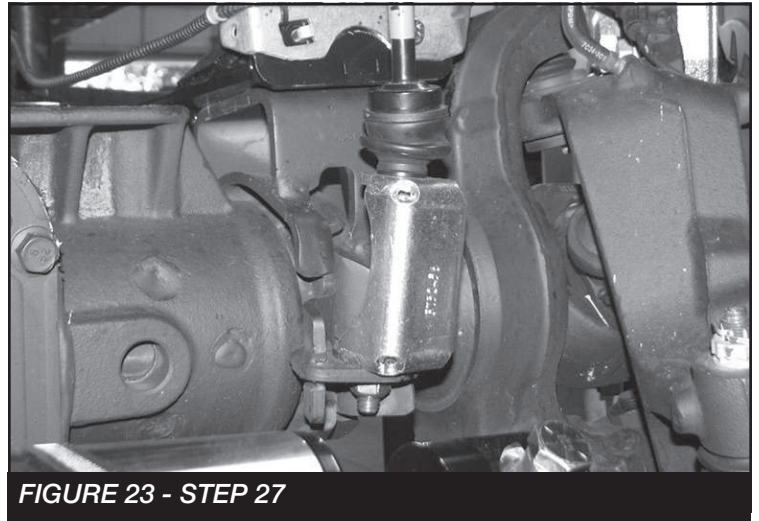
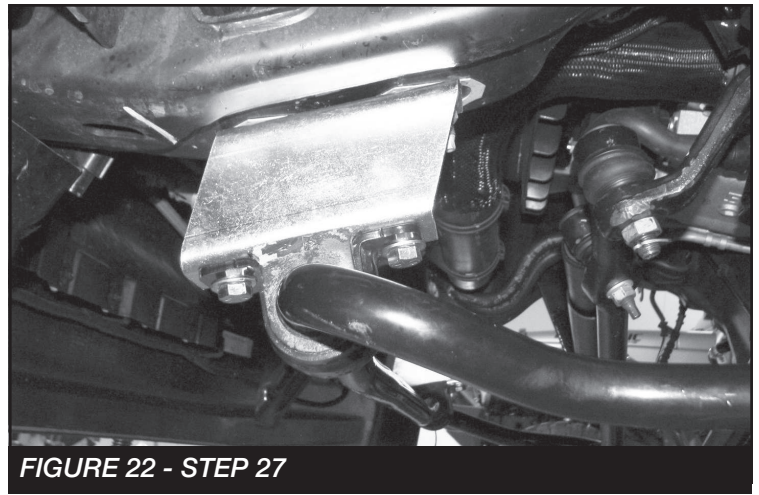
25. Install FT30672 (steering stabilizer drop bracket) in the factory location using the factory hardware. Torque to 127 ft-lbs. **SEE FIGURE 20**



26. Install FT30686 (Stabilizer Clevis) on the factory steering stabilizer using the supplied M12 hardware. **NOTE: Install FT30604 (spacer) like shown in the figure below.** Install the stabilizer using the supplied 9/16" washer and nut to the drag link. Using the factory hardware install the tapered end into the new Fabtech bracket. Torque to 127 ft-lbs. **SEE FIGURE 21**



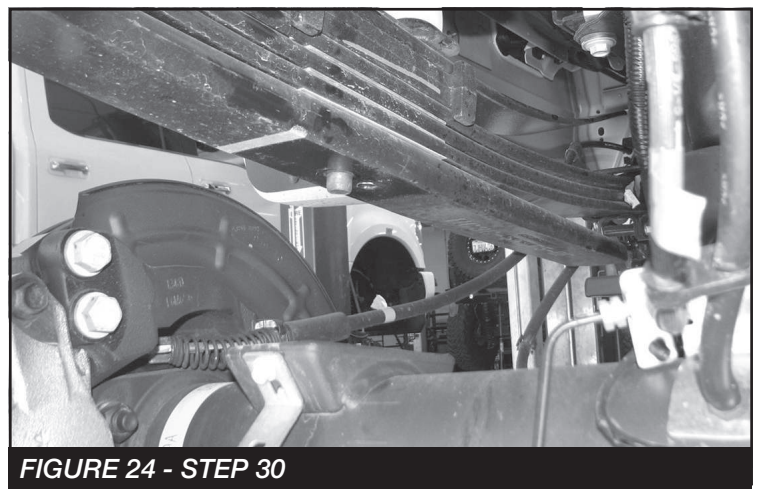
27. Install FT3400-112P (Driver) & FT3400-112D (Passenger) Sway bar drop brackets using the factory hardware. Reinstall the front sway bar to the end links using the supplied 7/16" hardware torque all hardware to 83 ft-lbs. Reconnect the sway bar to the end links. Torque to 52 ft-lbs. Remove the factory end links and install FT30456 to the axle using the supplied 1/2-13 X 1-1/2" hardware then reinstall the endlink to the new bracket and sway bar. **SEE FIGURES 21-22**



28. Install the lower brake line bracket to the lower spring perch using the factory hardware. Torque to 29 ft-lbs.
29. Install the front tires and wheels. Torque lug nuts to wheel manufacturer's specifications.

REAR SUSPENSION

30. Jack up the rear end of the vehicle and support the frame rails with jack stands. Release the parking brake at this time. Supporting the rear differential, remove the rear shock and u-bolts. Disconnect the sway bar end link from the sway bar then lower axle down and remove the blocks. Use care not to over extend the brake hose. **SEE FIGURE 24**



31. Install the new FTBK65 (Block) onto the axle. Jack up the rear axle so the block is seated in with the spring pin. Next, install the FT759U ubolts. Torque to 275 ft-lbs in a diagonal pattern.

32. Remove the sway bar end link and factory bracket from the frame. Save hardware. Remove end link from the bracket and discard. The bracket will be re-used. **SEE FIGURE 25**

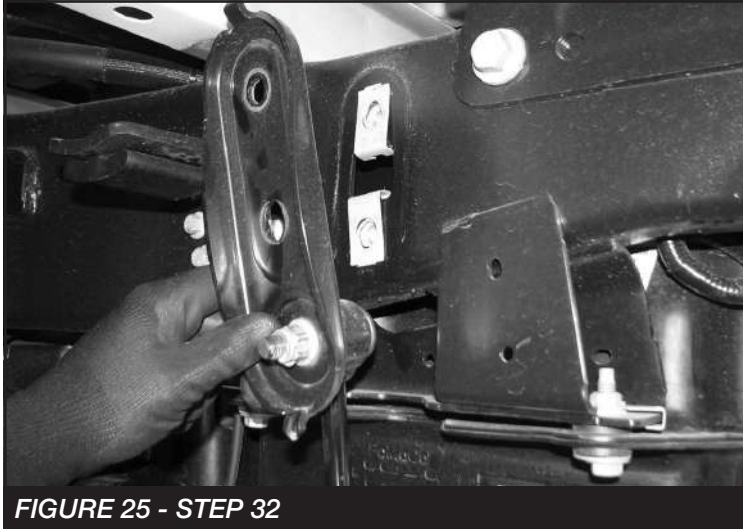


FIGURE 25 - STEP 32

33. Remove the factory bump stop from the frame and separate the bumpstop from the mounting plate. Install FT30750 (Bumpstop Extension) onto the bumpstop using the factory nut. **Note: The alignment tab will seat into the hole on the new bracket. SEE FIGURE 26**



FIGURE 26 - STEP 33

34. Using a 1/2" drill bit. Drill out the center hole on the factory bumpstop mounting plate. **SEE FIGURE 27**



FIGURE 27 - STEP 34

35. Using the supplied 1/2" X 1-1/4" hardware. Install the mounting plate to the bumpstop assembly. **NOTE: Make sure the orientation is in line as shown in FIGURE 28.** Torque hardware to 127 ft-lbs.



FIGURE 28 - STEP 35

36. Install the bumpstop assembly into the vehicle using the factory hardware. Torque to 100 ft-lbs. **SEE FIGURE 29**



FIGURE 29 - STEP 36

37. Install the FT1004 (Bushings) and FT50089 (Sleeves) into both FT30784 (End Links). Install the new end links to the factory brackets using the supplied 1/2" X 2-1/2" hardware. **NOTE: Install the bolt from the back side. SEE FIGURE 30** Install the brackets/Tie rods to the frame and sway bar using the factory hardware for the frame mount and the supplied 1/2 X 2-1/2" hardware at the sway bar location. Torque to 127 ft-lbs. **SEE FIGURE 31**

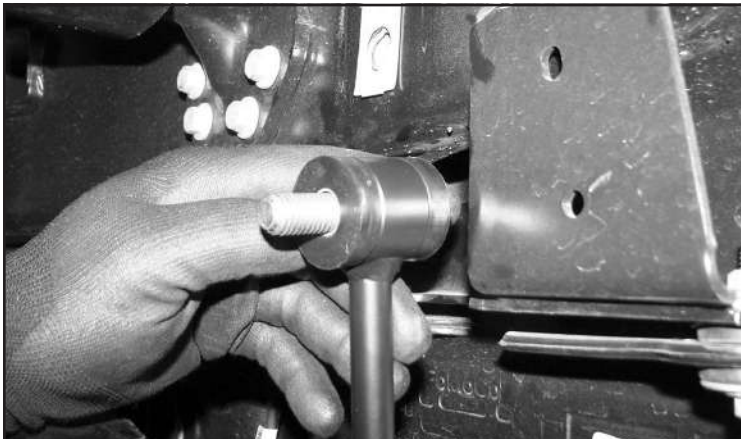


FIGURE 30 - STEP 37

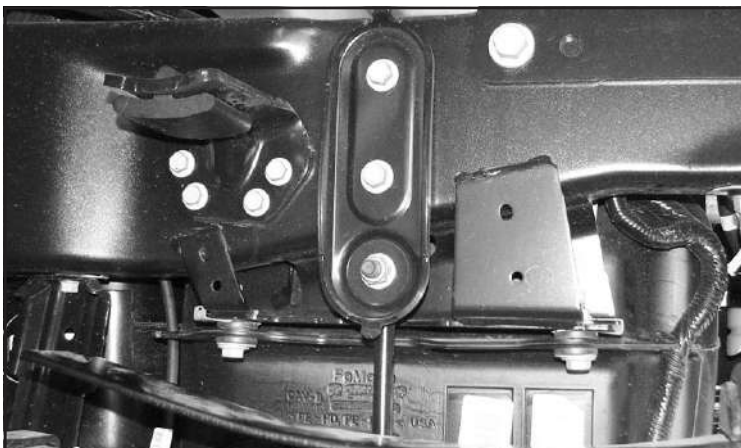


FIGURE 31 - STEP 37

38. Install the new rear shocks FTS7266, FTS6063 or DL FTS810052 using the factory hardware, torque to 90 ft-lbs. **SEE FIGURE 32**

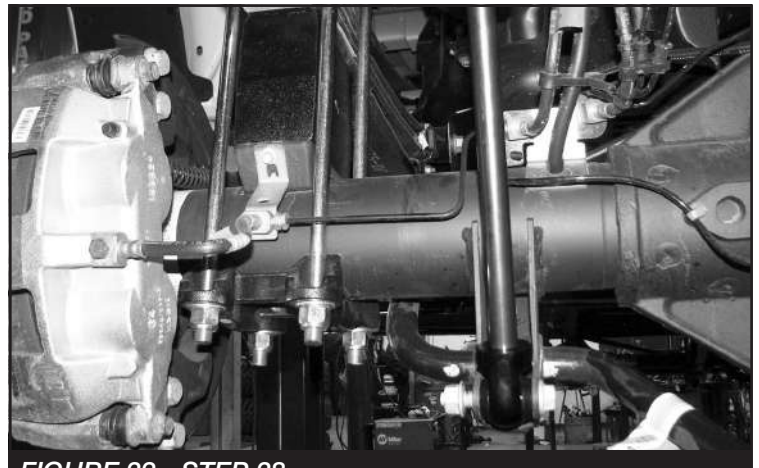


FIGURE 32 - STEP 38

39. Install tires and wheels and torque lug nuts to wheel manufacturer's specifications. Turn front tires left to right and check for appropriate tire clearance. **Note - Some oversized tires may require trimming of the front bumper & valance.**
40. Check front end alignment and set to factory specifications. Readjust headlights.
41. Recheck all bolts for proper torque.
42. Recheck brake hoses, ABS wires and suspension parts for proper tire clearance while turning tires fully left to right.
43. Check the fluid in the front and rear differential and fill if needed with factory specification differential oil. **Note - some differentials may expel fluid after filling and driving. This can be normal in resetting the fluid level with the new position of the differential/s.**
44. Install Driver Warning Decal. Complete product registration card and mail to Fabtech in order to receive future safety and technical bulletins on this suspension.

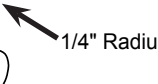
Vehicles that will receive oversized tires should check ball joints, uniballs and all steering components every 2500-5000 miles for wear and replace as required.

RE-TORQUE ALL NUTS, BOLTS AND LUGS AFTER 50 MILES AND PERIODICALLY THEREAFTER.

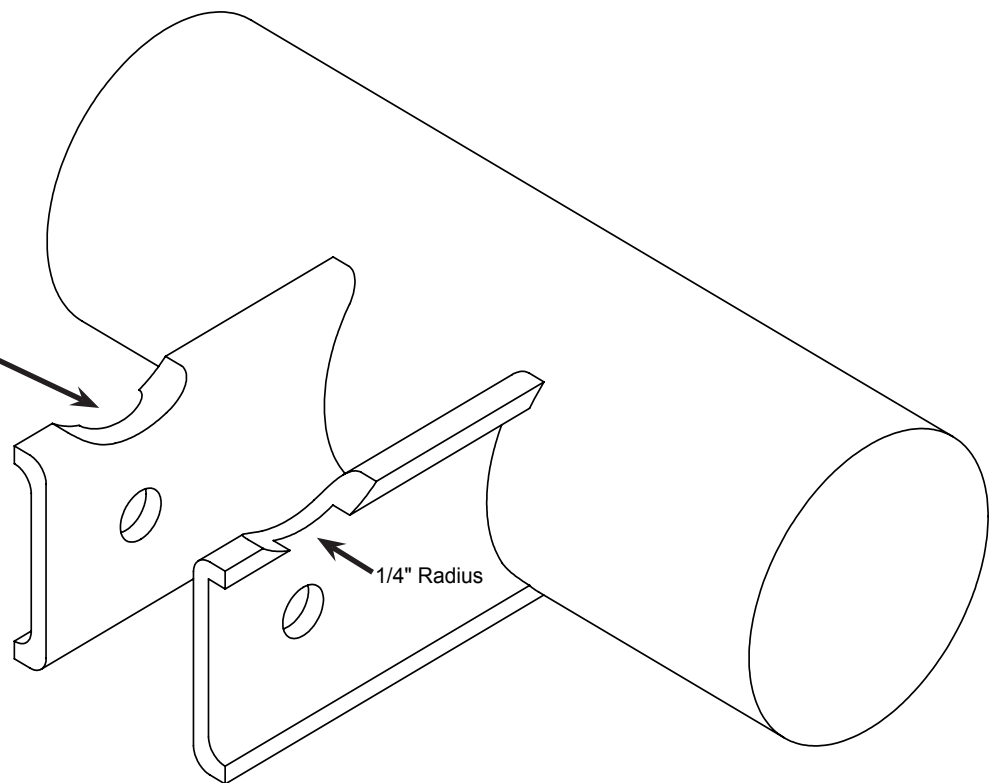
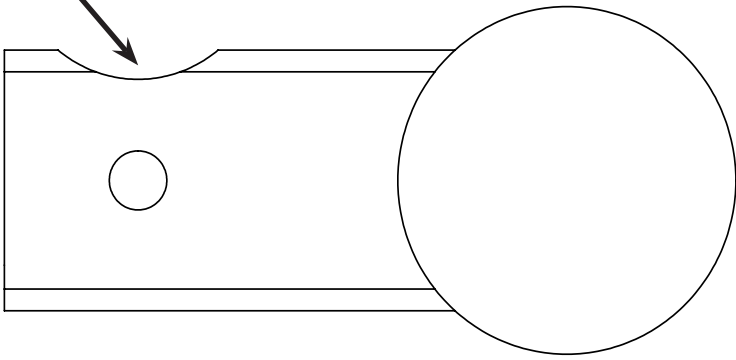
1/4" Radius



1/4" Radius



1/4" Radius





INSTALLATION INSTRUCTIONS

2011-16 FORD SUPERDUTY 4.0 COILOVER		
1	FTS835234D FTS835235D FTS835236D	4.0 COILOVER W/ RESI (DRIVER)
1	FT30763	LOWER COILOVER MOUNT (DRIVER)
1	FT30726	UPPER COILOVER MOUNT (DRIVER)
1	FT30728	DRILL GUIDE
1	FT835234i	INSTRUCTIONS
1	FT86088	HARDWARE KIT
1	FT86089	HARDWARE KIT 89
1	FT30654	BUMP STOP EXTENSION

2011-16 FORD SUPERDUTY 4.0 COILOVER		
1	FTS835234P FTS835235P FTS835236P	4.0 COILOVER W/ RESI (PASSENGER)
1	FT30764	LOWER COILOVER MOUNT (PASSENGER)
1	FT30727	UPPER COILOVER MOUNT (PASSENGER)
1	FT30728	DRILL GUIDE
1	FT835234i	INSTRUCTIONS
1	FT86077	HARDWARE KIT 77
1	FT86088	HARDWARE KIT 88
1	FT30654	BUMP STOP EXTENSION

FT86089 HARDWARE KIT 89		
1	FT83245	UPPER MOUNT BUSHING (LARGE)
1	FT83246	UPPER SHOCK BUSHING (SMALL)
2	FT83474	SPACER (UPPER)
2	FT83475	5/8" SPACER (LOWER)
2	FT89016	HOSE CLAMP
2	FT30774	ABS MODULE SPACER

FT86077 HARDWARE KIT 77		
1	FT83245	UPPER MOUNT BUSHING (LARGE)
1	FT83246	UPPER SHOCK BUSHING (SMALL)
2	FT83474	SPACER (UPPER)
2	FT83475	5/8" SPACER (LOWER)
2	FT89016	HOSE CLAMP

FT86088 - HARDWARE KIT		LOCATION
1	M14-2.0 X 30MM HEX BOLT	LOWER MOUNT
1	M14 FLAT WASHER	
3	7/16" USS FLAT WASHER	UPPER MOUNT
3	7/16-14 C-LOCK NUT	
4	1/2" SAE WASHER	
2	1/2-13 C-LOCK NUT	
1	1/2-13 X 1-1/2" HEX BOLT	
1	1/2-13 X 2-1/2" HEX BOLT	
2	5/8" SAE WASHER	
1	5/8-11 C-LOCK NUT	
1	5/8-11 X 3-1/2" HEX BOLT	
3	1/4-20 X 1" HEX BOLT	BRAKE LINE
6	1/4" SAE WASHER	
3	1/4-20 NYLOCK NUT	
1	THREAD LOCKING COMPOUND	

2011-16 FORD F-250/F-350 SUPERDUTY 4.0 COILOVER CONVERSION KIT FOR 6" & 8" KITS

FT835234i



- TOOL LIST -

Required Tools (Not Included)

-Basic Hand Tools
-Floor Jack
-Jack Stands

-Torque Wrench
-Die Grinder w/ Cutoff Wheel or Sawzall
-Assorted Metric and S.A.E sockets, and Allen wrenches

- PRE-INSTALLATION NOTES -

READ THIS BEFORE YOU BEGIN INSTALLATION -

Check all parts to the parts list above before beginning installation.

Read all instructions thoroughly from start to finish before beginning the installation. If these instructions are not properly followed severe frame, driveline and / or suspension damage may occur.

Check your local city and state laws prior to the installation of this system for legality. Do not install if not legal in your area.

Prior to the installation of this suspension system perform a front end alignment and record. Do not install this system if the vehicle alignment is not within factory specifications. Check for frame and suspension damage prior to installation.

The installation of this suspension system should be performed by two professional mechanics.

This suspension must be installed with Fabtech shock absorbers.

Use the provided thread locking compound on all hardware.

WARNING- Installation of this system will alter the center of gravity of the vehicle and may increase roll over as compared to stock.

Vehicles that receive oversized tires should check ball joints, uniballs, tie rods ends, pitman arm and idler arm every 2500-5000 miles for wear and replace as needed.

Verify differential fluid is at manufactures recommended level prior to kit installation. Installation of the kit will reposition the differential and the fill plug hole may be in a different position. (For example, if the manufacture recommends 3 quarts of fluid, make sure the diff has 3 quarts of fluid). Check your specific manual for correct amount of fluid.

FOOTNOTES -

- WILL NOT WORK WITH LEVELING OR BASIC SYSTEM

NOTE: TO ORDER WEARABLE REPLACEMENT COMPONENTS DO NOT USE PART NUMBERS SHOWN ON THIS INSTRUCTION SHEET. GO TO FABTECH WEBSITE AND LOOK UP WEARABLE REPLACEMENT PARTS TO FIND THE PROPER PART NUMBER TO ORDER.

- INSTRUCTIONS -

1. Disconnect the negative terminal on the battery. Jack up the front end of the truck and support the frame rails with jack stands. **NEVER WORK UNDER AN UNSUPPORTED VEHICLE!** Remove the front tires.
2. Disconnect the sway bar from the end links and the factory brake line bracket from the lower coil spring perch. **SEE FIGURE 1.** Repeat on Passenger side.

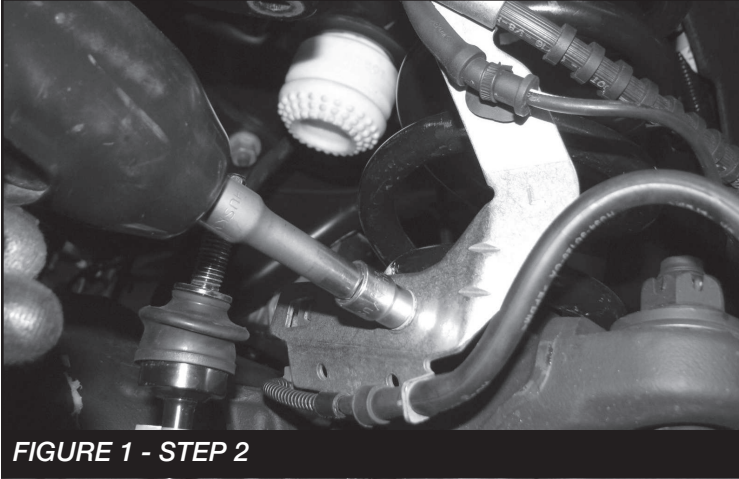


FIGURE 1 - STEP 2

3. Disconnect the track bar from the track bar bracket. Save hardware.
4. Remove and discard the front shocks, coil springs and upper rubber isolators from both sides. Save lower shock hardware.
5. Remove the lower coil spring perch from the axle and discard. Repeat on passenger side.
6. **(DRIVER SIDE ONLY)** Remove the driver side inner fender liner. Locate the ABS module mounted to the backside of the factory upper spring perch. Remove the two nuts attaching the vertical and horizontal brackets together. Separate the two. **SEE FIGURE 2**

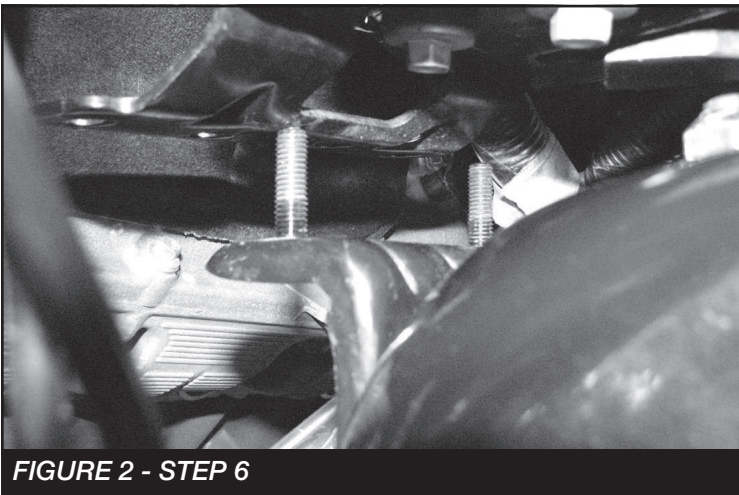


FIGURE 2 - STEP 6

7. Locate and install the two FT30774 (ABS Module Spacer) onto the two studs then re-attach the two brackets together using the factory nuts. **SEE FIGURE 3-4**

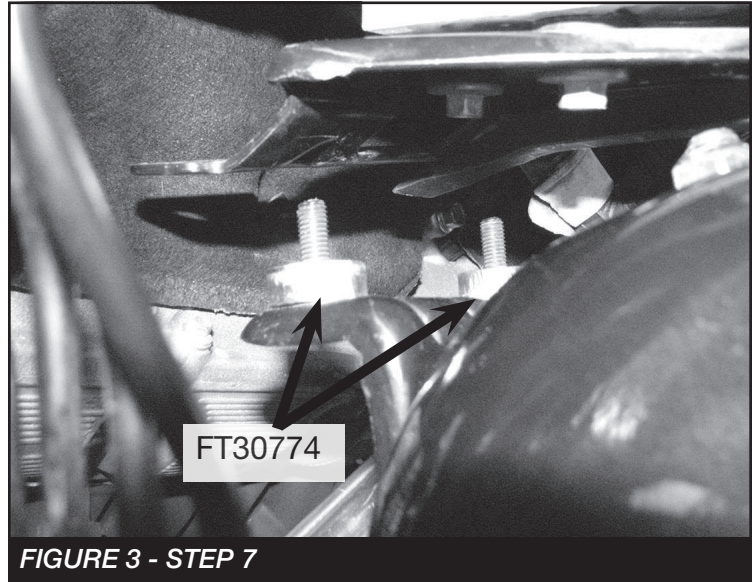


FIGURE 3 - STEP 7

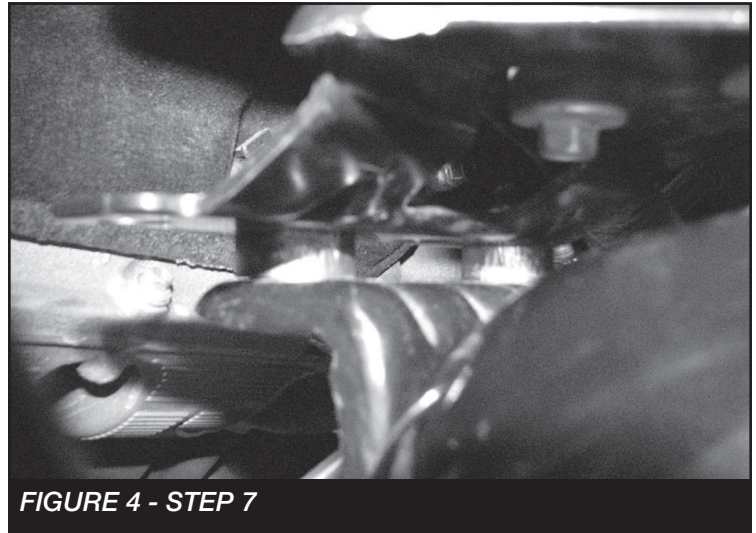
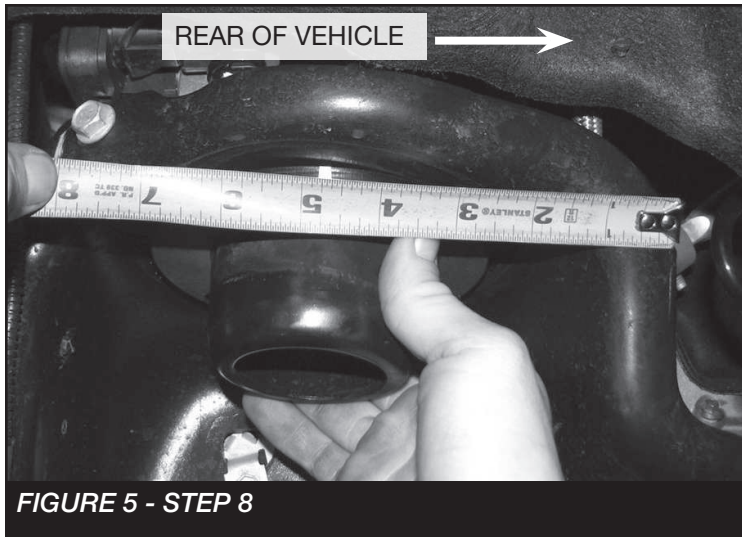
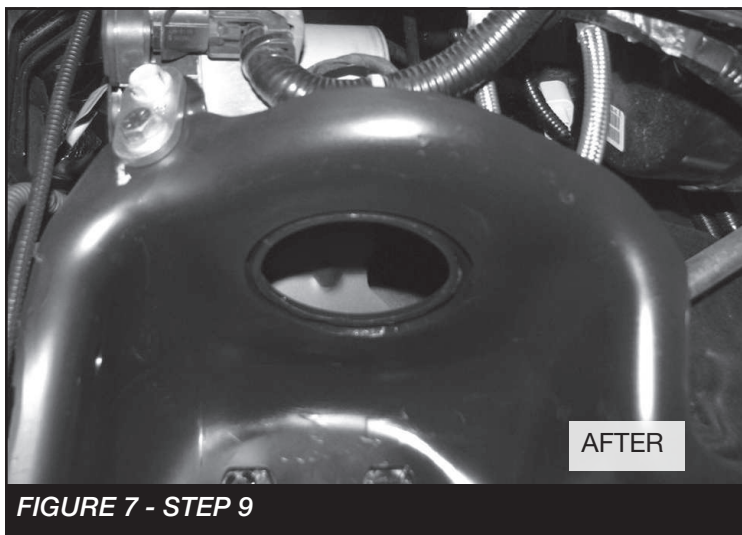
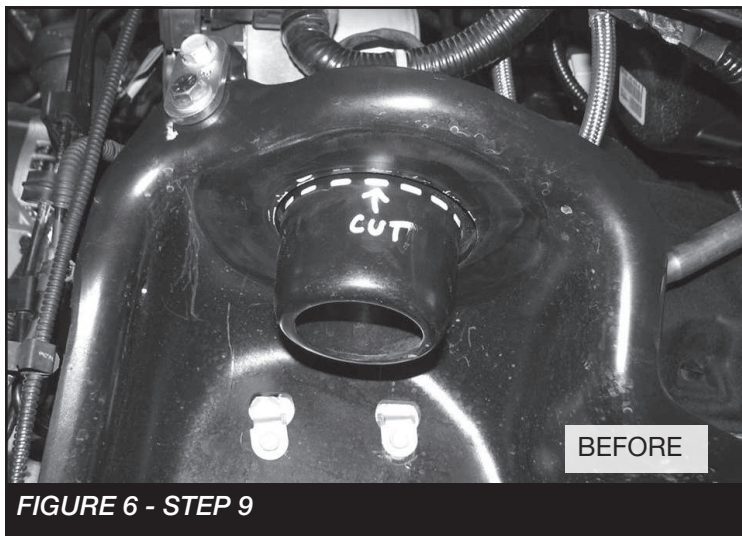


FIGURE 4 - STEP 7

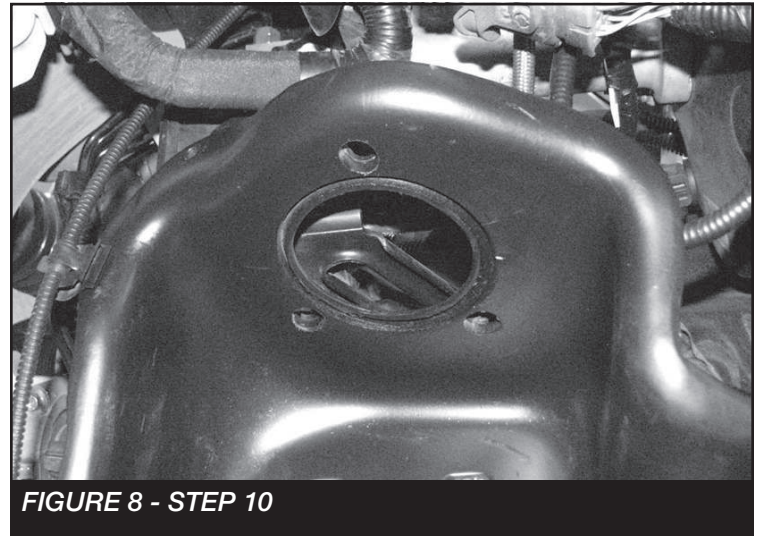
8. Locate FT30728 (Drill guide). Place the guide up in the upper coil spring mount with the notch facing towards you. Measure 4-3/4" from the edge of the mount. Place the notch at the 4-3/4" mark. Next, mark the 3 holes and remove the guide. **SEE FIGURES 5**



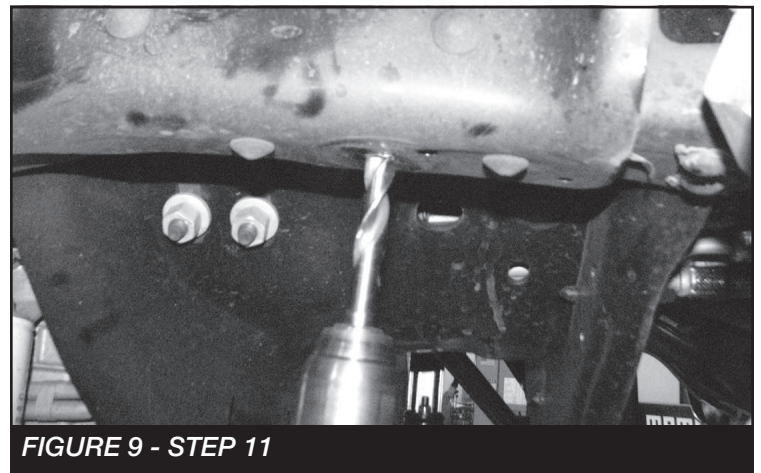
9. Locate the upper coil spring perch. The locator tube will need to be cut off using a reciprocating saw or cut off wheel. Sand to a smooth finish. **SEE FIGURES 6-7**



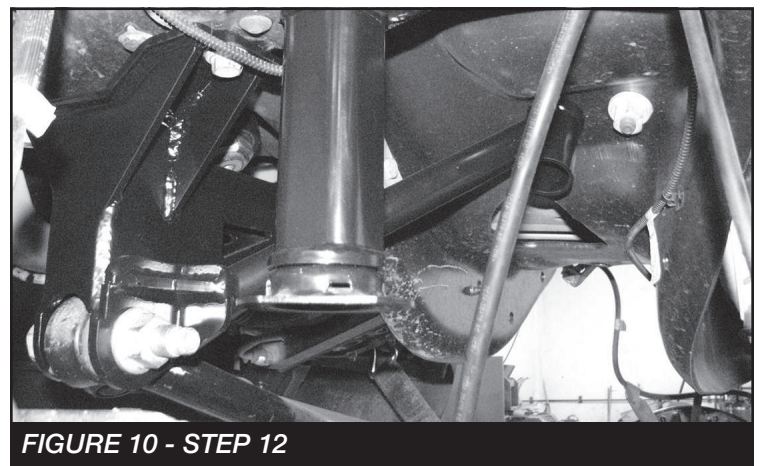
10. Using a drill and a 1/2" drill bit. Drill the 3 holes that were previously marked in step 9. Paint all bare areas. **SEE FIGURE 8**



11. Remove the existing bumpstop or bumpstop extension from the frame. Drill the factory hole in the frame to 1/2" **SEE FIGURE 9**



12. Using the factory hardware mount the factory bumpstop to FT30654 (Bumpstop Ext). Next install to the frame using the supplied 1/2" hardware. **NOTE: Sanding the factory bumpstop plate to clear the coilover may be necessary. SEE FIGURE 10**



13. REPEAT STEPS 8-12 ON PASSENGER SIDE

14. Locate the new Driver Coilover, FT30726 (Driver upper coilover mount), FT83245 (large bushing, FT83246 (small bushing), two of the FT83474 (1/2" ID misalignment) 1/2" X 2-1/2" bolt and hardware. Using **FIGURE 11** install the upper mount on the coilover with the misalignments and bushings. **NOTE: The resi hose will orientate towards the rear of the vehicle and the 1/2" bolt will needs to be installed from the back side.** Torque to 127 ft-lbs. Once complete set aside.

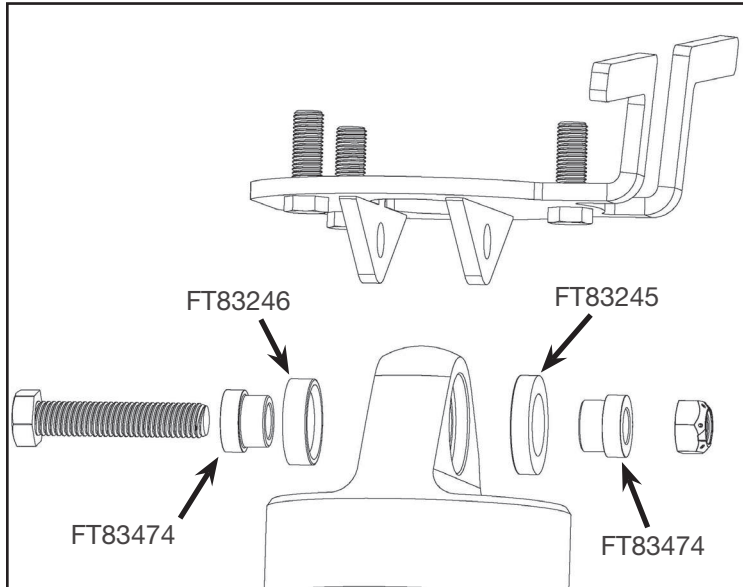


FIGURE 11 - STEP 14

15. REPEAT STEP 14 FOR THE PASSENGER SIDE.

Use Passenger Coilover, FT30727 (pass upper mount) bushings, misalignments and 1/2" hardware. **SEE FIGURE 12 FOR COMPLETED ASSEMBLY.**

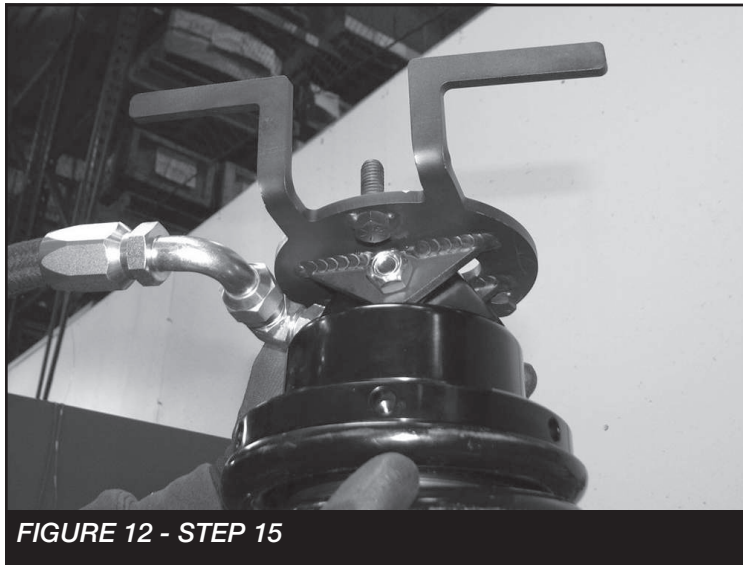


FIGURE 12 - STEP 15

16. Install FT30763 (Driver lower coilover mount) onto the driver side of the axle using the factory shock hardware at the factory shock location and M14 X 30mm bolt and washer at the lower spring perch location. Torque factory hardware to 100 ft-lbs and M14 to 160 ft-lbs. **SEE FIGURE 13-14**

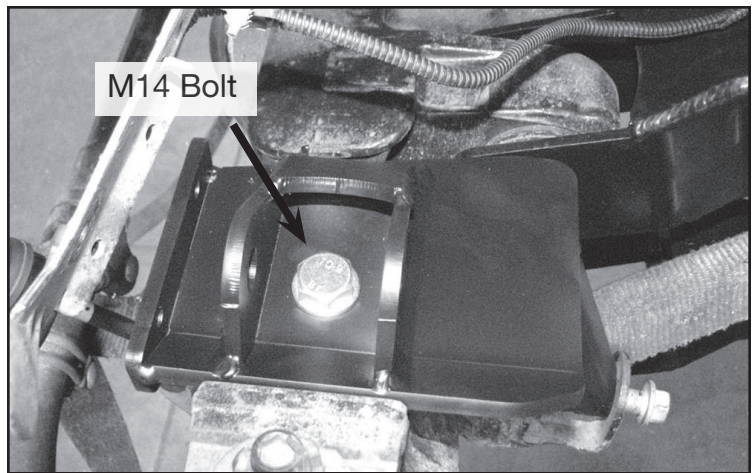


FIGURE 13 - STEP 16

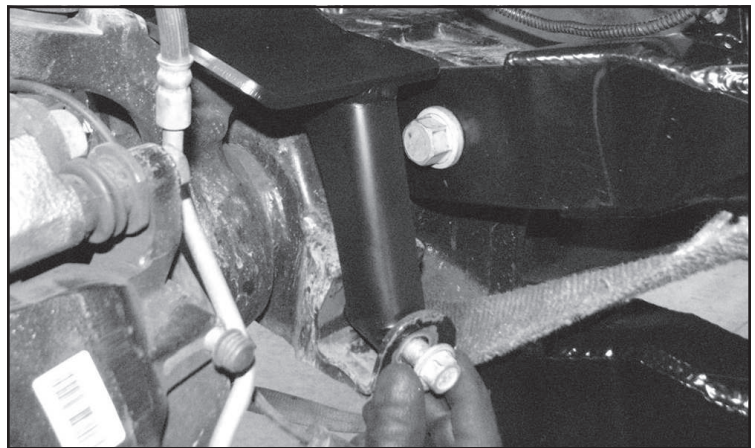


FIGURE 14 - STEP 16

17. REPEAT STEP 16 ON THE PASSENGER SIDE USING PASSENGER LOWER COILOVER MOUNT.

18. Install the driver side coilover mount using the supplied 7/16" nuts and washers for the upper mount and the 5/8" hardware with two FT83475 (Misalignments) at the lower mount. Torque 7/16" to 83 ft-lbs and 5/8" 254 ft-lbs. **SEE FIGURE 15-17**

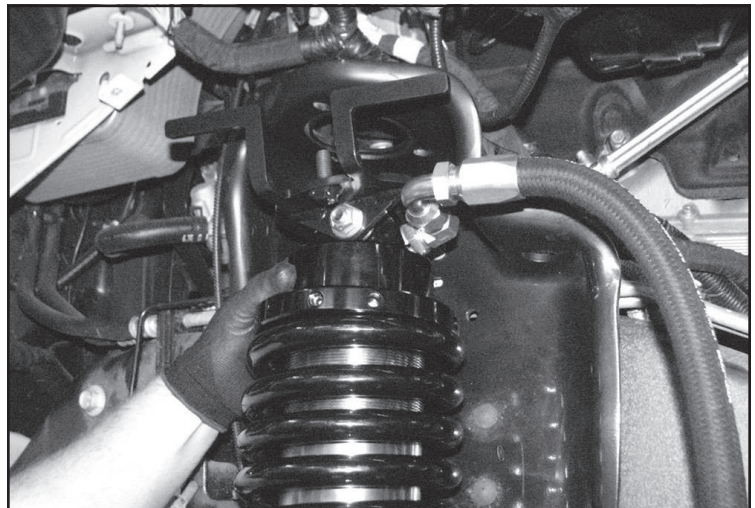


FIGURE 15 - STEP 18

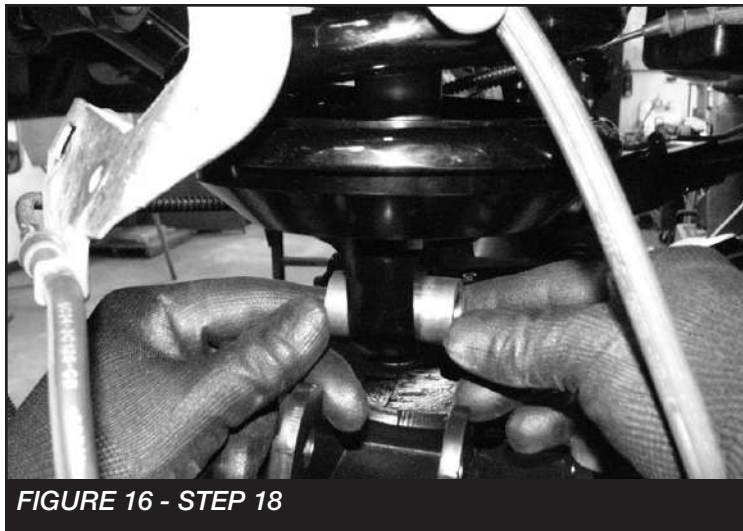


FIGURE 16 - STEP 18



FIGURE 17 - STEP 18

19. Re-install the inner fender liners.
20. Install the resi can to the resi mount using the supplied clamps. **SEE FIGURE 18**



FIGURE 18 - STEP 20

21. REPEAT STEPS ON THE PASSENGER SIDE

22. Install the factory brake line bracket to the new lower coilover mount using the supplied 1/4" hardware. Torque to 14 ft-lbs.
23. Reconnect the sway bar end links to the sway bar and track bar. Torque the track bar bracket bolt to 160 ft-lbs.
24. Install tires and wheels and torque lug nuts to wheel manufacturer's specifications. Turn front tires left to right and check for appropriate tire clearance. **Note - Some oversized tires may require trimming of the front bumper & valance.**
25. Check front end alignment and set to factory specifications. Readjust headlights.
26. Recheck all bolts for proper torque.
27. Recheck brake hoses, ABS wires and suspension parts for proper tire clearance while turning tires fully left to right.
28. Check the fluid in the front and rear differential and fill if needed with factory specification differential oil. **Note - some differentials may expel fluid after filling and driving. This can be normal in resetting the fluid level with the new position of the differential/s.**
29. Install Driver Warning Decal. Complete product registration card and mail to Fabtech in order to receive future safety and technical bulletins on this suspension.

Vehicles that will receive oversized tires should check ball joints, uniballs and all steering components every 2500-5000 miles for wear and replace as required.

RE-TORQUE ALL NUTS, BOLTS AND LUGS AFTER 50 MILES AND PERIODICALLY THEREAFTER.