



INSTALLATION INSTRUCTIONS



2013-2017 DODGE 3500 4WD 7" RADIUS ARM KIT W/ COILS

FTS23168 w/ PERFORMANCE SHOCKS

FTS23169 w/ STEALTH SHOCKS

FTS23170 w/ DIRT LOGIC SHOCKS

FT23168i

- PARTS LIST -

FTS23104		7" RADIUS ARM KIT W/ COILS
2	FT44232BK	RADIUS ARM DROP
1	FT44315BK	TRACK BAR BRACKET
1	FT44230BK	RADIUS ARM (DRIVER)
1	FT44231BK	RADIUS ARM (PASSENGER)
1	FT44404BK	LOWER SPRING PERCH (DRIVER)
1	FT44405BK	LOWER SPRING PERCH (PASSENGER)
2	FT44320BK	FRONT COIL SPRING
1	FT44402BK	BUMP STOP MOUNT (DRIVER)
1	FT44403BK	BUMP STOP MOUNT (PASS)
1	FT44043	SWAY BAR DROP (DRIVER)
1	FT44044	SWAY BAR DROP (PASSENGER)

FTS23168		COMPONENT BOX 2 W/PERFORMANCE SHOCKS
1	FT44172	DODGE PITMAN ARM
2	FT44412BK	REAR BUMP STOP SPACER
1	FT44413	HARDWARE KIT
2	FT44356BK	COIL RETAINER
1	FT44396	HARDWARE SUBASSEMBLY
4	FT748U	UBOLT RD 9/16-18 X 15.00 X 4.00
2	FTBK4	BLOCK 4.0"
1	FTS419	4WD DRIVESHAFT SHIM KIT
2	FTS7346	PERFORMANCE SHOCK FRONT
2	FTS7266	PERFORMANCE SHOCK REAR

FTS23169		COMPONENT BOX 2 W/STEALTH SHOCKS
1	FT44172	DODGE PITMAN ARM
2	FT44412BK	REAR BUMP STOP SPACER
1	FT44413	HARDWARE KIT
2	FT44356BK	COIL RETAINER
1	FT44396	HARDWARE SUBASSEMBLY
4	FT748U	UBOLT RD 9/16-18 X 15.00 X 4.00
2	FTBK4	BLOCK 4.0"
1	FTS419	4WD DRIVESHAFT SHIM KIT
2	FTS6346	STEALTH SHOCK FRONT
2	FTS6063	STEALTH SHOCK REAR

FTS23170		COMPONENT BOX 2 W/DIRT LOGIC SHOCKS
1	FT44172	DODGE PITMAN ARM
2	FT44412BK	REAR BUMP STOP SPACER
1	FT44413	HARDWARE KIT
2	FT44356BK	COIL RETAINER
1	FT44397	HARDWARE SUBASSEMBLY
4	FT748U	UBOLT RD 9/16-18 X 15.00 X 4.00
2	FTBK4	BLOCK 4.0"
1	FTS419	4WD DRIVESHAFT SHIM KIT
2	FT801072	2.25 DLSS W/RESI
2	FT811192	2.25 DLSS N/R

FT44413 - HARDWARE KIT		LOCATION
BAG 1		
1	M18-2.5 X 90MM HEX BOLT	TRACK BAR DROP BRACKET
2	M18 WASHERS	
1	NUT C-LOCK 18MM G10.9 ZINC	
2	1/2-13 X 1-1/2 HEX BOLT G8	TRACK BAR DROP BRACKET
2	1/2-13 X 4" HEX BOLT G8	
8	1/2 SAE WASHER G8	
4	1/2-13 C-LOCK NUT	
2	5/16-18 X 2-1/2 HEX BOLT G8 ZINC	BUMP STOP
4	5/16 SAE WASHER G8 ZINC	
2	5/16-18 C-LOCK NUT ZINC	
4	1/4-20 X 1 HEX BOLT G5	BRAKE LINE BRACKET
2	1/4 SAE WASHERG5	
2	1/4-20 C-LOCK NUT	
4	5/16-18 X 1-1/2 HEX BOLT	COIL SPACER
6	5/16 SAE FLAT WASHER	
2	5/16-18 C-LOCK NUT ZINC	
BAG 2		
2	M18-2.5 X 120MM HEX BOLT	RADIUS ARM POCKET
4	M18 WASHERS	
2	NUT C-LOCK 18MM G10.9 ZINC	
12	1/2-13 X 1-1/4 HEX BOLT G8 ZNC	RADIUS ARM POCKET/BUMP STOP
24	1/2 SAE WASHER G8 ZINC	
12	1/2-13 C-LOCK NUT ZINC	
4	7/16-14 X 1-1/4 HEX BOLT	SWAY BAR DROP
8	7/16" SAE WASHER	
4	7/16-14 C-LOCK NUT	
BAG 3		
4	7/16-14 X 1-1/4" HEX BOLT G8	REAR BUMP STOP
8	7/16 SAE WASHER G8	
4	7/16-14 C-LOCK NUT	
8	9/16-18 NYLOCK NUT	UBOLTS
8	9/16 SAE FLAT WASHER	
1	5/16-18 X 1 HEX BOLT	BRAKELINE BRACKET REAR
2	5/16" SAE WASHER	
1	5/16-18 C-LOCK NUT	
2	M10-1.5 X 60MM HEX BOLT	CARRIER BEARING DROP
2	10MM WASHER	
2	10MM SPLIT WASHER	
2	THREAD LOCKING COMPOUND	

**- PARTS LIST -
RADIUS ARM KIT CONTINUED**

FT44396		HARDWARE SUBASSEMBLY
2	FT102	SLEEVE 1.000 X .732 X 3.280
2	FT44135	BUMP STOP MOUNT TAB
2	FT44245	BRAKE LINE EXT (FRONT)
4	FT404739	SLEEVE OD 0.62 ID 12MM L.1.48
2	FT44258	1/4 NUT TAB
2	FTS88	BUMPSTOP 1 IN TALL LOW RND
1	FTAS16	DRIVER WARNING DECAL
1	FTAS12	STICKER FT BLUE 10X4
1	FTREGCARD	REGISTRATION CARD
1	FT23168i	INSTRUCTIONS
1	FT44359	COIL RETAINER WASHER
1	FT44239	WASHER 4.250 X .510 X .250
2	FT44317	COIL SPRING SPACER NUT TAB
4	FT1006	BUSHING C1500 L.T. LOWER
1	FT44246	TRAC BAR SUPPORT SPACER
1	FT30496	BRAKE LINE BRACKET (REAR)
2	FT160	BLOCK PIN SLEEVE
2	FT604	SLEEVE 1.000 X .760 X 2.600
2	FT44253	RADIUS ARM DROP NUT TAB

FT44397		HARDWARE SUBASSEMBLY
2	FT102	SLEEVE 1.000 X .732 X 3.280
2	FT44135	BUMP STOP MOUNT TAB
2	FT44245	BRAKE LINE EXT
1	FT44246	TRACK BAR SUPPORT SPACER
2	FT44258	1/4 NUT TAB
2	FTS88	BUMPSTOP 1 IN TALL LOW RND
1	FTAS16	DRIVER WARNING DECAL
1	FTAS12	STICKER FT BLUE 10X4
1	FTREGCARD	REGISTRATION CARD
1	FT23168i	INSTRUCTIONS
2	FTSP01029	HARDWARE PACK STEM BUSHING
2	FT86021	HARDWARE & BUSHING KIT 21
4	FT83077	1.5/1.75-2.25/2.5 RESI CLAMP
4	FT89026	#48 HOSE CLAMP 2-9/16 - 3-1/2
2	FT86008	HARDWARE & BUSHING KIT 8
1	FT44359	COIL RETAINER WASHER
1	FT44239	WASHER 4.250 X .510 X .250
2	FT44317	COIL SPRING SPACER NUT TAB
4	FT1006	BUSHING C1500 L.T. LOWER
1	FT30496	BRAKELINE BRACKET (REAR)
2	FT160	BLOCK PIN SLEEVE
2	FT604	SLEEVE 1.000 X .760 X 2.600
2	FT44253	RADIUS ARM DROP NUT TAB



- TOOL LIST -

Required Tools (Not Included)

Basic Hand Tools
Floor Jack
Jack Stands
Assorted Metric and S.A.E sockets, and Allen wrenches
Torque Wrench
Die Grinder w/ Cutoff Wheel or Sawzall

- PRE-INSTALLATION NOTES -

Read this before you begin installation-

Check all parts to the parts list above before beginning installation.

Read all instructions thoroughly from start to finish before beginning the installation. If these instructions are not properly followed severe frame, driveline and / or suspension damage may occur.

Check your local city and state laws prior to the installation of this system for legality. Do not install if not legal in your area.

Prior to the installation of this suspension system perform a front end alignment and record. Do not install this system if the vehicle alignment is not within factory specifications. Check for frame and suspension damage prior to installation.

The installation of this suspension system should be performed by two professional mechanics.

This suspension must be installed with Fabtech shock absorbers.

Use the provided thread locking compound on all hardware.

WARNING- Installation of this system will alter the center of gravity of the vehicle and may increase roll over as compared to stock.

Vehicles that receive oversized tires should check ball joints, uniballs, tie rods ends, pitman arm and idler arm every 2500-5000 miles for wear and replace as needed.

Verify differential fluid is at manufactures recommended level prior to kit installation. Installation of the kit will reposition the differential and the fill plug hole may be in a different position. (For example, if the manufacture recommends 3 quarts of fluid, make sure the diff has 3 quarts of fluid). Check your specific manual for correct amount of fluid.

NOTE: This kit will not fit gas engine vehicles.

RECOMMENDED TIRE/WHEEL SIZES -

Use 37x12.50/R17 tire w/ 17x9 wheels w/ 5" BS w/ minor trimming

Use 37x12.50/R18 tire w/ 18x9 wheels w/ 5" BS w/ minor trimming

Use 37x13.50/R20 tire w/ 20x9.5 wheels w/ 5" BS w/ minor trimming

Use 37x13.50/R22 tire w/ 22x11 wheels w/ 5" BS w/ minor trimming

- INSTRUCTIONS -

FRONT SUSPENSION

1. Disconnect the negative terminal on the battery. Jack up the front end of the truck and support the frame rails with jack stands. **NEVER WORK UNDER AN UNSUPPORTED VEHICLE!** Remove the front tires.
2. **DRIVER SIDE ONLY** - Starting on the driver side, remove the driver side fender liner.
3. Remove the factory shock and discard. Retain factory lower hardware.
4. Disconnect factory sway bar links.
5. Remove factory coil spring and rubber isolator. Retain these parts for later use.
6. Remove the factory pitman arm and discard. Keep hardware.
7. Locate the new FT44172 Fabtech pitman arm and install. Do not reconnect the factory drag link at this time. Reinstall the factory lock washer plus thread locker. Torque to 220ft-lbs.
8. Unthread the factory drag link at the adjuster sleeve and remove adjuster sleeve. **SEE FIGURE 1**

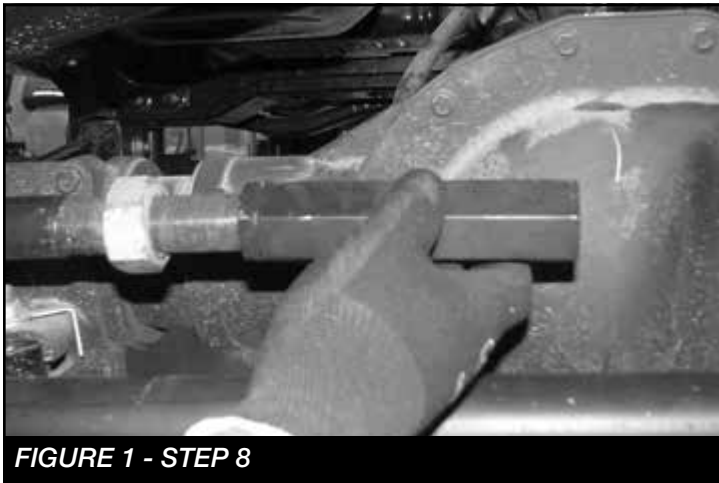

FIGURE 1 - STEP 8

9. Using a die grinder remove the flat nonthreaded section from both ends of the drag link. This will allow you to rotate the drag link and line it up with the pitman arm. **SEE FIGURES 2-4**



FIGURE 2 - STEP 9



FIGURE 3 - STEP 9

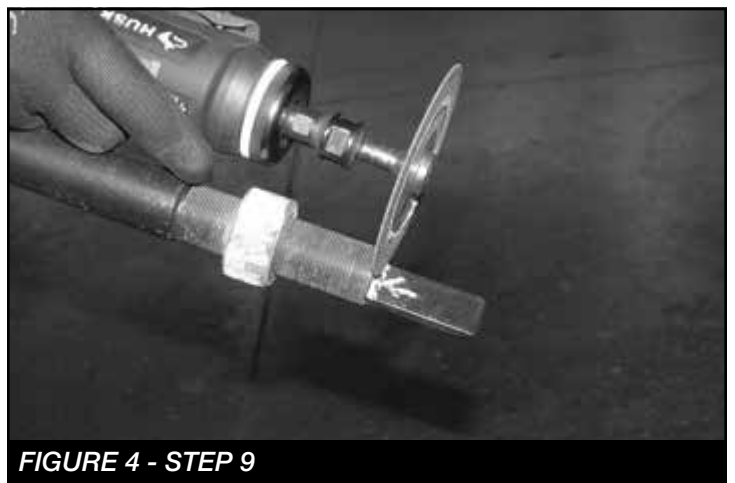

FIGURE 4 - STEP 9

10. Reassemble the drag link and connect it to the new pitman arm. **SEE FIGURE 5**

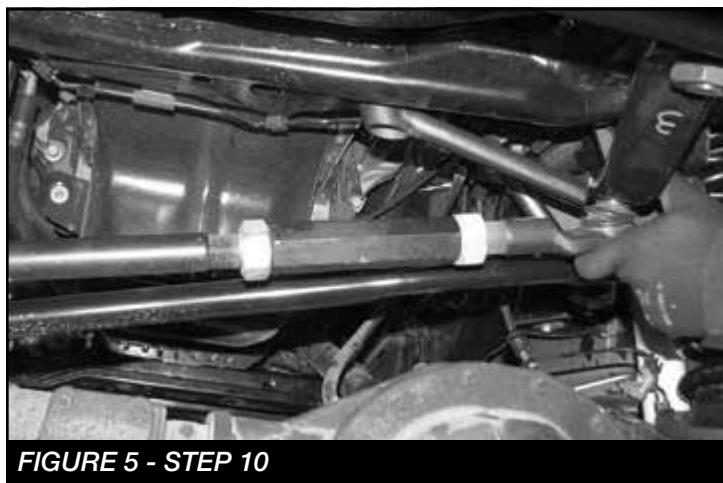

FIGURE 5 - STEP 10

11. Torque the drag link to 83 ft-lbs.
12. Remove the track bar from the frame side of the vehicle.
13. Locate the FT44315BK track bar bracket and M18-2.5 x 90mm bolt.
14. Slide the track bar bracket into the factory mount and insert the M18 bolt into the factory pivot hole. **SEE FIGURE 6**

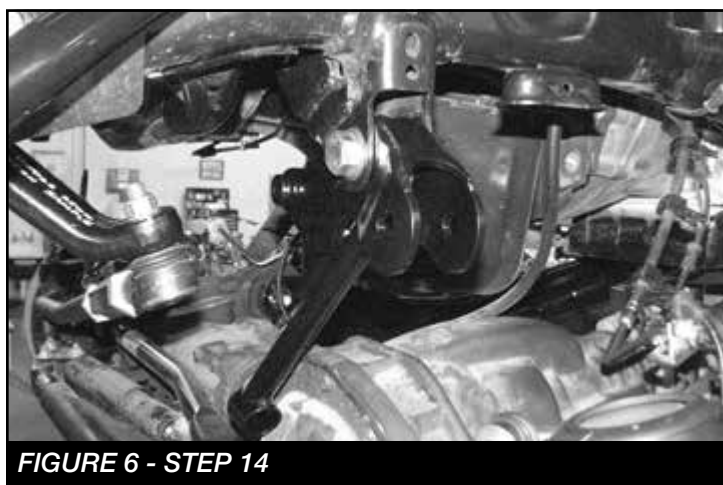

FIGURE 6 - STEP 14

15. Rotate the bracket up until the end of the bracket is flush with the crossmember under the motor.
16. Using the Fabtech bracket as a guide, mark the factory mount for the upper driver side mounting hole.

17. Swing the bracket back out of the way. Using a 1/2" drill bit, drill out the marked hole. **SEE FIGURE 7**



FIGURE 7 - STEP 17

18. Locate one FT44246 sleeve and two 1/2"-13 x 1-1/2" bolts, nuts and washers.
19. Rotate the track bar bracket back into place and bolt together using 1/2"-13 x 1-1/2" bolt and the sleeve. **SEE FIGURES 8-9**

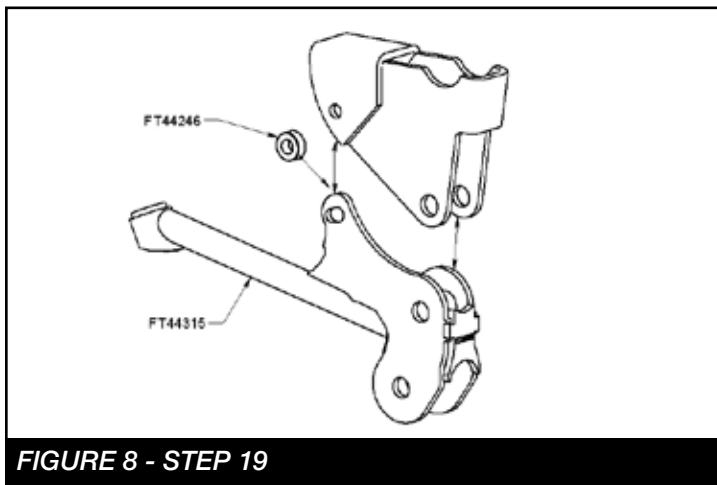

FIGURE 8 - STEP 19



FIGURE 9 - STEP 19

20. Using the Fabtech bracket as a guide, drill a 1/2" hole in the cross member under the motor. Next, mount using 1/2"-13x1.5" and washer. **SEE FIGURE 10**



FIGURE 10 - STEP 20

21. Locate FT44356BK (Coil Retainer), FT44359 (Washer), 1/2"-13 X 4" Bolt, nut and washer. (Driver side) Remove the bolts attaching the ABS module to the spring perch and install the 1/2" bolt and FT44359. Install the FT44356BK (Retainer) and 1/2" washer and nut. Torque to 100 ft-lbs. **SEE FIGURE 11**



FIGURE 11 - STEP 21

22. Locate FT44404BK (lower spring perch spacer), FT44317 (lower spring perch nut tab) and 5/16" hardware. Install the new spring spacer by lining up the existing rear hole. Use the 5/16" hardware and FT44317 nut tab. **SEE FIGURE 12**



FIGURE 12 - STEP 22

23. Using the existing spacer hole as a guide, drill through the factory spring perch using a 11/32" drill bit and install the 5/16" hardware to 29 ft-lbs. **SEE FIGURES 13-14**

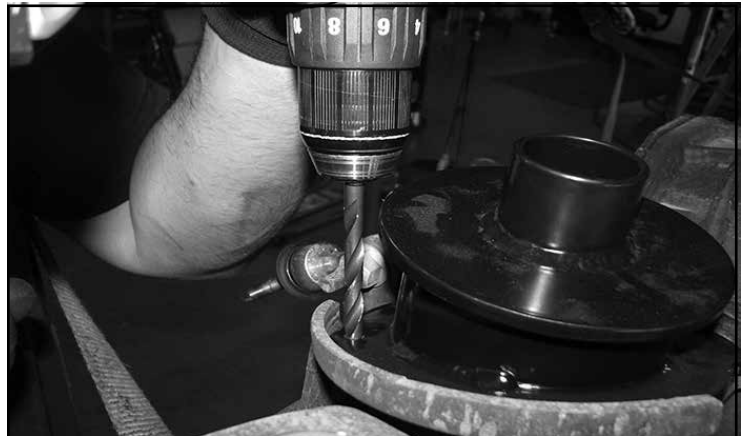

FIGURE 13 - STEP 23



FIGURE 14 - STEP 23

24. Locate and remove the factory rubber bump stop.
SEE FIGURE 15



FIGURE 15 - STEP 24

25. Using a die grinder, grind out the stamped in tabs on the inside of the bump stop housing. **SEE FIGURES 16-17**



FIGURE 16 - STEP 25



FIGURE 17 - STEP 25

26. Locate the FT44402BK driver front bump stop and the FT44135 nut tab.

27. Using a 1/2" drill bit, drill out the hole in the factory crossmember inline with the factory bump stop mount.
SEE FIGURE 18

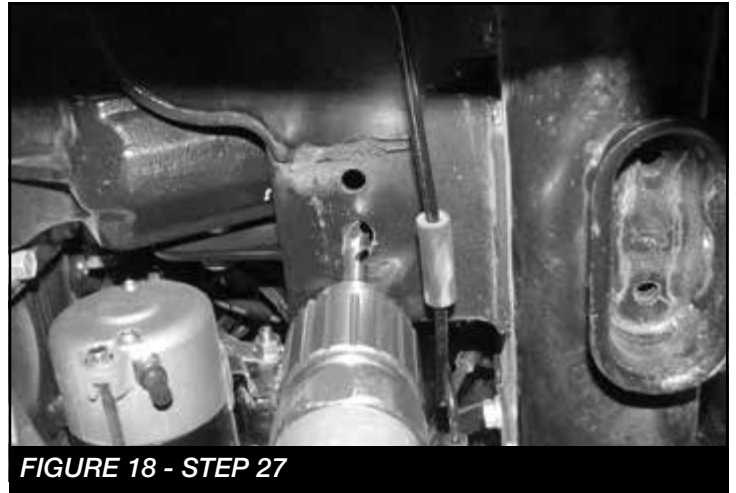

FIGURE 18 - STEP 27

28. Slide the bump stop into the factory bump stop mount. Using a 1/2"-13 x 1-1/4" bolt and the FT44135 (nut tab), bolt the bump stop to the crossmember. Torque the 1/2" bolt to 90 ft-lbs. **SEE FIGURES 19-21**



FIGURE 19 - STEP 28



FIGURE 20 - STEP 28



FIGURE 21 - STEP 28

29. Using the outer tab on the bump stop as a drill guide, drill a 5/16" hole all the way through the factory bump stop mount. **SEE FIGURE 22**



FIGURE 22 - STEP 29

30. Locate a 5/16"-18 x 2-1/2" bolt, nut and washers. Using this bolt, secure the bump stop to the factory bump stop mount and torque to 29 ft-lbs. **SEE FIGURE 23**



FIGURE 23 - STEP 30

31. Locate the FTS88 bump stop pad and thread it into the bottom of the Fabtech bump stop. **SEE FIGURE 24**

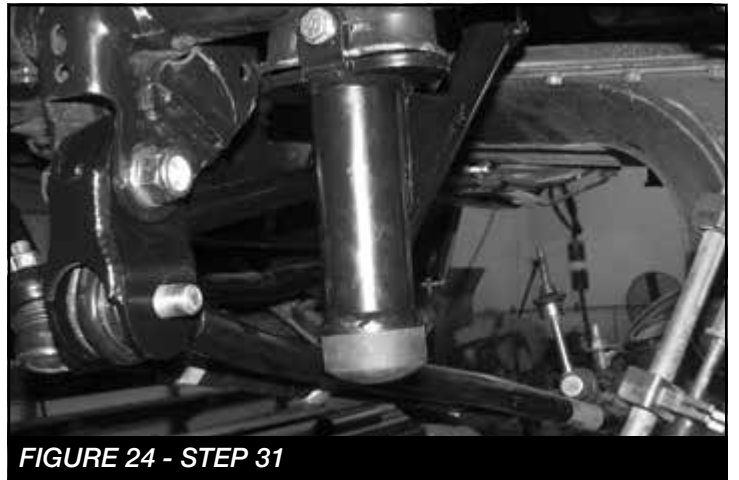

FIGURE 24 - STEP 31

32. Repeat steps 20-31 on the passenger side.
33. Secure the front diff. Remove the factory driver and passenger side Radius arm. Retain Hardware.
SEE FIGURES 25-26



FIGURE 25 - STEP 33



FIGURE 26 - STEP 33

34. Remove the factory crossmember and skid plate that is mounted between the factory radius arm pockets. Retain Hardware. **SEE FIGURE 27**



FIGURE 27 - STEP 34

35. Trim 1/2" off both driver and passenger ends of the crossmember leaving a 1/4" border perpendicular to the bolt holes. This will be done to add clearance for the Fabtech radius arm brackets. **SEE FIGURES 28-29**

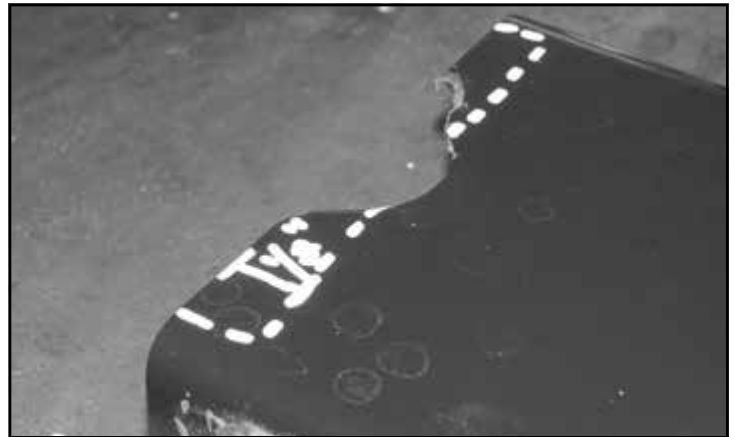

FIGURE 28 - STEP 35



FIGURE 29 - STEP 35

36. Reinstall the factory crossmember and torque to 200 ft-lbs.
37. Locate the Fabtech FT44232BK Radius arm drop bracket and the drill template in the instructions (**Page 19**). Cut out the template.
38. Line up the drill template with the factory Radius arm bracket and mark the two holes around the radius arm pivot bolt. **SEE FIGURE 30**

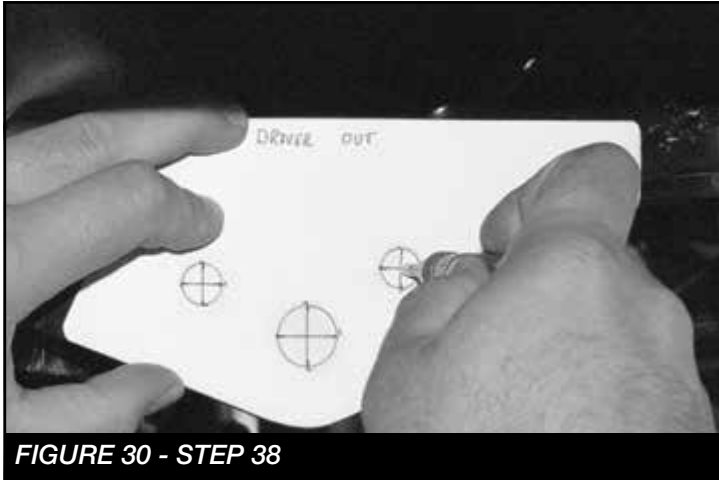

FIGURE 30 - STEP 38

39. Using a 1/2" drill bit, drill all the way through both sides of the factory radius arm mount. **SEE FIGURES 31-32**



FIGURE 31 - STEP 39

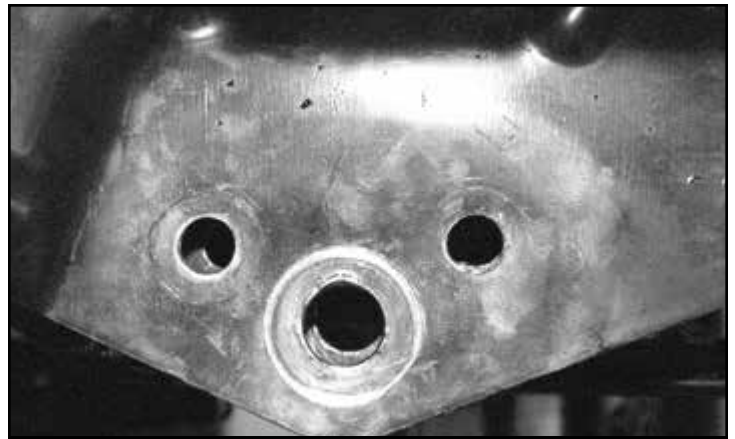

FIGURE 32 - STEP 39

Repeat steps 38-40 on the passenger side.

40. Slide the Fabtech radius arm mount into the factory pocket with the frame tab facing the front of the truck. **SEE FIGURE 33**

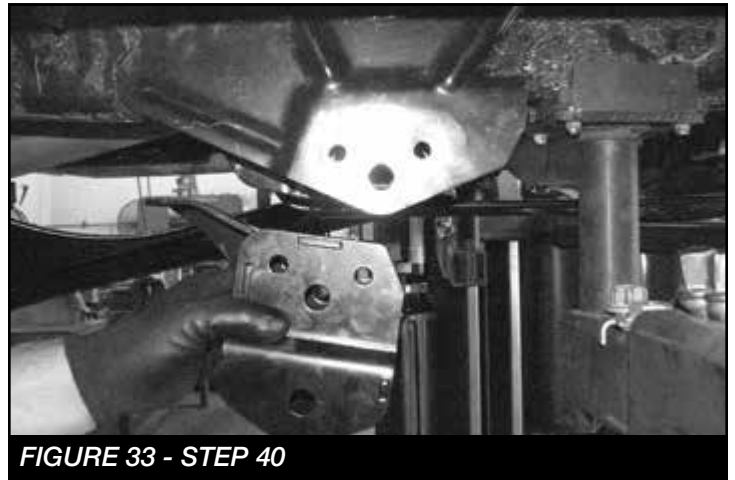

FIGURE 33 - STEP 40

41. Locate four 1/2"-13 x 1-1/4" bolts, nuts and washers. Use these bolts to mount the radius arm drop bracket to the factory bracket. Leave loose at this time. **SEE FIGURE 34**

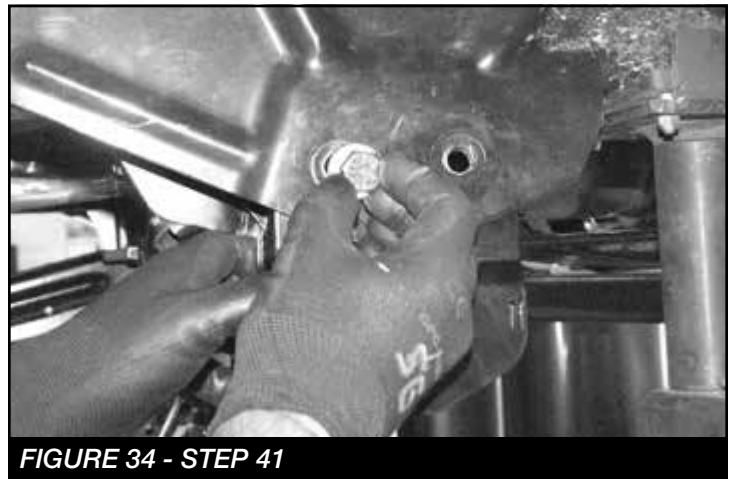

FIGURE 34 - STEP 41

42. Locate the M18-2.5 x 120MM bolt, nut and washers. Pass the 18mm bolt through the factory pivot hole into the FT604 sleeve. Torque the 18mm bolt to 200 ft-lbs and the four 1/2" bolts to 127 ft-lbs. **SEE FIGURES 35-37**



FIGURE 35 - STEP 42

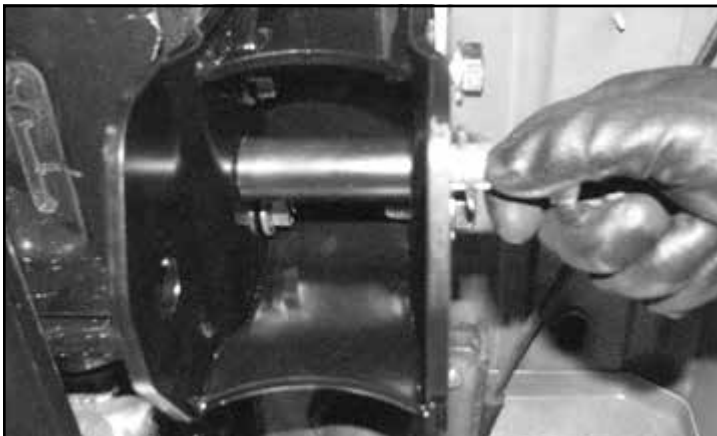

FIGURE 36 - STEP 42

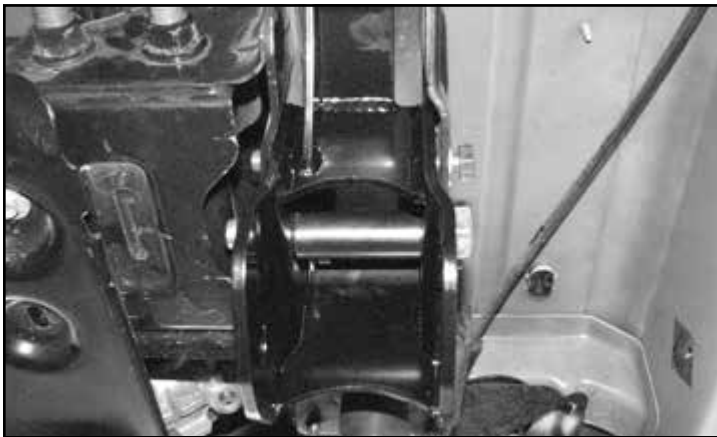

FIGURE 37 - STEP 42

43. Using the Fabtech the radius arm drop bracket as a drill guide, drill a 1/2" hole through the bottom of the frame. **SEE FIGURE 38**



FIGURE 38 - STEP 43

44. Locate a 1/2"-13 x 1-1/4" bolt and the FT44253 nut tab. Pass the nut tab through the hole in the frame forward of the radius arm drop bracket. Connect the bolt and the nut tab through the radius arm drop bracket and the frame. Torque to 127 ft-lbs. **SEE FIGURES 39-41**



FIGURE 39 - STEP 44



FIGURE 40 - STEP 44

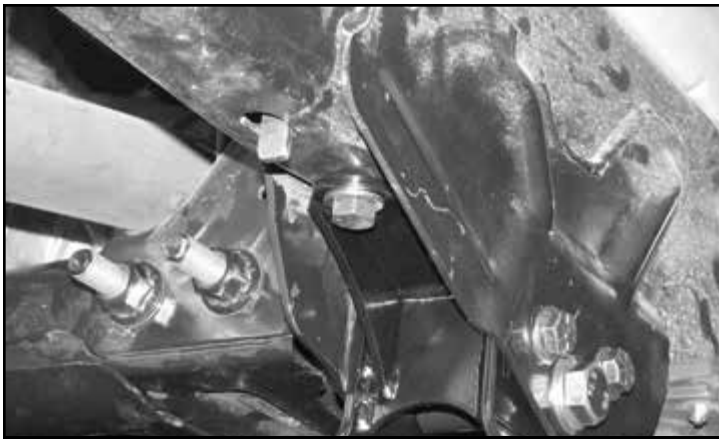

FIGURE 41 - STEP 44

REPEAT STEPS 41-44 ON THE PASSENGER SIDE

- 45. Locate the FT44230BK Driver side radius arm, FT1006 bushing, FT102 sleeve, and zerk fitting.
- 46. Install two bushings, one sleeve, and the zerk fitting into the barrel of the radius arm. **SEE FIGURES 42-44**



FIGURE 42 - STEP 46



FIGURE 43 - STEP 46



FIGURE 44 - STEP 46

- 47. Install the new Fabtech radius arms into the factory frame pocket and onto the axle bushings using the factory hardware. Torque the factory bolts to 200 ft-lbs. **SEE FIGURES 45-47**

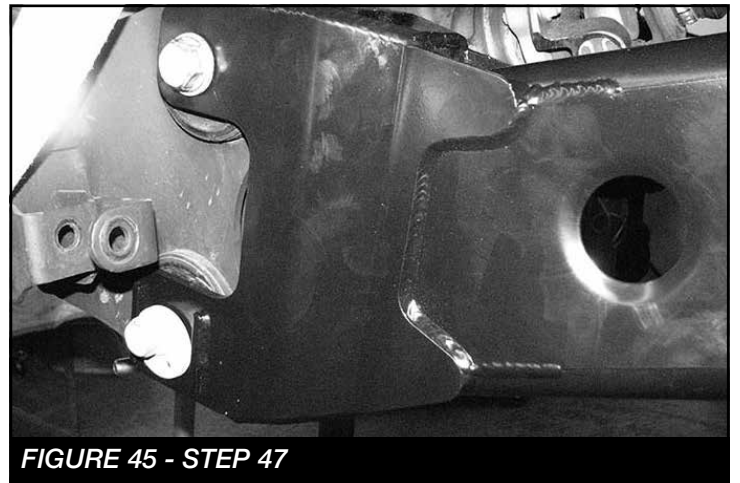

FIGURE 45 - STEP 47

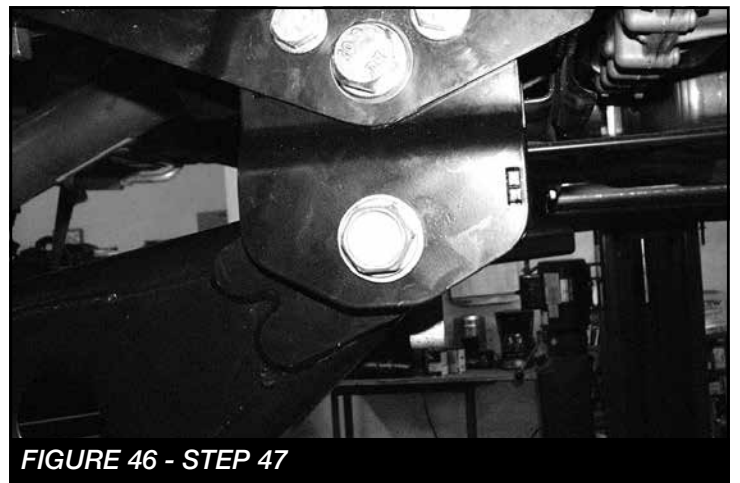

FIGURE 46 - STEP 47



FIGURE 47 - STEP 47

48. Locate the new sway bar drop brackets FT44043 (Driver) and FT44044 (Passenger). Install the new brackets on the frame using the factory hardware. Install the sway bar onto the new brackets using the supplied 7/16" hardware. Torque to 80 ft-lbs. **SEE FIGURE 51**

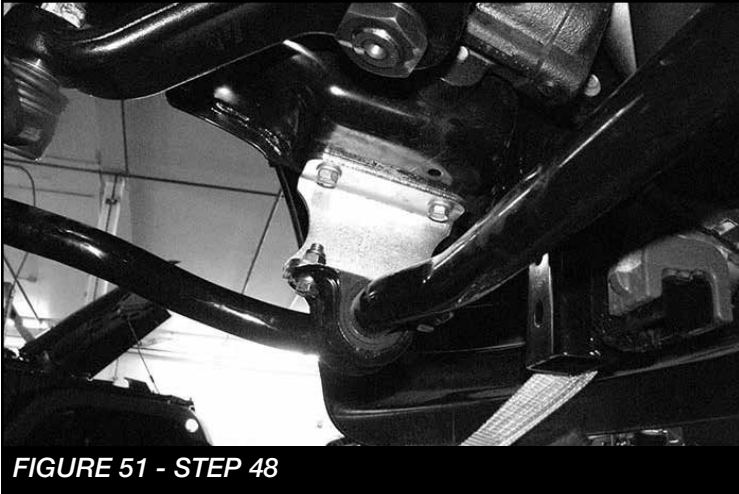

FIGURE 51 - STEP 48

49. Locate and install the new coil spring (FT44320BK) using the factory coil spring isolator. **SEE FIGURE 48**
REPEAT STEP 49 ON PASSENGER SIDE



FIGURE 48 - STEP 49

50. Locate the FT44245 Brake line extension, FT44258 nut tab and two 1/4"-20 x 1" bolts. Attach the brake line extension to the axle using one bolt and the nut tab. Attach the factory brake line bracket to the Fabtech extension. Torque to 10 ft-lbs. Repeat this step on the passenger side. **SEE FIGURES 49-50**



FIGURE 49 - STEP 50

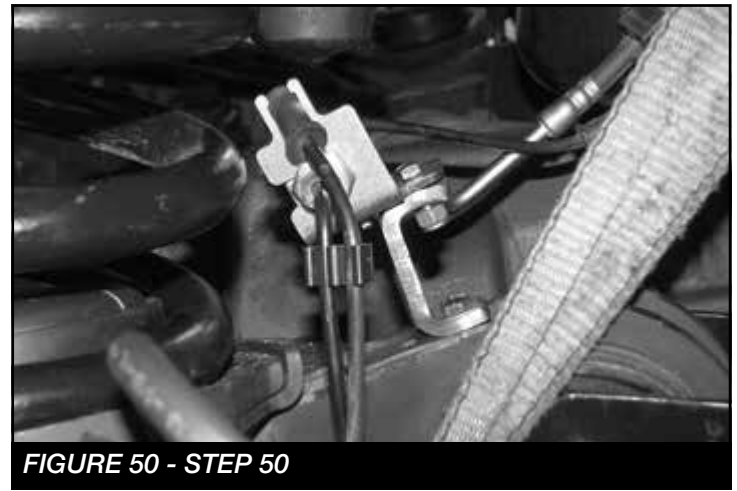

FIGURE 50 - STEP 50

51. Locate the FTS7346 (Performance shock), FTS6346 (Stealth shock) or the FTS801072 (Dirt Logic shock) and install into the factory shock mounts. Torque the upper mount to 14 ft-lbs and the lower 37 ft-lbs. **SEE FIGURES 52-53**

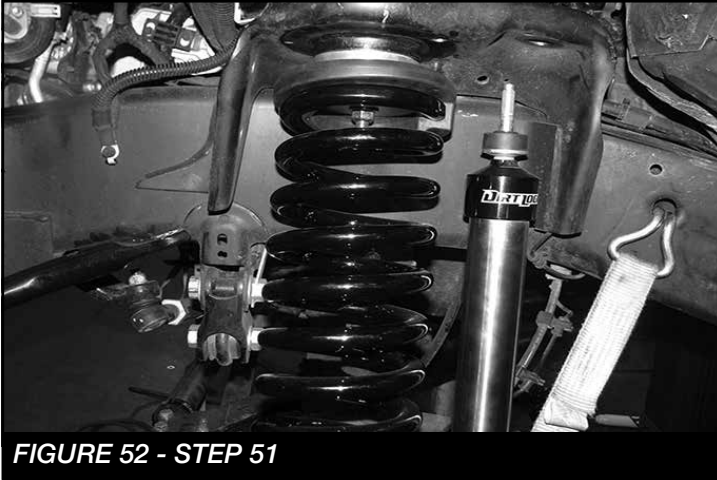

FIGURE 52 - STEP 51

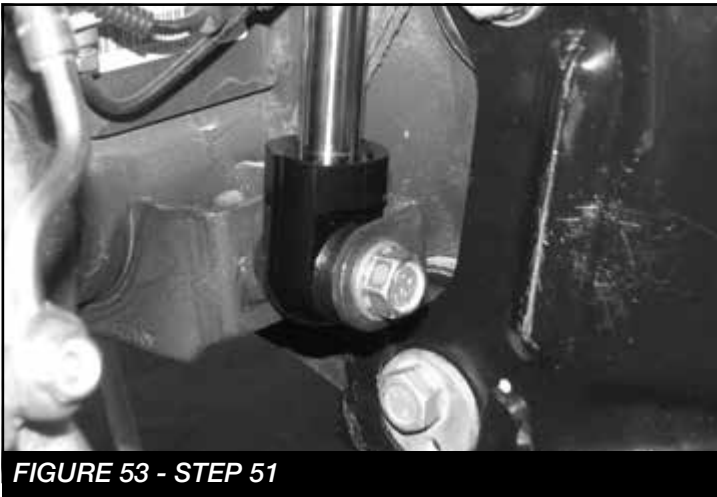

FIGURE 53 - STEP 51

52. Reconnect the factory sway bar. Torque to 29 ft-lbs.

REAR SUSPENSION

53. Jack up the rear end of the vehicle and support the frame rails with jack stands. Supporting the rear differential, remove and discard the rear shocks and u-bolts. Lower the axle down slowly. Use care not to over extend the brake hoses. **SEE FIGURES 54-55**

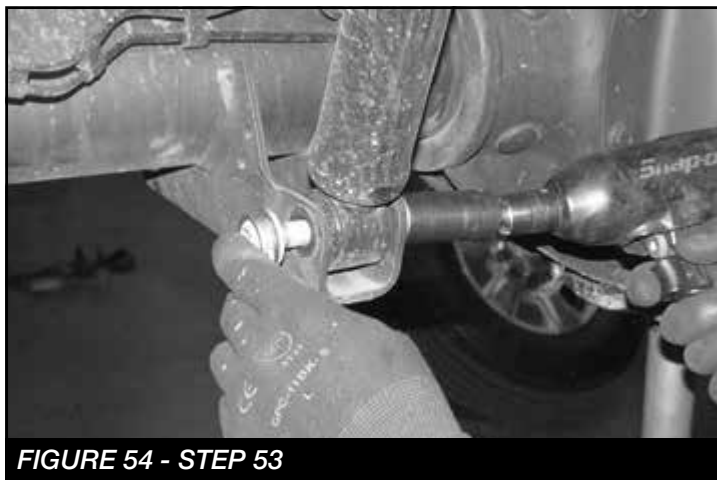

FIGURE 54 - STEP 53



FIGURE 55 - STEP 53

54. Locate FTBK4 (4" Block) and FT160 (Block pin sleeve). Using a drill and 3/4" bit. Drill out the centering pin hole on the block. Next, install the FT160 Sleeve onto the centering pin. **SEE FIGURES 56-57**



FIGURE 56 - STEP 54



FIGURE 57 - STEP 54

55. Install the new blocks onto the axle with the small end of the taper to the front of the truck. Using the supplied u-bolts, nuts and washers, align axle, lift block and springs and torque to u-bolts to 129 ft-lbs.

SEE FIGURES 58



FIGURE 58 - STEP 55

56. Install the FTS7266 (Performance shocks), FTS6063 (Stealth) or FT811192 Dirt Logic 2.25" with the factory hardware and torque upper and lower bolts to 29 ft-lbs.
57. Locate the FT44412BK bump stop extension. Remove driver and passenger factory bump stop. Retain Hardware.
58. Install the bump stop extension to the factory mount using the factory hardware and torque to 65 ft-lbs. Using 7/16"-14 x 1-1/4" bolt, nuts and washers, mount the factory bump stop to the extension. Torque to 59 ft-lbs. **SEE FIGURE 59**

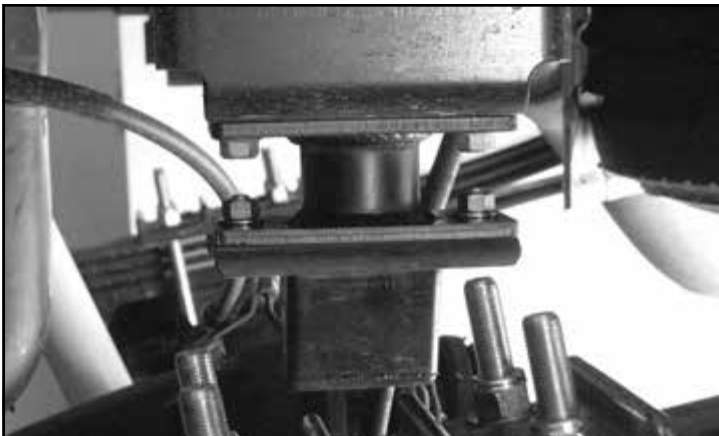

FIGURE 59 - STEP 58

59. Locate FT30496 (Rear Brake Line bracket) Remove the hardware off the factory bracket and install the FT30496 using the factory and supplied 5/16" hardware. Torque to 21 ft-lbs. **SEE FIGURE 60**



FIGURE 60 - STEP 59

60. Install tires and wheels and torque lug nuts to wheel manufacturer's specifications. Turn front tires left to right and check for appropriate tire clearance. **Note - Some oversized tires may require trimming of the front bumper & valance.**
61. Check front end alignment and set to factory specifications. Readjust headlights.
62. Recheck all bolts for proper torque.
63. Recheck brake hoses, ABS wires and suspension parts for proper tire clearance while turning tires fully left to right.
64. Check the fluid in the front and rear differential and fill if needed with factory specification differential oil. **Note - some differentials may expel fluid after filling and driving. This can be normal in resetting the fluid level with the new position of the differential/s.**
65. Install Driver Warning Decal. Complete product registration card and mail to Fabtech in order to receive future safety and technical bulletins on this suspension.

Vehicles that will receive oversized tires should check ball joints, uniballs and all steering components every 2500-5000 miles for wear and replace as required.

RETORQUE ALL NUTS, BOLTS AND LUGS AFTER 50 MILES AND PERIODICALLY THEREAFTER.

FT44232 - TEMPLATE

PRINT AT 100% - DO NOT SCALE TO PAGE

