



INSTALLATION INSTRUCTIONS



2011-15 GM C/K2500HD & C/K3500HD 2WD/4WD

4" UNIBALL UPPER CONTROL ARMS

FTS21126



- PARTS LIST -

	FTS21126	4" HD UNIBALL UCA KIT
1	FT20575BK	UCA DRIV ASMBLD
1	FT20576BK	UCA PASS ASMBLD
1	FT20593	HARDWARE SUBASSEMBLY

	FT20593	HARDWARE SUBASSEMBLY
1	FT90121	HARDWARE KIT
4	FT147	HD MISALIGNMENT
2	FT20579	UNIBALL SPACER
1	FT90111	BUSHING KIT
4	FT84	GREASE FITTING 1/4-28
2	FT20582	UNIBALL ADAPTER PIN
2	FT21126I	INSTRUCTIONS
1	FTLUBE	URETHANE LUBE 1 PACKET
1	FTLOCK	THREAD LOCKING COMPOUND 1 MIL
4	12008007100	ZIP TIE 8" BLACK 40 LBS

	FT90121	HARDWARE KIT
2	56180004152	9/16" -18 C LOCK NUT
2	56000005052	9/16 SAE WASHER G5 ZINC
2	75160004152	3/4-16 C-LOCK NUT ZINC

	FT90111	BUSHING KIT
4	FT77	SLEEVE 1.000 X .630 X 2.620
8	FT1038	BUSHING BLACK URETHANE 88 A

- TOOL LIST -

Required Tools (Not Included)

- Basic Hand Tools
- Floor Jack
- Jack Stands
- Assorted Metric and S.A.E sockets, and Allen wrenches
- Torque Wrench
- Torsion Bar Removal Tool

- PRE-INSTALLATION NOTES -

Read this before you begin installation-

Read all instructions thoroughly from start to finish before beginning the installation. If these instructions are not properly followed severe frame, driveline and / or suspension damage may occur.

Check your local city and state laws prior to the installation of this system for legality. Do not install if not legal in your area.

Prior to the installation of this suspension system perform a front end alignment and record. Do not install this system if the vehicle alignment is not within factory specifications. Check for frame and suspension damage prior to installation.

The installation of this suspension system should be performed by two professional mechanics.

Use the provided thread locking compound on all hardware.

Must be installed on existing Fabtech 4" Ultimate System (K1055 or K1056DB).

This suspension must be installed with Fabtech shock absorbers.

WARNING- Installation of this system will alter the center of gravity of the vehicle and may increase roll over as compared to stock.

- INSTRUCTIONS -

1. Disconnect the negative terminal on the battery. Jack up the front end of the truck and support the frame rails with jack stands. **NEVER WORK UNDER AN UNSUPPORTED VEHICLE!** Remove the front tires.
2. Locate the torsion bar adjusting keys and threaded bolts. Measure exposed threads of torsion bar adjusting bolts and record for reinstallation. Use a torsion bar removal tool to unload the torsion bars. NOTE- Do not attempt to unload or remove torsion bars without the proper torsion bar tool. Torsion Bars are under extreme spring load. Remove the Torsion Bar bolt and nut. Remove the torsion bar tool so the torsion bars are completely unloaded.
3. Remove the upper ball joint nut. Disconnect the upper ball joint from the knuckle by striking the knuckle with a large hammer next to the upper ball joint on the knuckle to dislodge the ball joints. Use care not to hit the ball joints when removing.
4. Mark the location of the alignment cams on the frame of the upper control arm pocket. Remove the upper control arm and retain the factory hardware. **SEE FIGURE 1**

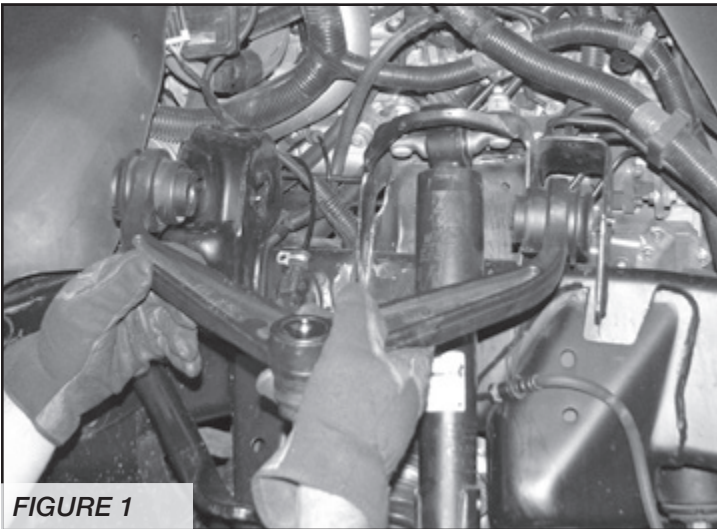

FIGURE 1

5. Locate the Fabtech driver's side control arm FT20575BK, four bushings FT1038; two grease zerks FT84, and two sleeves FT77.
6. Install all these components in the control arm barrels. **SEE FIGURE 2**

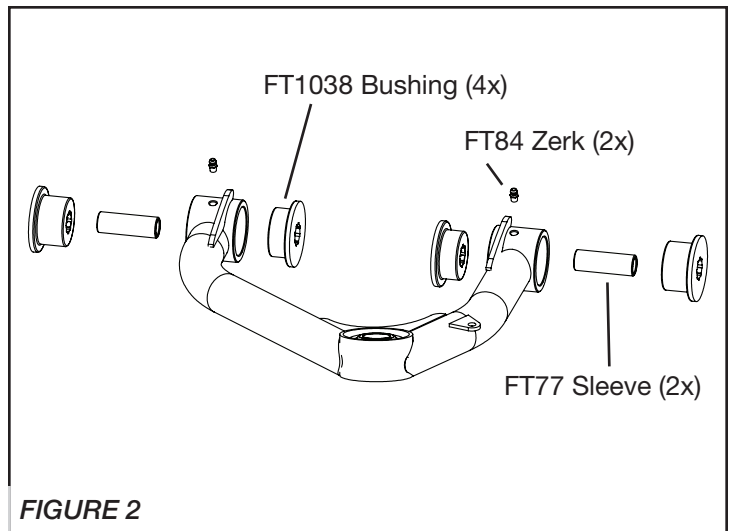
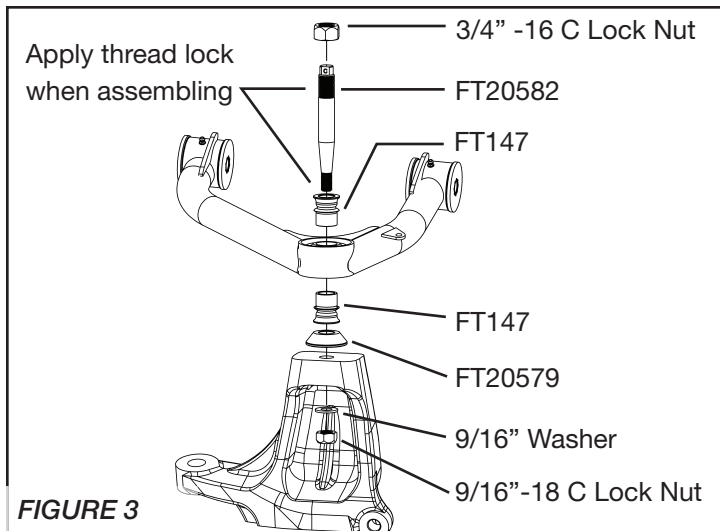

FIGURE 2

7. Install the new Fabtech upper control arm in the factory upper control arm pockets using the factory hardware at the previously marked alignment cam location. When installing the arm on the truck make sure the barrel gussets are up. Torque to 150 ft- lbs.
8. Locate FT20582 Uniball adapter pin, and two 147 uniball misalignment spacers. **SEE FIGURE 3 FOR STEPS 9-14**
9. Insert the uniball pin into the factory knuckle upper ball joint taper. Install the 9/16"-18 lock nut with thread lock compound and flat washer on to the bottom side of the pin. This will lock the pin into the knuckle. Torque to 129 ft-lbs.
10. Install one FT20579 uniball spacer onto the uniball pin mounted in the knuckle with the large side toward the knuckle.
11. Install one FT147 uniball misalignment spacer on to the pin.
12. Swing the control arm down, slide the pin into the uniball on the control arm seating the lower FT147 spacer in the control arm.
13. Install the upper FT147 uniball misalignment spacer onto the pin.
14. Install the 3/4" -16 lock nut on the top side of the pin with thread lock compound and torque to 250 ft-lbs.



15. Repeat 3-14 on the passenger side of the vehicle.
16. Reinstall torsion bar hardware using your previously recorded measurements.
17. Install tires and wheels and torque lug nuts to wheel manufacturer's specifications. Turn front tires left to right and check for appropriate tire clearance. **Note - Some oversized tires may require trimming of the front bumper & valance.**
18. Check front end alignment and set to factory specifications. Readjust headlights.
19. Recheck all bolts for proper torque.
20. Recheck brake hoses, ABS wires and suspension parts for proper tire clearance while turning tires fully left to right.
21. Install Driver Warning Decal. Complete product registration card and mail to Fabtech in order to receive future safety and technical bulletins on this suspension

Vehicles that will receive oversized tires should check ball joints and all steering components every 2500-5000 miles for wear and replace as required.

RETORQUE ALL NUTS, BOLTS AND LUGS AFTER 50 MILES AND PERIODICALLY THEREAFTER.

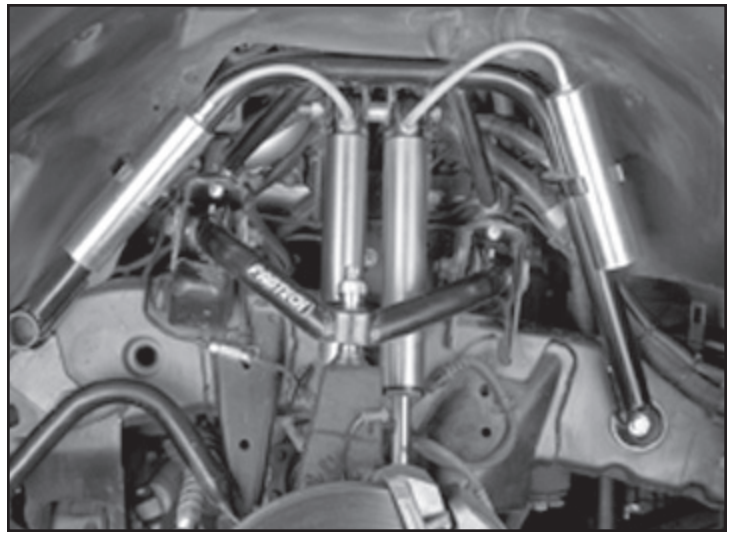

FINISHED INSTALL