



INSTALLATION INSTRUCTIONS



UNIBALL UPPER CONTROL ARMS

FTS26044 - 2010-15 TOYOTA FJ 2WD/4WD

FTS26045 - 2006-09 TOYOTA FJ 2WD/4WD

FTS26046 - 2005-15 TOYOTA TACOMA 2WD/4WD



- PARTS LIST -

	FTS26044	0-6" 2010-15 FJ UNIBALL UCA KIT
1	FT70191BK	UCA DRIVER
1	FT70192BK	UCA PASSENGER
2	FT70166	SWAY BAR RE-LOCATOR
1	FT70184	HARDWARE SUBASSEMBLY

	FTS26045	0-6" 2006-09 FJ UNIBALL UCA KIT
1	FT70191BK	UCA DRIVER
1	FT70192BK	UCA PASSENGER
2	FT70148	SWAY BAR RE-LOCATOR
1	FT70184	HARDWARE SUBASSEMBLY

	FT70184	HARDWARE SUBASSEMBLY
4	FT1002	BUSHING UCA HALF
4	FT174	SLEEVE .750 X .560 X 2.300
2	FT26044I	INSTRUCTIONS
8	FT58-1	WASHER 2.188 X .563 X .188
1	FT70185	HARDWARE KIT
1	FTAS16	DRIVER WARNING DECAL
1	FTREGCARD	REGISTRATION CARD
4	FTS1001	A-ARM BUSHING
2	FT94508	UNIBALL ADAPTER PIN
4	FT147	HD MISALIGNMENT
1	FTLUBE	URETHANE LUBE 1 PACKET

	FT70184	HARDWARE SUBASSEMBLY
4	FT1002	BUSHING UCA HALF
4	FT174	SLEEVE .750 X .560 X 2.300
2	FT26044I	INSTRUCTIONS
4	FT58-1	WASHER 2.188 X .563 X .188
1	FT70185	HARDWARE KIT
1	FTAS16	DRIVER WARNING DECAL
1	FTREGCARD	REGISTRATION CARD
4	FTS1001	A-ARM BUSHING
2	FT94508	UNIBALL ADAPTER PIN
4	FT147	HD MISALIGNMENT
1	FTLUBE	URETHANE LUBE 1 PACKET

	FT70185 - HARDWARE KIT	LOCATION
2	9/16" -18 C LOCK NUT	CONTROL ARM
2	9/16 SAE WASHER G5 ZINC	
2	3/4-16 C-LOCK NUT ZINC	
2	COTTER PIN 1/8 X 2	TIE ROD
4	1/4 SAE WASHER G5 ZINC	BRAKE LINE
2	1/4-20 NYLOCK NUT SS	
2	1/4-20 X 3/4 HEX BOLT G5 ZINC	
4	3/8 SAE WASHER G8 ZINC	SWAY BAR
4	3/8 LOCK WASHER ZINC	
4	3/8-16 X 1 HEX BOLT G8 ZINC	
2	CLAMP	BRAKE LINE
4	GREASE FITTING 1/4-28	CONTROL ARM
2	THREAD LOCKING COMPOUND 1 MIL	
4	ZIP TIE 8" BLACK	

	FT70185 - HARDWARE KIT	LOCATION
2	9/16" -18 C LOCK NUT	CONTROL ARM
2	9/16 SAE WASHER G5 ZINC	
2	3/4-16 C-LOCK NUT ZINC	
2	COTTER PIN 1/8 X 2	TIE ROD
4	1/4 SAE WASHER G5 ZINC	BRAKE LINE
2	1/4-20 NYLOCK NUT SS	
2	1/4-20 X 3/4 HEX BOLT G5 ZINC	
4	3/8 SAE WASHER G8 ZINC	SWAY BAR
4	3/8 LOCK WASHER ZINC	
4	3/8-16 X 1 HEX BOLT G8 ZINC	
2	CLAMP	BRAKE LINE
4	GREASE FITTING 1/4-28	CONTROL ARM
2	THREAD LOCKING COMPOUND 1 MIL	
4	ZIP TIE 8" BLACK	



- PARTS LIST CONTINUED -

- TOOL LIST -

	FTS26046	0-6" 2005-15 TACOMA UNIBALL UCA KIT
1	FT70191BK	UCA DRIVER
1	FT70192BK	UCA PASSENGER
2	FT70148	SWAY BAR RE-LOCATOR
1	FT70193	HARDWARE SUBASSEMBLY

	FT70193	HARDWARE SUBASSEMBLY
4	FT1002	BUSHING UCA HALF
4	FT174	SLEEVE .750 X .560 X 2.300
2	FT26044I	INSTRUCTIONS
4	FT58-1	WASHER 2.188 X .563 X .188
1	FT70185	HARDWARE KIT
1	FTAS16	DRIVER WARNING DECAL
1	FTREGCARD	REGISTRATION CARD
4	FTS1001	A-ARM BUSHING
2	FT94509	UNIBALL ADAPTER PIN
4	FT147	HD MISALIGNMENT
1	FTLUBE	URETHANE LUBE 1 PACKET

Required Tools (Not Included)

Basic Hand Tools
 Floor Jack & Jack Stands
 Assorted Metric and S.A.E sockets, and Allen wrenches
 Torque Wrench
 Barrel Sander
 Drill & Drill Bits

	FT70185 - HARDWARE KIT	LOCATION
2	9/16" -18 C LOCK NUT	CONTROL ARM
2	9/16 SAE WASHER G5 ZINC	
2	3/4-16 C-LOCK NUT ZINC	
2	COTTER PIN 1/8 X 2	TIE ROD
4	1/4 SAE WASHER G5 ZINC	BRAKE LINE
2	1/4-20 NYLOCK NUT SS	
2	1/4-20 X 3/4 HEX BOLT G5 ZINC	
4	3/8 SAE WASHER G8 ZINC	SWAY BAR
4	3/8 LOCK WASHER ZINC	
4	3/8-16 X 1 HEX BOLT G8 ZINC	
2	CLAMP	BRAKE LINE
4	GREASE FITTING 1/4-28	CONTROL ARM
2	THREAD LOCKING COMPOUND 1 MIL	
4	ZIP TIE 8" BLACK	



- PRE-INSTALLATION NOTES -

Read This Before You Begin Installation:

- Read all instructions thoroughly from start to finish before beginning the installation. If these instructions are not properly followed severe frame, driveline and / or suspension damage may occur.
- Check your local city and state laws prior to the installation of this system for legality. Do not install if not legal in your area.
- Prior to the installation of this suspension system perform a front end alignment and record. Do not install this system if the vehicle alignment is not within factory specifications. Check for frame and suspension damage prior to installation.
- The installation of this suspension system should be performed by two professional mechanics.
- Use the provided thread locking compound on all hardware.
- WARNING - Installation of this system will alter the center of gravity of the vehicle and may increase roll over as compared to stock.
- Vehicles that receive oversized tires should check ball joints, uniballs, tie rods ends, pitman arm and idler arm every 2500 5000 miles for wear and replace as needed.

Footnotes:

- Must use 17" wheels or larger.
- If installing the optional Dirt Logic coilover, record the ride height of the vehicle so that the proper ride height can be done when completed.
- System does not fit models with factory electronic controlled shocks.

Recommend Tires and Wheels:

Use 33/12.50R17 tire w/ 17x8 wheels w/ 4-5/8" BS w/ minor trimming

- INSTRUCTIONS -

1. Disconnect the negative terminal on the battery. Jack up the front end of the truck and support the frame rails with jack stands. **NEVER WORK UNDER AN UNSUPPORTED VEHICLE!** Remove the front tires.
2. Starting on the drivers side remove the upper ball joint nut. Disconnect the upper ball joint from the knuckle by striking the knuckle with a large hammer next to the upper ball joint on the knuckle to dislodge the ball joints. Use care not to hit the ball joints when removing.
3. Remove the upper control arm and retain the factory hardware. **SEE FIGURE 1**

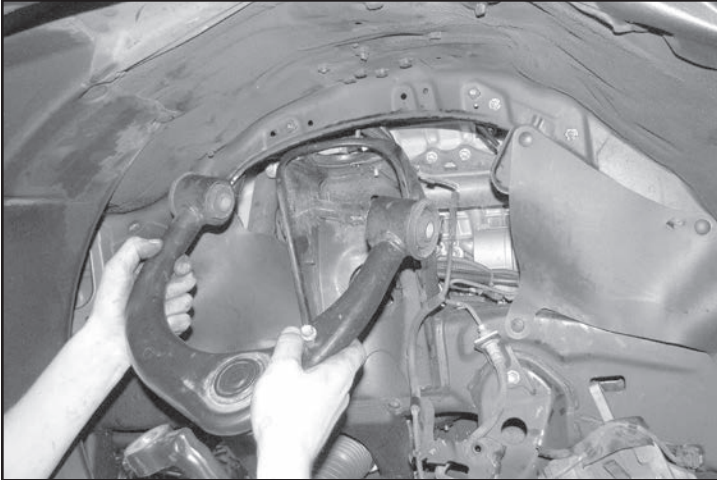

FIGURE 1

IF INSTALLING DIRT LOGIC 2.5 COILOVERS PROCEED WITH STEP 4. OTHERWISE SKIP TO STEP 9.

4. Support the lower A-Arm with a floor jack. Remove the three upper nuts from the top of the shock assembly then the lower bolt from the shock at the lower control arm. Save the hardware. **SEE FIGURES 2-3**

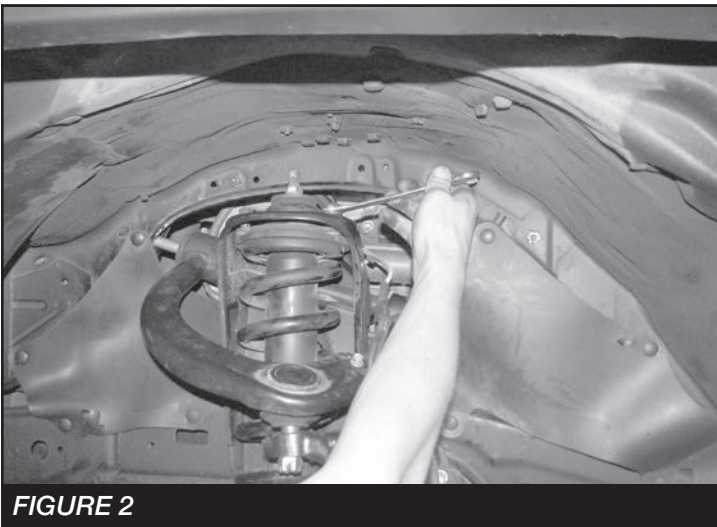

FIGURE 2

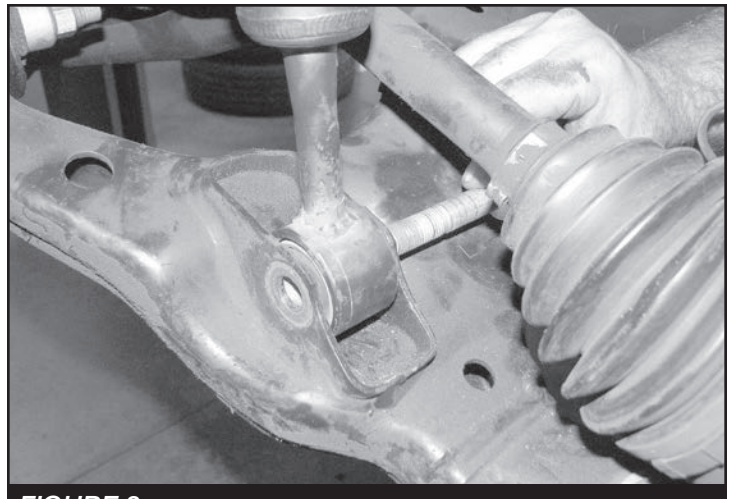

FIGURE 3

5. Using 1-1/2" Barrel sander, sand a small notch in the lip at the top of the bucket. The radius should be on both sides of the bucket parallel to the front of the bucket. This radius is to add clearance the shock pivot bolt.

SEE FIGURES 4-5

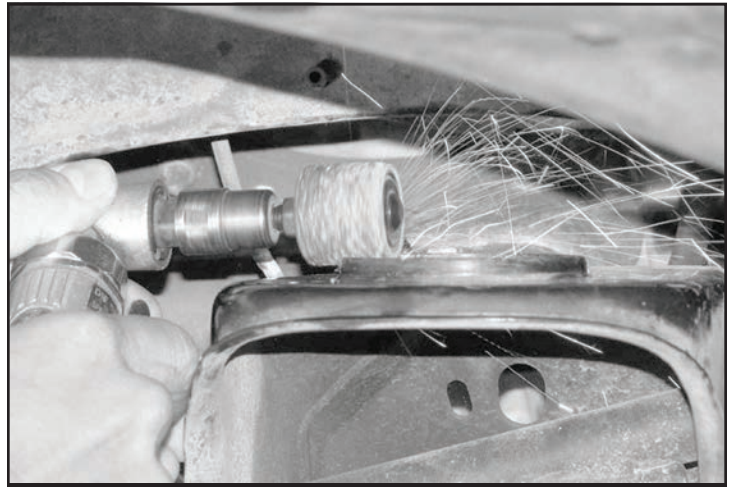

FIGURE 4

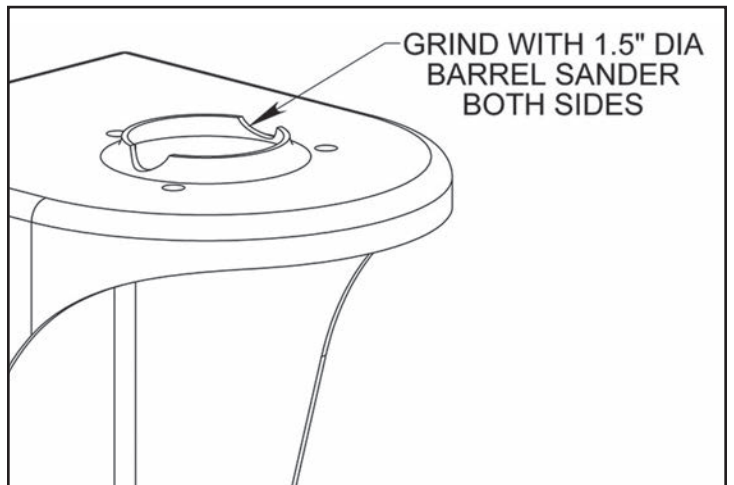

FIGURE 5

6. Locate FT825251 or FT820252 Dirt Logic 2.5 Coilover, FT833121 upper mount and supplied 3/8" hardware. Install Coilover FT833121 upper mount inside the factory coilover bucket using the supplied 3/8" hardware and torque 37 FT-LBS. **SEE FIGURES 6-7**

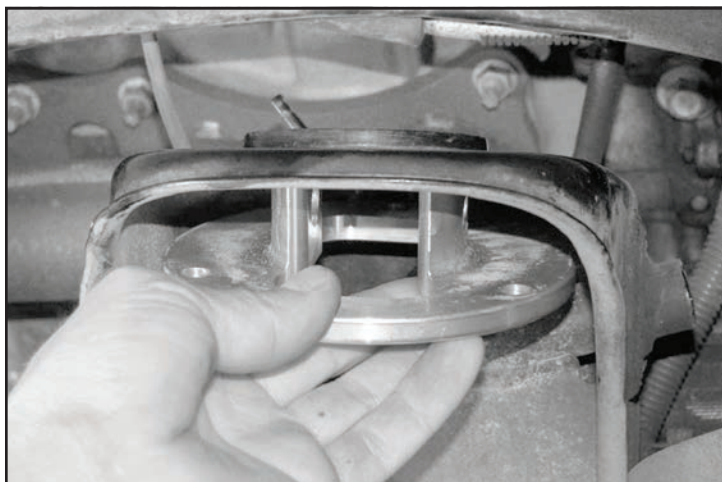

FIGURE 6

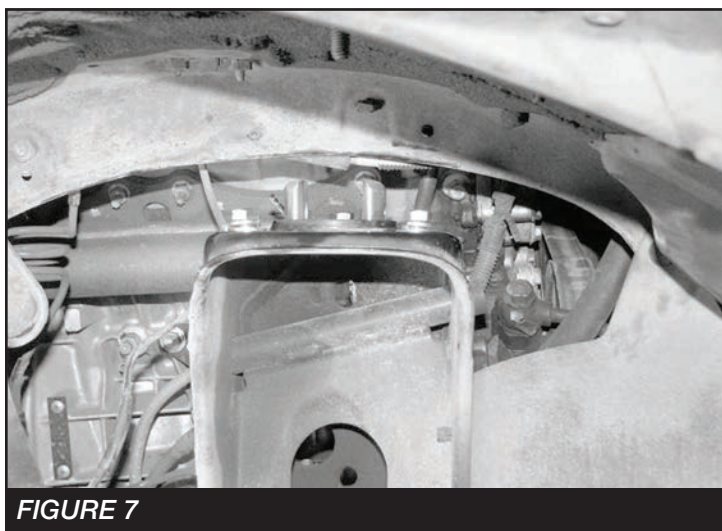

FIGURE 7

7. Install the FT825251 or FT820252 Coilover into the new upper mount using the 1/2"-13 x 2-1/4 bolt from the shock hardware. Torque 90 FT-LBS. **SEE FIGURES 8-10**

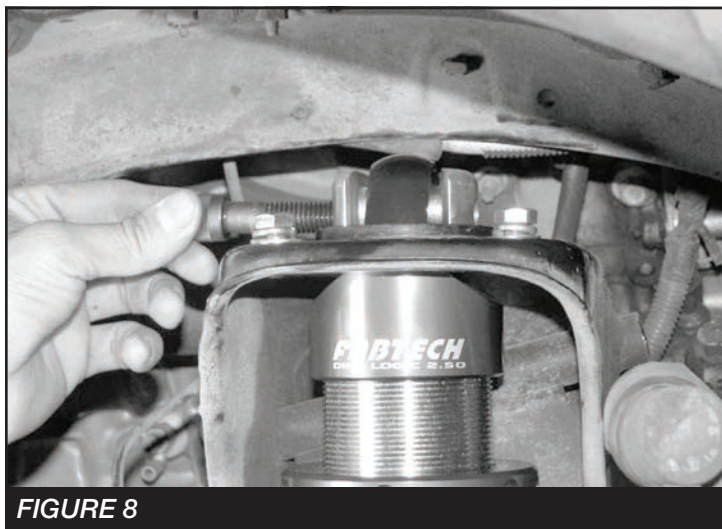

FIGURE 8

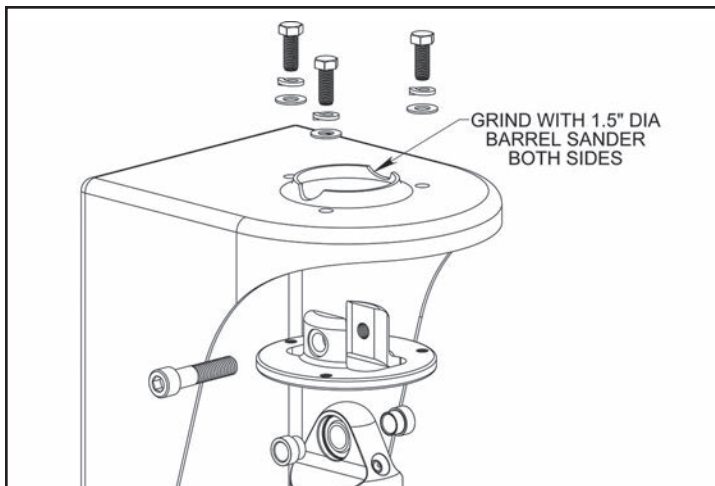

FIGURE 9

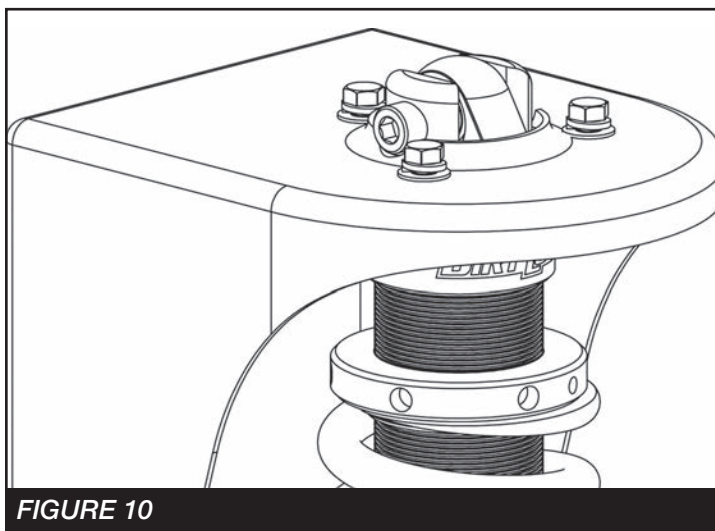

FIGURE 10

8. Install the rod end at the bottom of the shock into the lower control arm with the larger misalignment to the front of the Vehicle. Reinstall the factory bolt into the lower mount. Torque 100 FT-LBS. **SEE FIGURE 11**

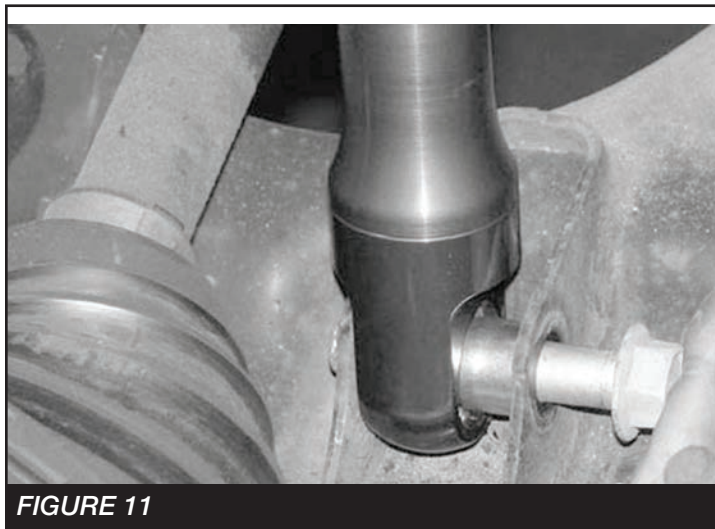

FIGURE 11

9. Locate the Fabtech driver's side control arm FT70191BK, four bushings FTS1001 & FT1002, four FT58-1 washers, two grease zerks FT84 and two sleeves FT174 .

10. Install all these components in the control arm barrels.
SEE FIGURE 12

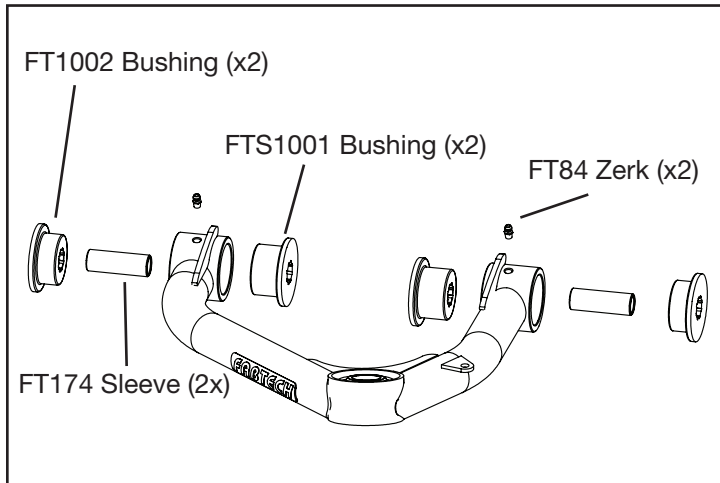

FIGURE 12

11. Install the upper arm using the factory hardware. Place the new FT58-1 washers on the inside and outside of the bushings. When installing the arm on the truck make sure the barrel gussets are up. Torque to 120 FT-LBS. **SEE FIGURES 13-14**

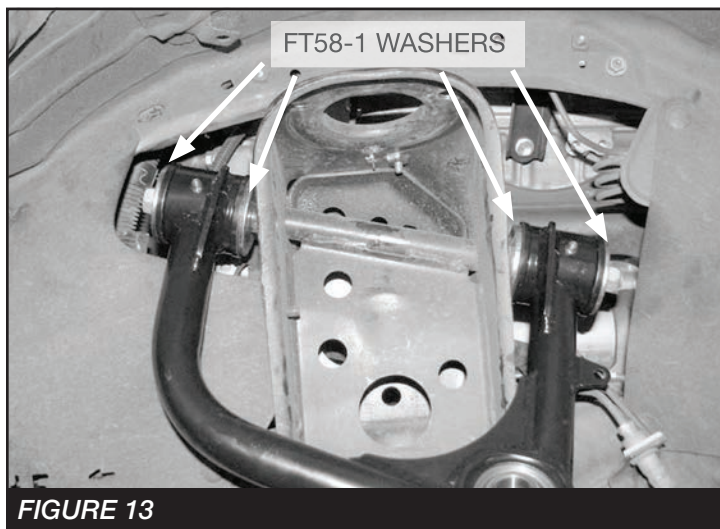

FIGURE 13

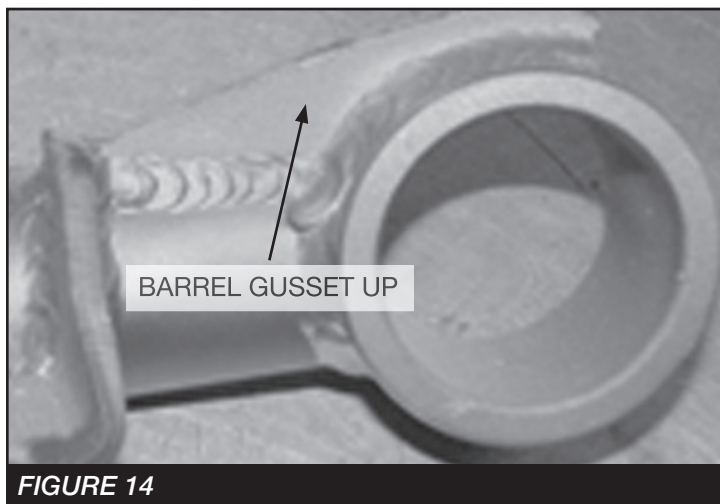

FIGURE 14

12. Locate FT94508 (FJ) or FT94509 (Tacoma) Uniball adapter pin, and two FT147 uniball misalignment spacers.

SEE FIGURE 15 FOR STEPS 13-17

13. Insert the uniball pin into the factory knuckle upper ball joint taper. Install the 9/16"-18 lock nut with thread lock compound and flat washer onto the bottom side of the pin. This will lock the pin into the knuckle. Torque to 150 FT-LBS.
14. Install one FT147 uniball misalignment spacer on to the pin.
15. Swing the control arm down, slide the pin into the uniball on the control arm seating the lower FT147 spacer in the control arm.
16. Install the upper FT147 uniball misalignment spacer onto the pin.
17. Install the 3/4" -16 lock nut on the top side of the pin with thread lock compound and torque to 150 FT-LBS..

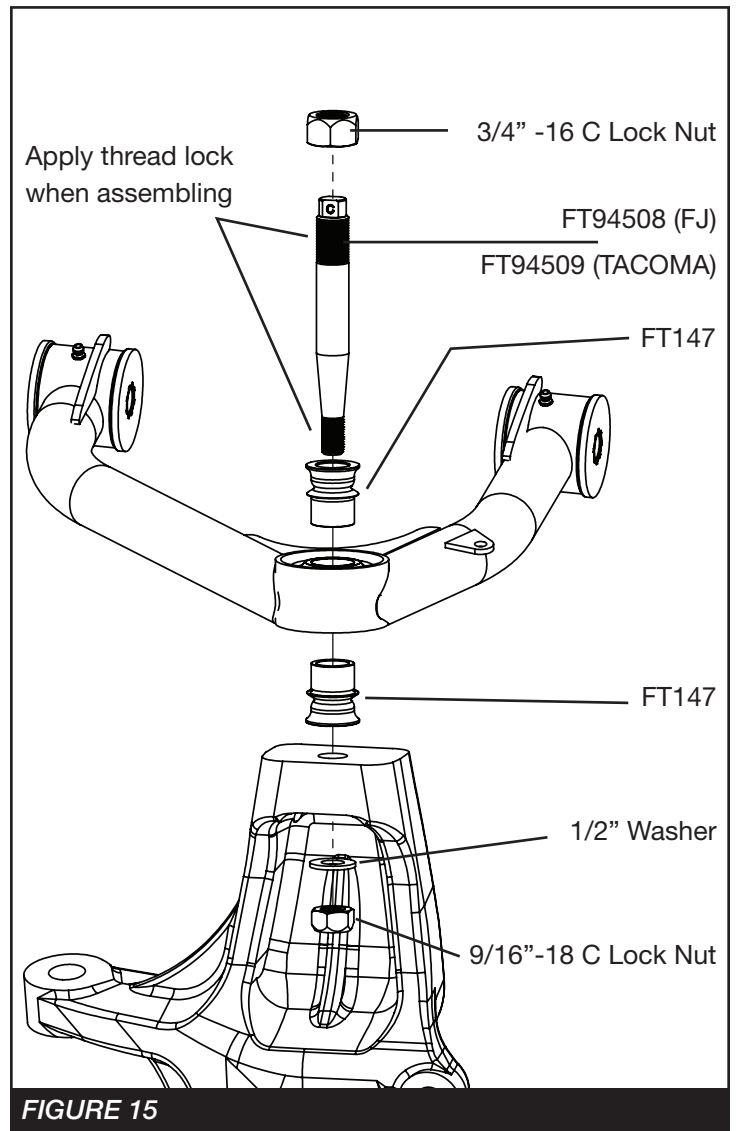

FIGURE 15

18. Using supplied 1/4" hardware, attach Adel clamp to brake line and tab on upper control arm. Torque 10 FT-LBS.
19. Repeat 2-18 on the passenger side of the vehicle.

IF INSTALLING 3" SYSTEM PROCEED WITH STEP 20. OTHERWISE SKIP TO STEP 21.

20. Remove the sway bar at the frame mounts. Locate FT70148 (FJ) or FT70166 (Tacoma) sway bar re-locators, and install into factory sway bar location, using the factory hardware. **NOT FOR USE ON 6" SYSTEMS.** The chamfered edge goes up & toward the rear of the vehicle. Re-install sway bar onto the new mounting plate using the supplied 3/8" hex bolt, lock washer, and washer. Tighten to 52 FT-LBS. **SEE FIGURES 16-18**

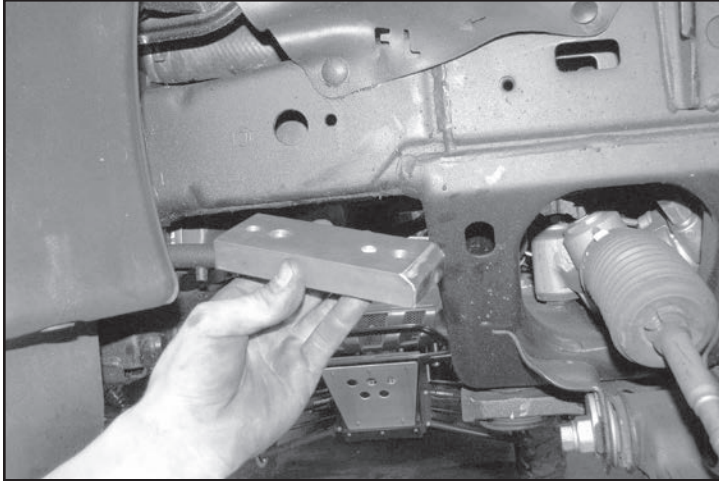

FIGURE 16

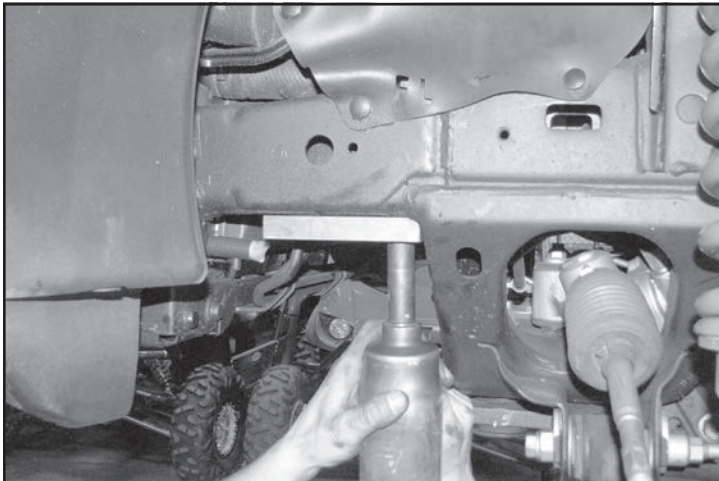

FIGURE 17

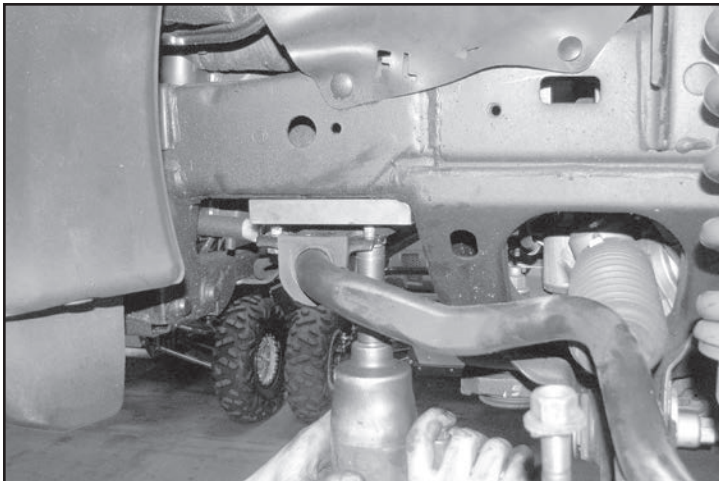

FIGURE 18

21. Install tires and wheels and torque lug nuts to wheel manufacturer's specifications. Turn front tires left to right and check for appropriate tire clearance. **Note - Some oversized tires may require trimming of the front bumper & valance.**
22. Check front end alignment and set to factory specifications. Readjust headlights.
23. Recheck all bolts for proper torque.
24. Recheck brake hoses, ABS wires and suspension parts for proper tire clearance while turning tires fully left to right.
25. Install Driver Warning Decal. Complete product registration card and mail to Fabtech in order to receive future safety and technical bulletins on this suspension.

Vehicles that will receive oversized tires should check ball joints, uniballs and all steering components every 2500-5000 miles for wear and replace as required.

RETORQUE ALL NUTS, BOLTS AND LUGS AFTER 50 MILES AND PERIODICALLY THEREAFTER.