

DESCRIPTION : ELECTROMAGNETIC HORN – LOW TONE FREEWAY BLASTER

AM80S

Main specifications and performances

Nominal voltage	12	Vdc
Voltage range	11.5-13.8	Vdc
Current consumption	9 / each	A
Sound pressure level	115 (2m)	dB(A)
Frequency 'L'		
Frequency 'H'	500	Hz
Operating temperature	-30°C to +80	°C
Storage temperature	-30°C to +80	°C
Corrosion resistance	> 480 (salt spray test)	Hours
Operating relative humidity	30 to 80	%
Durability (1 sec ON, 4 sec OFF)	>50 000	Cycles
Continuous blowing	> 3	min
Electrical insulation	1000	Vdc
Vibration (30 min, 3 axis)	1	g
Weight (each)	220	g
Main Materials	ABS, Steel	
Main applications	Cars, Trucks, Motorcycles	

Dimensions (mm)

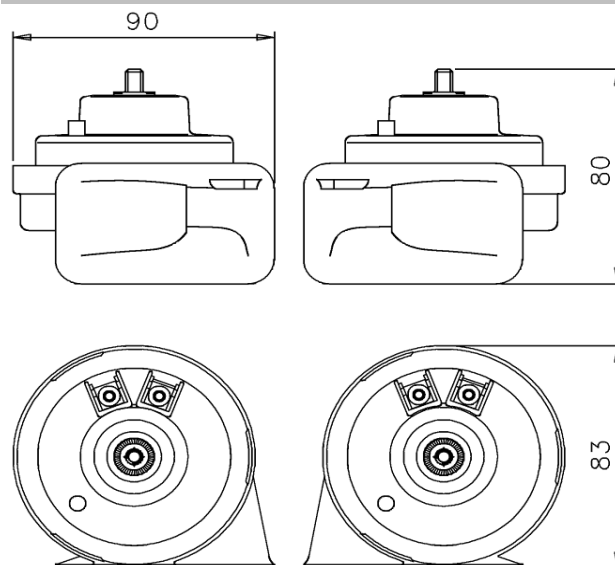

Available Electrical Connection

Double Pole Terminal 6,3x0,8 mm

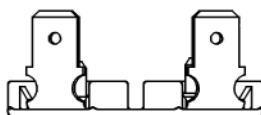

Other specifications

Mechanical connection: flat and rigid surface facing the bracket edge

Horn's Protection: choose an installation area protected from direct water and mud splash

Packaging: Blister

Master carton: 12 pieces

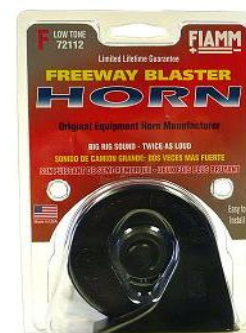

Conformity to Standards of

PRODUCT

C E E 70/388
R. 28 ECE/ONU
CEE 95/54

MANUFACTURING

ISO/TS 16949
SO 9001
SO 14001
QS 9000

Part Numbers

7210223 Freeway Blaster Low