

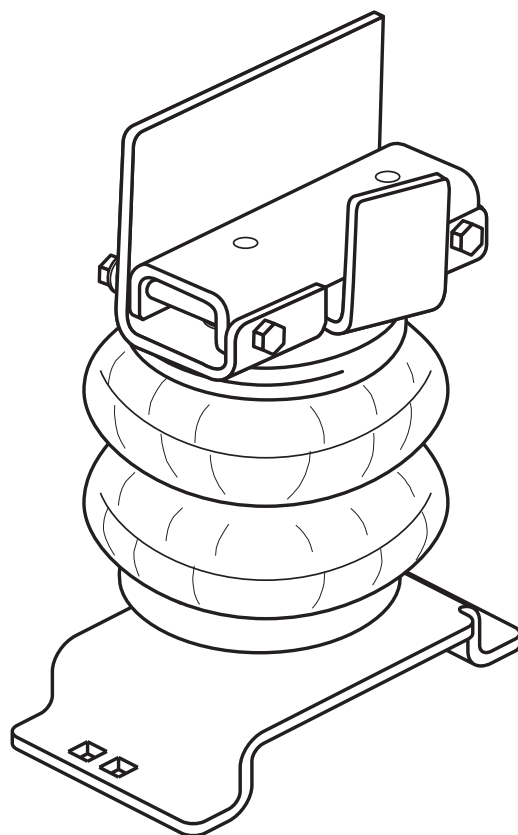

INSTALLATION INSTRUCTIONS



Firestone

*World's Number 1
Air Spring.*



FIRESTONE INDUSTRIAL PRODUCTS COMPANY

! IMPORTANT

PLEASE DON'T HURT YOURSELF, YOUR KIT OR YOUR VEHICLE. TAKE A MINUTE TO READ THIS IMPORTANT INFORMATION.

This kit is to be used on a **pickup truck only**, and **DOES NOT INCREASE YOUR VEHICLE'S MAXIMUM LOAD**.

SAFE INSTALLATION

Please take all safety precautions during installation. A hydraulic jack can fail, and if that happens, you can be seriously hurt, or worse, if you are relying on it to hold up the vehicle. If you use a hydraulic jack, secure jack stands in the appropriate locations and chock any tires still touching the ground.

Wear safety glasses or goggles. Your eyes may be lower than some parts and pieces, and you don't want to lose an eye.

Remove the possibility of any electrical issues by disconnecting the negative battery cable.

KIT CLEARANCE

There must be a minimum of 1/2" clearance around all installed components when the Air Springs are inflated and under a load. The Air Springs must flex and expand during operation, so the clearance keeps the kit from rubbing against parts of the vehicle.

VEHICLE GVWR

NEVER exceed the maximum load recommended by the vehicle manufacturer (GVWR). The GVWR can be found in your vehicle's owner's manual or on the data plate on the driver's side door. Consult your local dealership for additional GVWR specifications.

INFLATING THE AIR SPRINGS

When inflating Air Springs, add air pressure in small quantities, checking air pressure frequently. The Air Springs have much less air volume than a tire, so they inflate much more quickly.

PRESSURE TO LOAD

The Air Springs will support approximately 50 lbs. of load for each PSI of inflation pressure (per pair). For example, 50 PSI of inflation pressure will support a load of 2500 lbs. per pair of Air Springs.

APPROPRIATE AIR PRESSURE

For best ride, use only enough air pressure in the Air Springs to level the vehicle when viewed from the side (front to rear). This will vary, depending on the load, location of the load, condition of the existing suspension, and personal preference.

OPTIONAL T-FITTING

This kit includes Inflation Valves and Air Line Tube for each Air Spring, allowing you to compensate for unbalanced loads. If you prefer a single Inflation Valve system to provide equal pressure to both Air Springs, your dealer can supply the optional "T" fitting (Part # 3025 or WRI-760-3461 retail pack).



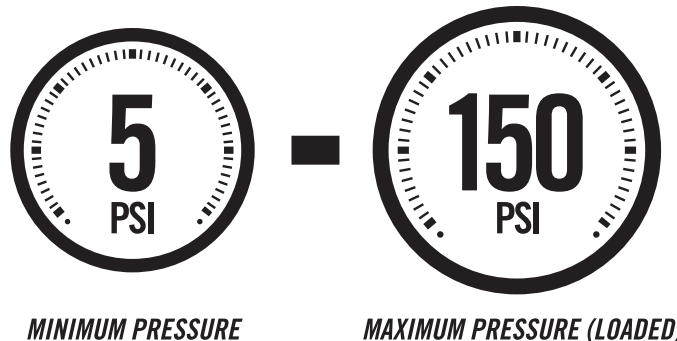

ONCE INSTALLED SUCCESSFULLY, FOLLOW THESE PRESSURE REQUIREMENTS FOR THE AIR SPRINGS:



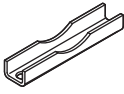
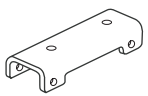
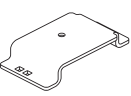

PARTS

Compare the parts below to your kit. Assure you have all pieces, and organize them for an easier installation.

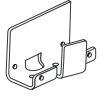









MAIN KIT CONTENTS

PART # 8873	 x 2 AIR SPRING	PART # 5833	 x 1 RIGHT UPPER BRACKET	PART # 5860	 x 2 BRACKET STRAP
PART # 5836	 x 2 FRAME BRACKET	PART # 5847	 x 2 LOWER BRACKET	PART # 9153	 x 1 AIR LINE TUBE (30 FEET)
PART # 5826	 x 1 LEFT UPPER BRACKET				

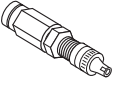
A24-760-7560 INFLATION VALVE BRACKET KIT

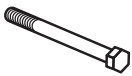
PART # 9483	 x 1 NO-DRILL INFLATION VALVE BRACKET	PART # 9488	 x 2 LARGE NYLON TIE
-------------	--	-------------	--

A21-760-2706 HARDWARE PACK

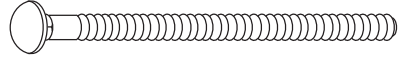
PT # 3488	 x 12 3/8" - 16 NYLOCK NUT	PT # 3293	 x 4 M10 x 1.5 x 30MM FLAT HEAD BOLT	PT # 9168	 x 6 BLACK NYLON TIE
PT # 3458	 x 2 3/8" - 16 x 3/4" FLAT HEAD BOLT	PT # 3032	 x 2 INFLATION VALVE AND VALVE CAP ASSEMBLY	PT # 0899	 x 2 THERMAL SLEEVE
PT # 3268	 x 4 3/8" - 16 x 3 1/2" HEX HEAD BOLT	PT # 3031	 x 2 ELBOW AIR FITTING	PT # 3033	 x 4 5/16" FLAT WASHER
PT # 3493	 x 12 3/8" FLAT WASHER (Use as necessary with 3/8" Nylock Nuts)			PT # 3020	 x 4 3/8" - 16 x 8" CARRIAGE BOLT

CONTENTS AND OVERVIEW

PAGE	4	REMOVE JOUNCE BUMPER
PAGE	5	PRE-ASSEMBLE THE LEFT SIDE AIR SPRING ASSEMBLY
PAGE	6	PRE-ASSEMBLE THE RIGHT SIDE AIR SPRING ASSEMBLY
PAGE	7	INSTALL FRAME BRACKET & FIT ASSEMBLY
PAGE	8	INSTALL UPPER BRACKET TO FRAME BRACKET
PAGE	9	INSTALL LOWER BRACKET
PAGE	10	AIR LINE TUBE & INFLATION VALVE INSTALLATION
PAGE	11	INSTALL & ROUTE AIR LINE TUBE
PAGE	12	CHECKING THE SYSTEM
PAGE	13	FIXING AN AIR LEAK
PAGE	14	FINISHING THE INSTALLATION

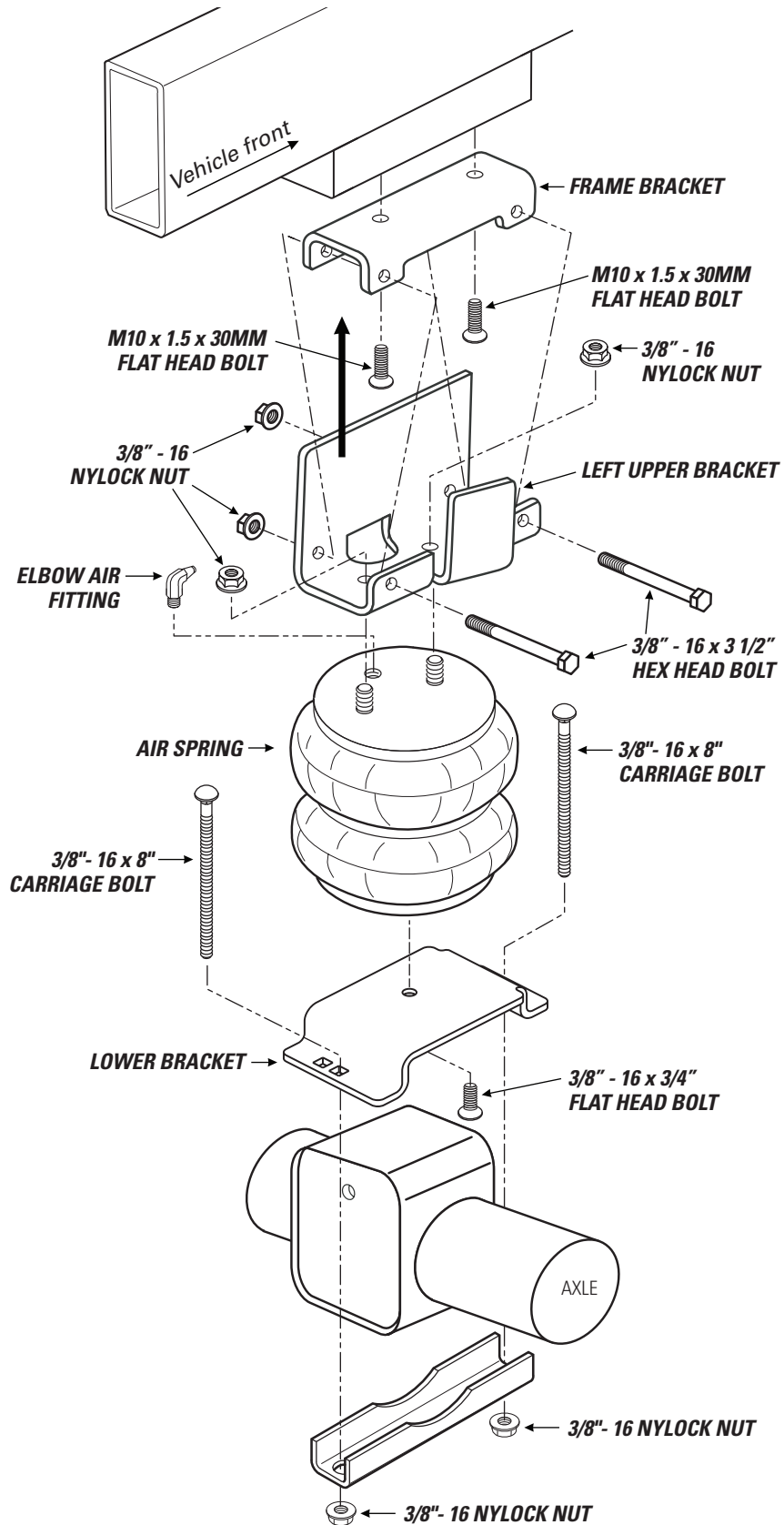



START THE INSTALLATION ON THE LEFT SIDE OF THE VEHICLE WHEN FACING FORWARD.

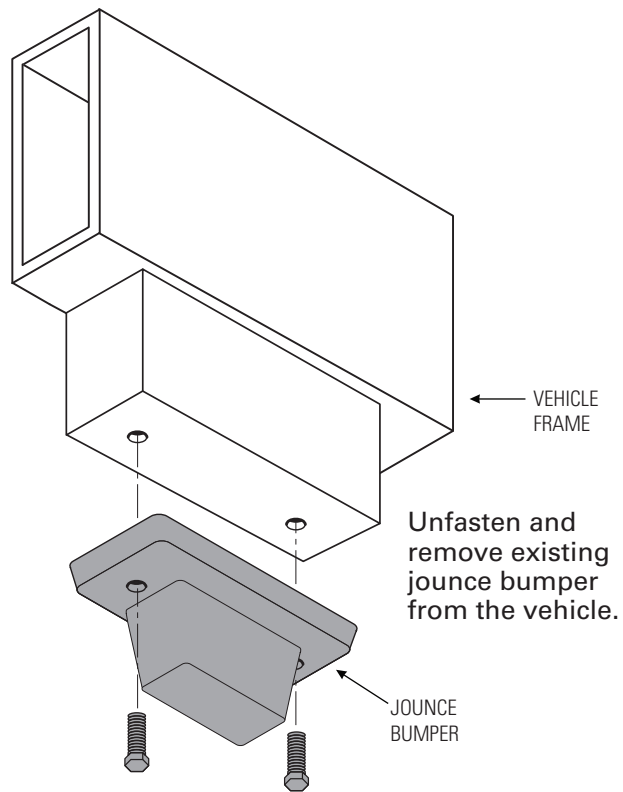

2

PRE-ASSEMBLE THE LEFT SIDE AIR SPRING ASSEMBLY

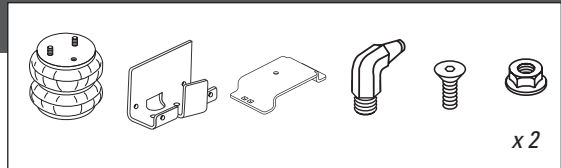

1 Fasten Upper Bracket to Air Spring, as shown.

2 Fasten the Lower Bracket to the Air Spring, hand-tighten only at this step.

3 Note that the Air Fitting should be pointing to the inside of the Upper Bracket.

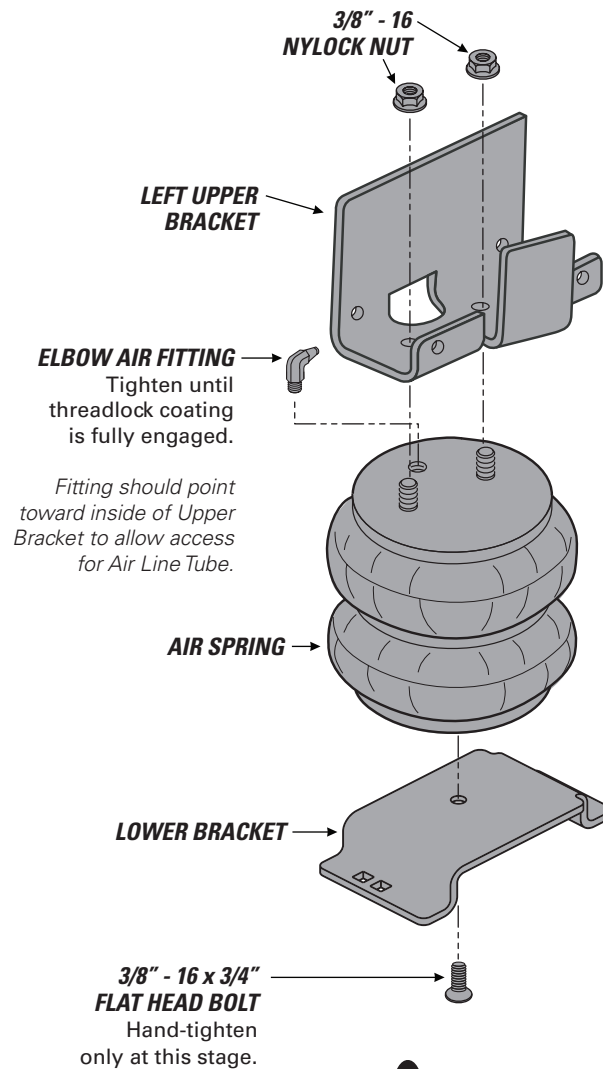

DO NOT FULLY TIGHTEN THE BOLT AT THIS STAGE. TORQUE TO SPEC IN STEP 7.

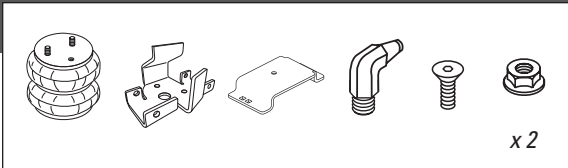

1 Fasten Upper Bracket to Air Spring, as shown.

2 Fasten the Lower Bracket to the Air Spring, hand-tighten only at this step.

3 Note that the Air Fitting should be pointing to the inside of the Upper Bracket.

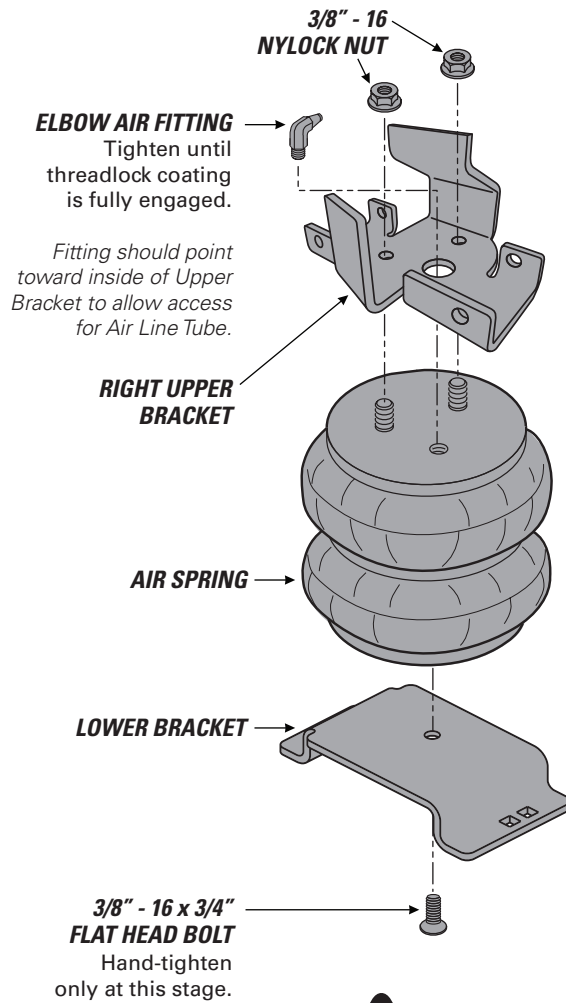

DO NOT FULLY TIGHTEN THE BOLT AT THIS STAGE. TORQUE TO SPEC IN STEP 7.

4

INSTALL THE FRAME BRACKET

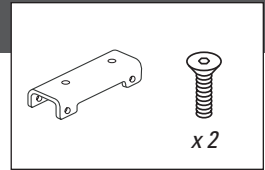

FRAME BRACKET VIEWED FROM BELOW

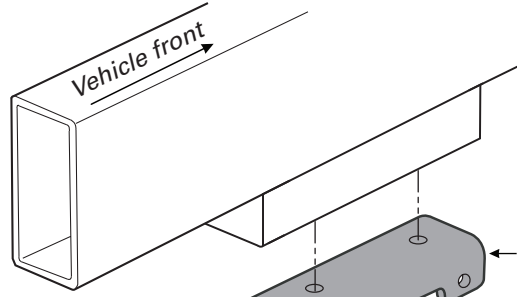
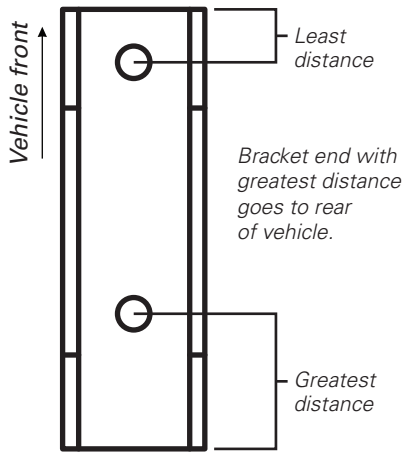

Fasten the Frame Bracket using existing jounce bumper bolt hole locations on vehicle.

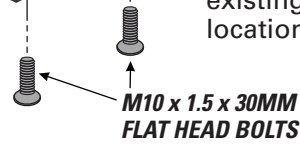

5

FIT AIR SPRING ASSEMBLY INTO PLACE ON FRAME BRACKET

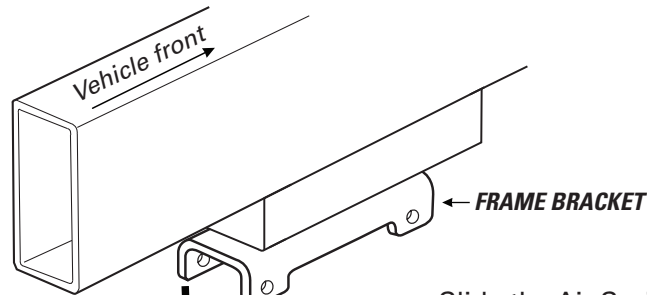

Slide the Air Spring Assembly into place and align the bolt holes in the Frame Bracket with the bolt holes in the Upper Bracket.

Taller side of Upper Bracket goes to the outside of the vehicle frame.

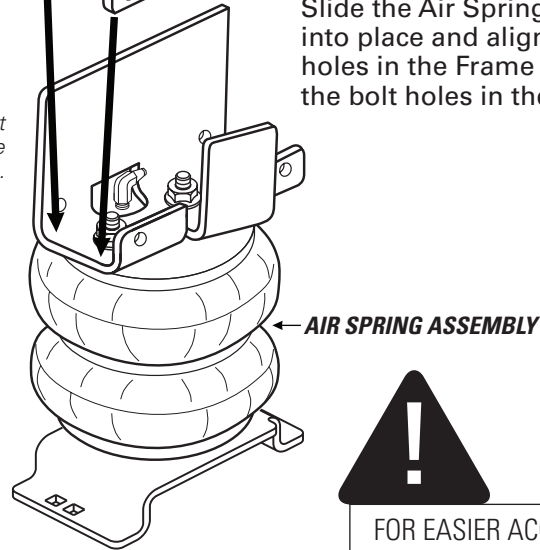

FOR EASIER ACCESS, YOU MAY WANT TO PRE-RUN THE AIR LINE TUBE TO THE AIR FITTING AT THIS STAGE.

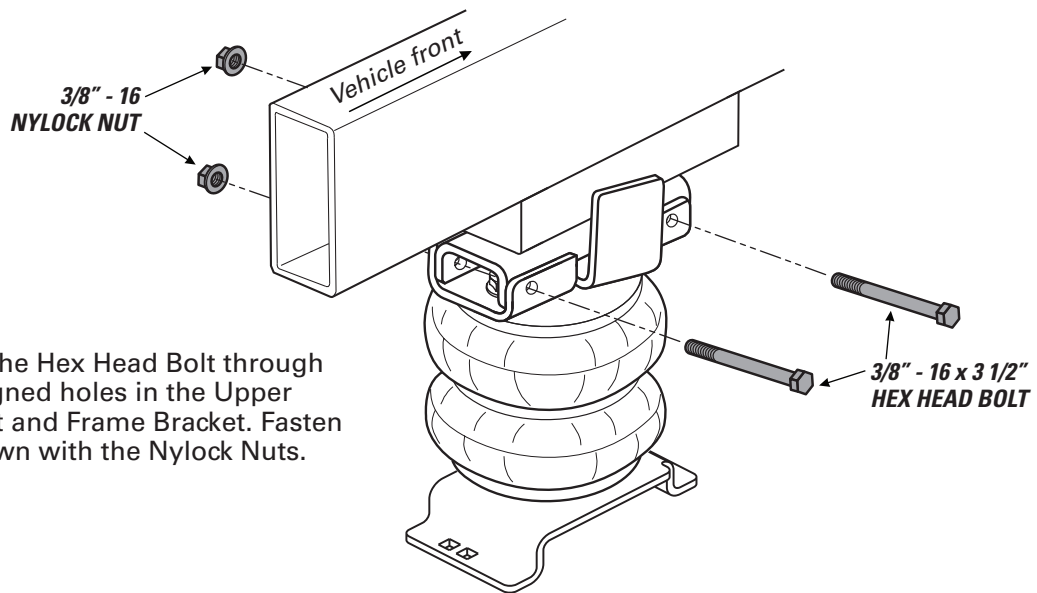
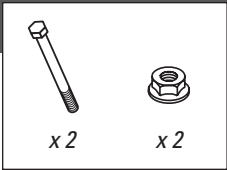

Insert the Hex Head Bolt through the aligned holes in the Upper Bracket and Frame Bracket. Fasten as shown with the Nylock Nuts.

7

INSTALL LOWER BRACKET

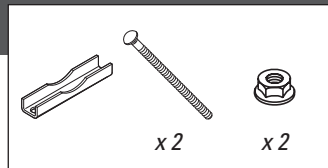

1 Follow guidelines below to dry fit assembly. Make alignment marks as shown.

2 Remove assembly and match alignment marks you made.

3 Fully tighten the 3/8"-16 x 3/4" Flat Head Bolt into the Air Spring.

4 Install the assembly as shown.

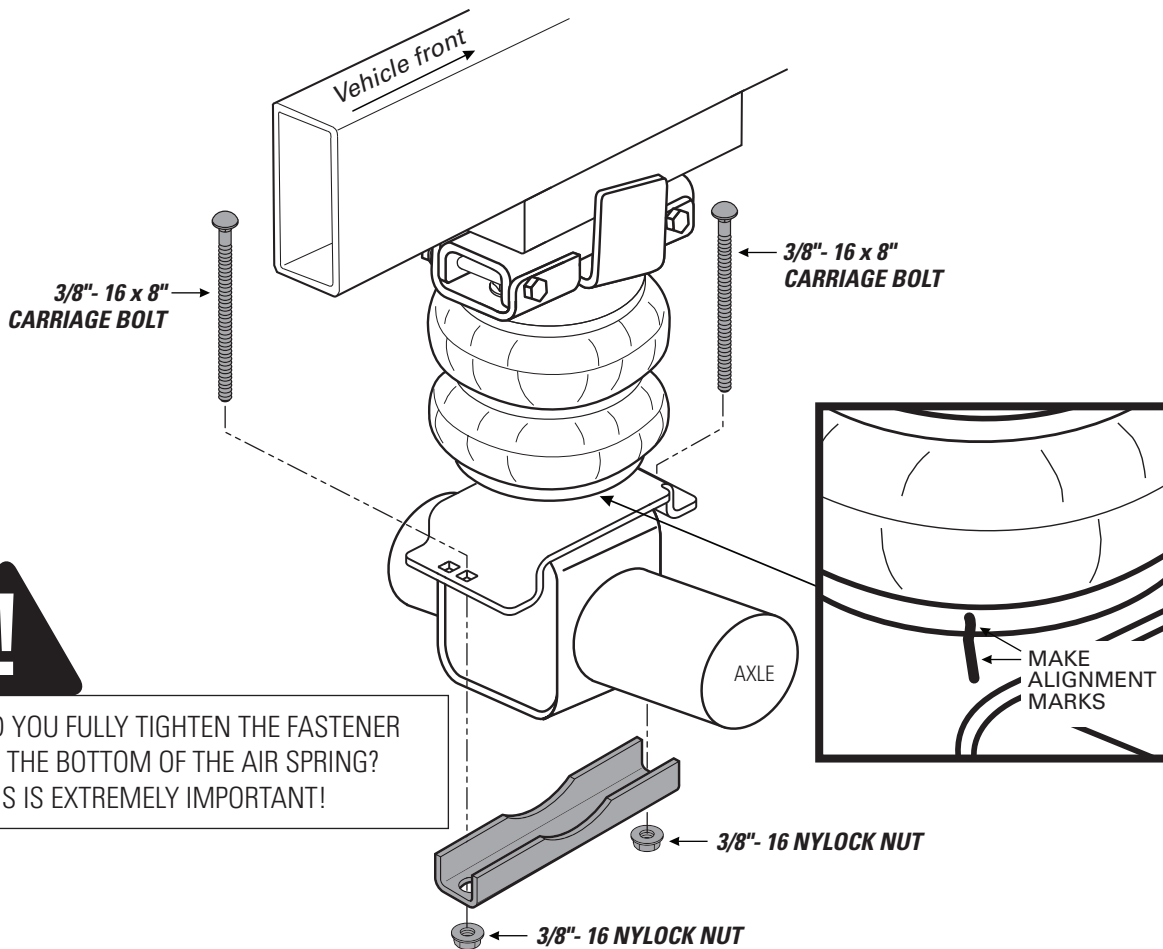

DID YOU FULLY TIGHTEN THE FASTENER ON THE BOTTOM OF THE AIR SPRING? THIS IS EXTREMELY IMPORTANT!



USE YOUR HAND TO CHECK FOR THE PROPER CLEARANCE AROUND THE AIR SPRING. IF YOUR HAND DOES NOT FIT BETWEEN THE AIR SPRING AND OTHER COMPONENTS, IT WILL RUB!



AWESOME! You're done with the left side. The right side uses a different Upper Bracket (shown in Step 3), but the guidelines still apply. Go complete Steps 1-7 for the right side, then continue to Step 10.

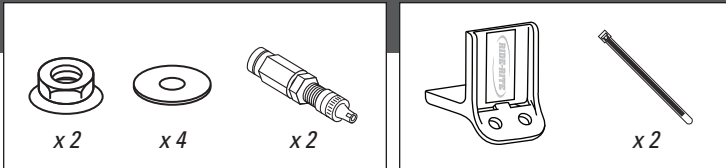

IF USING THE OPTIONAL NO-DRILL INFLATION VALVE BRACKET, CHOOSE OPTION 1. IF DRILLING, CHOOSE OPTION 2. **INFLATION VALVES MUST BE ACCESSIBLE BY AN AIR CHUCK.**

1 Secure the Air Inflation Valve Bracket to a protected, secure location. **PROCEED TO STEP 3.**

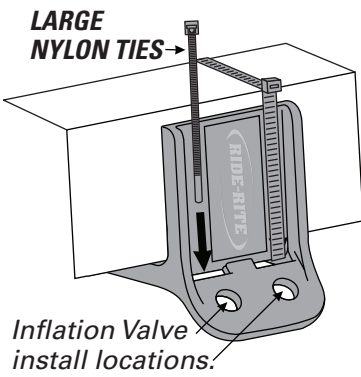

2 Select a protected location to install the Inflation Valves, such as the bumper or the body of the vehicle.

Drill two 5/16" holes for Inflation Valve install locations.

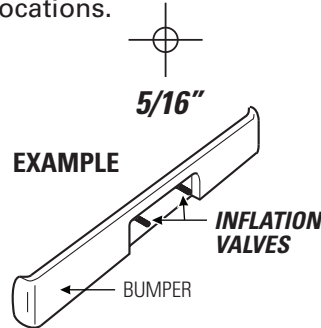

3 Install Inflation Valve assembly as shown.

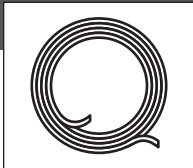
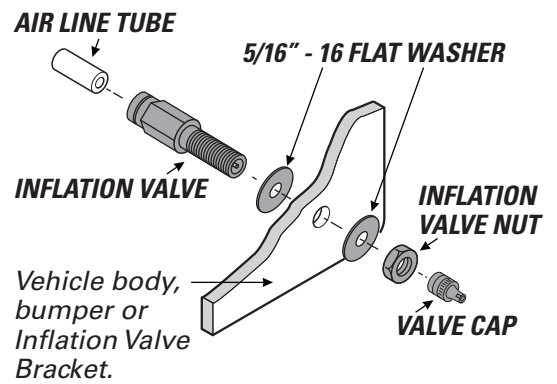

1 Match Air Line Tube ends.



2 Find center of Air Line Tube, make a square cut with tube cutter or sharp utility knife.

DO

Make sure the cut is as square as possible. Use a tube cutter or sharp utility knife.

DON'T

Fold or kink the Air Line Tube. Cut the Air Line Tube at an angle. Use pliers, scissors, snips, saws, or side cutters.

PROPER AND IMPROPER CUTS IN THE AIR LINE TUBE

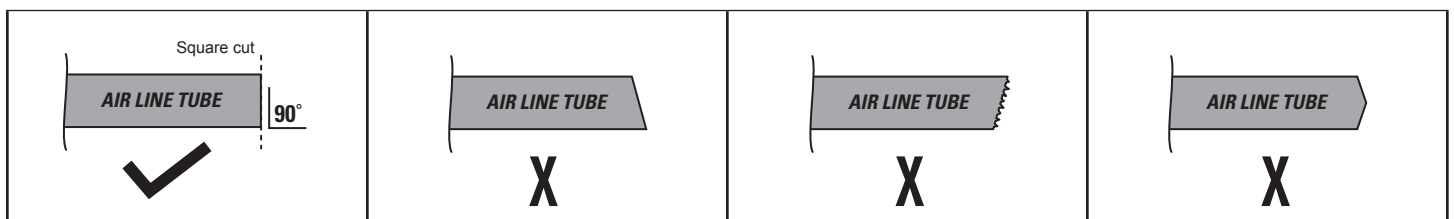

10

INSTALLING AIR LINE TUBE INTO AIR FITTINGS AND INFLATION VALVE

1 Insert end of Air Line Tube into Air Fitting.

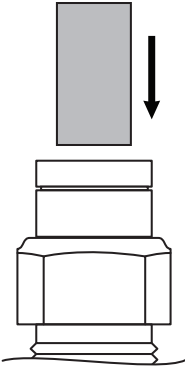

2 Push Air Line Tube into Air Fitting as far as possible.

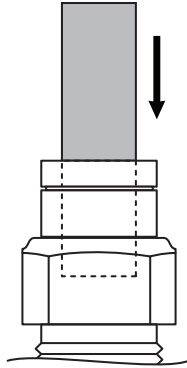

3 Gently pull on the Air Line Tube to check for a secure fit.

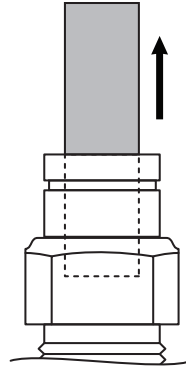

4 To remove, push down collar and gently pull Air Line Tube away.

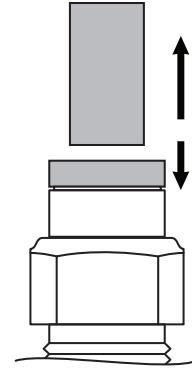

Removal Tip: Use a 1/4", 5/16", or 6mm open-ended wrench to push the collar down.

11

ROUTE AND SECURE AIR LINE TUBES

Air Line Tube routes will vary, depending on your truck, and requires you to choose the best path from the Air Springs to the Inflation Valves. Use the instructions below to help you choose.

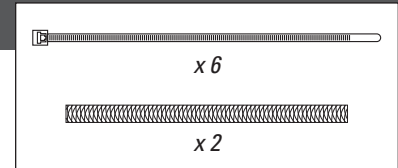

DO

Select routes protected from heat, debris, and sharp edges. Use Thermal Shields near heat sources. Use Nylon Ties to secure the Air Line Tube.

DON'T

Bend or sharply curve Air Line Tubes. Leave Air Line Tube exposed to sharp edges. Use unnecessary lengths of Air Line Tube. Route Air Line Tube near moving parts. Let Air Line tube hang unsecured from vehicle. Scar Air Line Tube while routing.

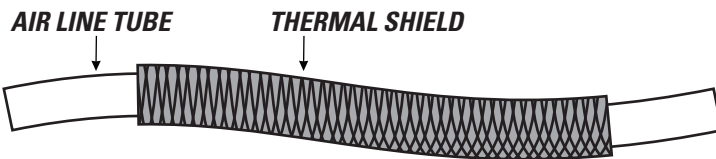

USE SUPPLIED THERMAL SHIELDS WHEN AIR LINE TUBE RUNS **WITHIN 6 INCHES** OF HEAT SOURCES.

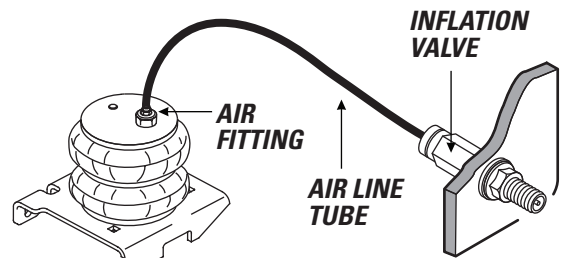

- 1** Place an air chuck onto the Inflation Valve and fill the system to **70 PSI**.

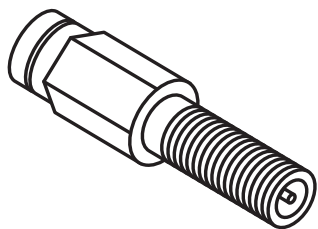

AIR SPRINGS INFLATE QUICKLY. CHECK AIR PRESSURE WHILE INFLATING.

- 2** Spray fittings with soap and water mixture.



- 3** Observe bubbles.

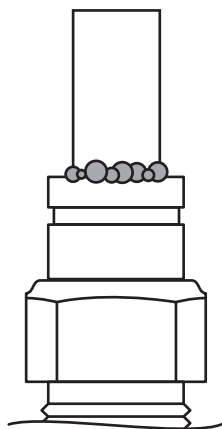

**SMALL SOAP BUBBLES
THAT DO NOT EXPAND**

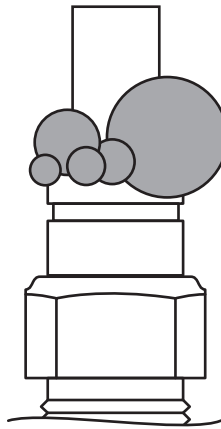

**SOAP BUBBLES
THAT EXPAND**



13

FIXING AN AIR LEAK

- 1 Press the air valve on end of Inflation Valve to release all air pressure.

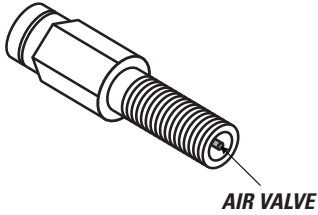

EXHAUST ALL AIR FROM THE SYSTEM PRIOR TO RELEASING AIR LINE TUBES FROM AIR FITTINGS.

LEAK AT AIR LINE TUBE AND AIR FITTING

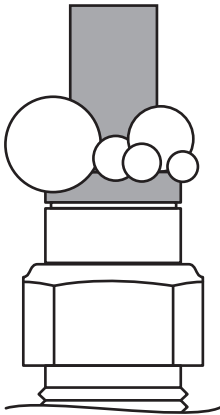

Release Air Line Tube (see page 11). Review proper cuts and procedures in Step 9. Repeat Steps 10 and 12.

LEAK AT BASE OF AIR FITTING ON AIR SPRING

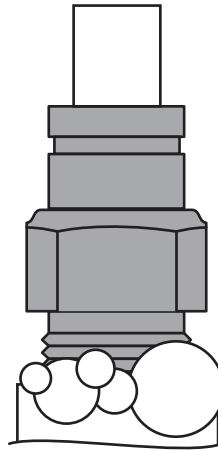

Tighten Air Fitting one turn or until leak stops.

LEAK OUT OF THE VALVE CORE ON INFLATION VALVE

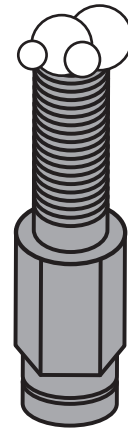

Tighten valve core with valve core wrench on Inflation Valve Cap.

SAFELY RETURN VEHICLE TO OPERATIVE STATE

If you removed any wheels during installation, install the wheels and torque the lug nuts to the manufacturer's specifications.

Safely remove any jack stands and wheel chocks used during installation.

Re-attach the negative battery cable.

DOUBLE-CHECK AIR SPRING CLEARANCE

Check the Air Springs once again for the proper 1/2" minimum clearance. Perform clearance check again when vehicle is under load.

VEHICLE GVWR

NEVER exceed the maximum load recommended by the vehicle manufacturer (GVWR). The GVWR can be found in your vehicle's owner's manual or on the data plate on the driver's side door. Consult your local dealership for additional GVWR specifications.

READ AND UNDERSTAND THE OPERATING INSTRUCTIONS

The Ride-Rite system can improve handling and comfort. Take the time to learn how to properly use and maintain your investment by reading the Operating Instructions.



USE YOUR HAND TO CHECK FOR THE PROPER CLEARANCE AROUND THE AIR SPRING. IF YOUR HAND DOES NOT FIT BETWEEN THE AIR SPRING AND OTHER COMPONENTS, IT WILL RUB!

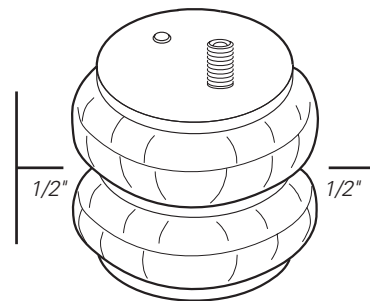

! IMPORTANT

A MINIMUM OF 5 PSI MUST BE MAINTAINED IN THE AIR SPRINGS AT ALL TIMES

Too much air pressure in the Air Springs will result in a firmer ride, while too little air pressure will allow the Air Springs to bottom out over rough conditions, and will not provide the improvement in handling that is possible.

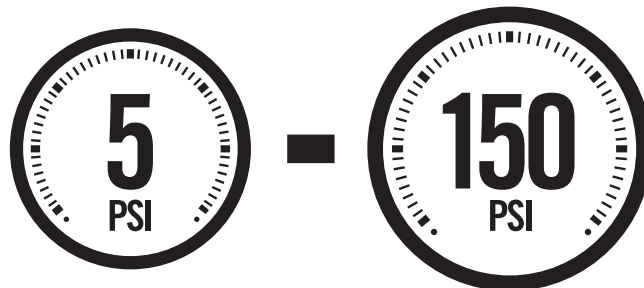

MINIMUM PRESSURE

MAXIMUM PRESSURE (LOADED)



BEFORE YOU DRIVE, CONFIRM THE FOLLOWING:

- Do you have a minimum of 5PSI in your Air Springs?
- Are your Air Springs standing 5 1/2" - 7" tall?
- Are your Air Springs properly aligned, left-to-right and front-to-back?
- Are your nuts and bolts tight?
- Put your paper work back into the sleeve and keep it in your glove compartment for future reference.
- You've been bagged...and now your suspension is Airide™ equipped! Show it off with the supplied decal!

5 1/2" - 7"

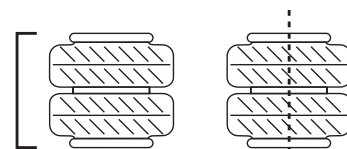

Firestone

World's Number 1
Air Spring.



FIRESTONE INDUSTRIAL PRODUCTS COMPANY