



# INSTALL INSTRUCTIONS FOR: SYSTEM #817844 2018 JEEP WRANGLER JL WITH 3.6L ENGINE

## REVIEW FLOWMASTER SYSTEM:

1. Please take a moment to read and understand these instructions before installing your Flowmaster performance system. Use the parts drawing and list to verify exhaust system contents.

**NOTE:** Some steps in the following instructions may contain two images. The first identifies location of action performed, the second identifies the action performed.

PART NO.	DESCRIPTION	QTY.
15192S	Resonator	1
86505S	Inlet Pipe, Front	1
86506S	Inlet Pipe, Rear	1
815425-515	Muffler	1
PK964	Hardware Pack	1
MC250BS	•2-1/2" Stainless Band Clamp	3
HW502	•7/16" Hanger Keeper 1"	3

## REMOVE STOCK EXHAUST SYSTEM:

**WARNING:**

Avoid serious burns! Allow the exhaust system to cool completely before removing the factory exhaust system.

2. Raise the vehicle up on a hoist or rack to working height. If you don't have access to a hoist or rack, raise the vehicle and support securely with jack stands. Use penetrating lubricant as necessary to ease disassembly.

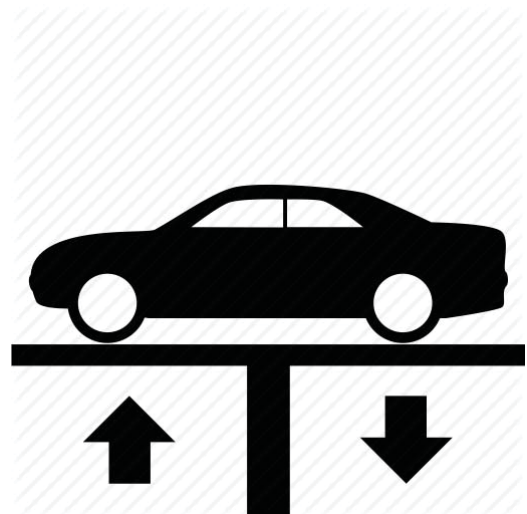

**NOTE:** Use stands as necessary to support parts as you detach them from your vehicle.

3. Remove bolts (x2) from mount on driver side above muffler in area indicated.

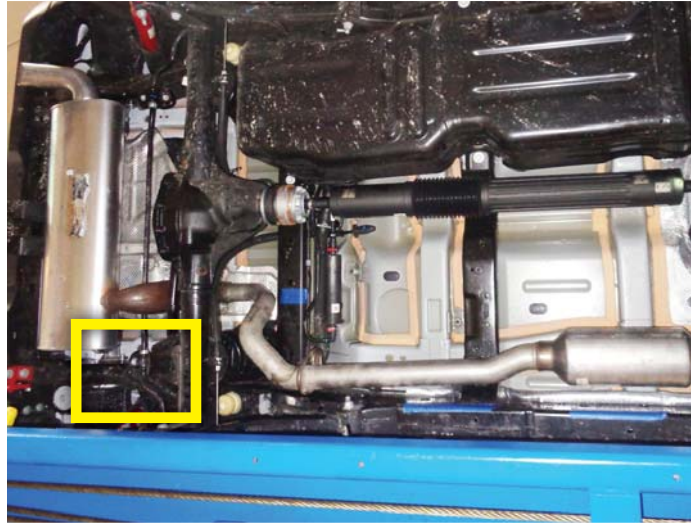

4. Remove bolts (x2) from mount on passenger side above muffler in area indicated.

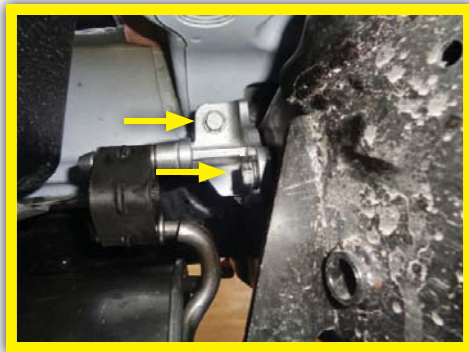

5. Secure and support the muffler, then loosen the clamp at the muffler inlet connection above the rear axle.

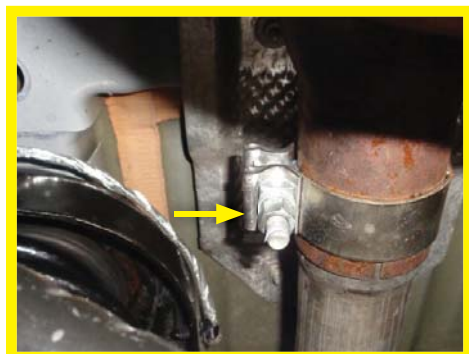

6. Remove muffler from vehicle.



7. Place stock muffler next to Outlaw muffler oriented in the same direction. Then transfer driver and passenger side mounts over to the Outlaw muffler.



8. Remove stock hanger mount with a pry bar and retain for re-use.



9. Remove bolt on clamp at resonator inlet.



10. Remove resonator assembly from vehicle.



11. Remove clamp from resonator inlet and retain for re-use.



## INSTALL FLOWMASTER EXHAUST SYSTEM

12. Remove nuts from stock and Flowmaster clamps, apply anti-seize compound to bolts and re-install nuts.



13. **FOR TWO-DOOR VEHICLES ONLY**, cut 21-1/2" off the rear end of front inlet pipe (86505S).

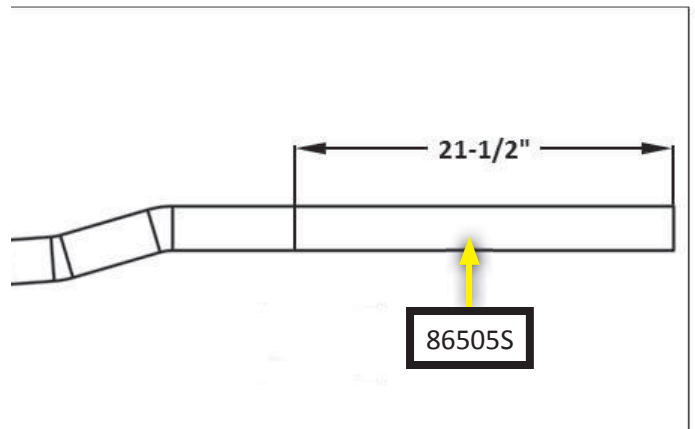

14. Slip the factory clamp over the ball end of the factory pipe, mate the front end of **resonator (151925)** to the factory pipe, then snug the clamp just enough to allow for adjustment.

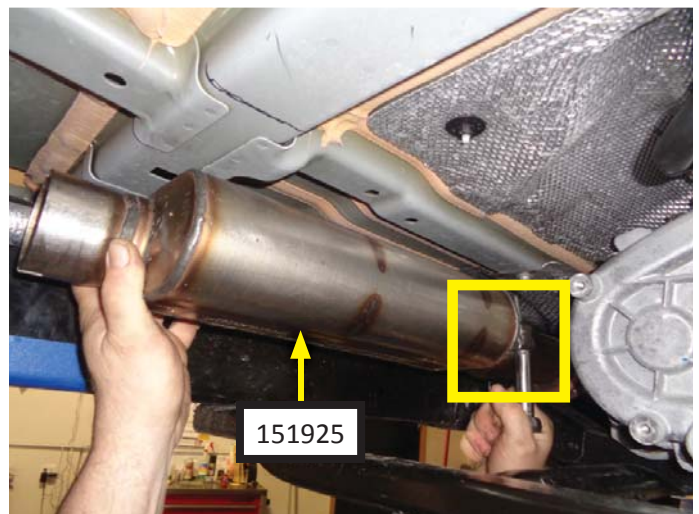
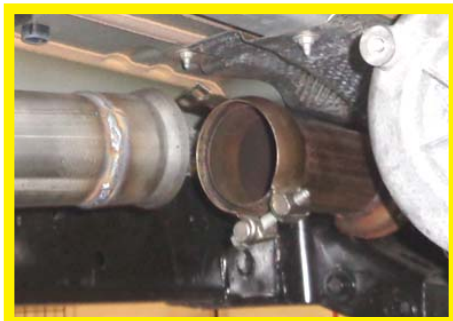

15. Slip a **clamp (MC250BS)** over the front end of **front inlet pipe** then slide the **front inlet pipe** into the back end of the **resonator**. Make sure the bend on the **front inlet pipe** is oriented upwards for maximum clearance. Snug the clamp just enough to allow for adjustment.



16. Slip a clamp (MC250BS) over the front end of rear inlet pipe (86506S), then slide the pipe onto the rear of the front inlet pipe while pushing the pipe's hanger into the rubber mount on the vehicle. Snug the clamp just enough to allow for adjustment.

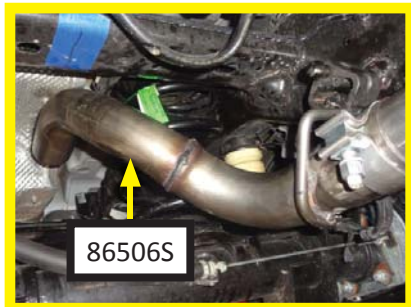

17. Slip a **clamp (MC250BS)** over the muffler inlet of Outlaw muffler. Then slide the muffler inlet over the rear end of rear inlet pipe. Support the muffler, then ensure all connections are completely seated.



18. Place factory (driver and passenger side) hanger mounts into position, then reinstall and tighten the factory bolts.



19. Adjust the position of the muffler and pipes to provide a satisfactory fit. Maintain a minimum of 1/2" clearance around all components of the exhaust system, keeping in mind suspension travel and vibration. After making any required adjustments, securely tighten the clamps.
20. After all clamps are tightened, slide hanger keepers HW502 onto the end of each muffler and pipe hanger, to prevent them from slipping out of the rubber mounts.

Congratulations, the installation of your FLOWMASTER performance exhaust system is now complete!



**NOTE:** Flowmaster maintains a highly trained technical service department to answer your technical questions, provide additional product information and offer various recommendations.





# OUTLAW

S E R I E S

4095® Stainless Steel

Installation diagram for:  
**SYSTEM # 817844**  
**2018 JEEP WRANGLER JL**  
FITS: 3.6L ENGINE

