



*PUNISH THE PAVEMENT!*

PERFORMANCE EXHAUST CATALOG



TM

# FLOWTECH EXHAUST



## NEW & HOT products



2005-06 MUSTANG GT  
TERMINATOR MUFFLER SET  
- Page 24



3" CORE RAPTOR MUFFLER  
- Page 21



DIESEL TRUCK EXHAUST  
SYSTEMS - Page 27



DODGE RAM HEMI HEADERS  
- Page 3



NEW MERCHANDISING  
PRODUCTS  
Flowtech Metal Sign, Banner  
& Decals - Page 40

## HEADERS

3-16

Shorty Smog Headers (Truck) . . . . .	pg. 3	Camaro/Firebird Header Selection Guide . . . . .	pg. 12
Full Length Car Headers . . . . .	pg. 4-7	Block Hugger Headers . . . . .	pg. 13
Full Length Truck Headers . . . . .	pg. 8-9	IMCA Style Race Car Headers . . . . .	pg. 14
Y-Pipes . . . . .	pg. 9	Airmass® Pro-Racing Sport Compact Headers . . . . .	pg. 15
Afterburner™ Turbo Chamber Headers . . . . .	pg. 10	Airmass® Pro-Step™ Sport Compact Headers . . . . .	pg. 16
Mustang 5.0 Header Selection Guide . . . . .	pg. 11		

## MUFFLERS

17-24 & 28

Red Hots™ Mufflers . . . . .	pg. 17	Terminator™ Mufflers . . . . .	pg. 22
Purple Hornies™ Mufflers . . . . .	pg. 18	Mustang Exhaust Systems . . . . .	pg. 23
Warlock™ Mufflers . . . . .	pg. 19	2005-06 Mustang GT Terminator . . . . .	pg. 24
Afterburner™ Mufflers . . . . .	pg. 20	ThunderMuff Sport Compact Muffler . . . . .	pg. 28
Raptor™ Mufflers . . . . .	pg. 21		

## CATBACKS

25-30

Warlock™ Mustang Catbacks . . . . .	pg. 25	Warlock Sport Compact Catbacks . . . . .	pg. 28
Truck Toobs™ . . . . .	pg. 26	ThunderMuff™ Sport Compact Catbacks . . . . .	pg. 29
Diesel Truck Exhaust Systems . . . . .	pg. 27	Super Street Dual Exhaust Kits . . . . .	pg. 30

## H-PIPES & X-PIPES

31-33

Mustang H-Pipes . . . . .	pg. 31		
X-Terminator® Mustang Cross Pipes . . . . .	pg. 32		
Universal Cross-Pipes . . . . .	pg. 33		

## EXHAUST TIPS

34

Terminator Exhaust Tips . . . . .	pg. 34		
Airmass™ Exhaust Tips . . . . .	pg. 34		

## COMPONENTS & ACCESSORIES

35-39

Real-Seal™ Header & Collector Gaskets . . . . .	pg. 35	Thrust Tubes, Flanged Turnouts, Reducers/Street Hookups . . . . .	pg. 38
Replacement Header & Collector Gaskets . . . . .	pg. 36	Do-It-Yourself Components . . . . .	pg. 39
Race Readies™ Exhaust Cut-Outs . . . . .	pg. 37		

Merchandising - Banners, Decals, Metal Signs . . . . .	pg. 40	Part # to Page Index . . . . .	pg. 47-48
Header Photo Gallery . . . . .	pg. 41-46		

Holley and other manufacturers have developed a program whereby all emission-sensitive products can be identified by placing color-coded, numbered labels on product packaging and listing corresponding numeric codes next to each part number. The color codes (corresponding numbers) and explanations are as follows:



The product accompanying this document has been granted a California Air Resources Board (CARB) exemption, an "EO" number, or is a direct or consolidated replacement part. It is 50-state legal, per the manufacturer's application guide.



The manufacturer of the product accompanying this document represents that it has not been found, nor is believed to be, unlawful for use under provisions of the Clean Air Act, per the manufacturer's application guide. This product is **not legal** for sale or use in the State of California (or in states which have adopted California emission standards) except on pre-emission-controlled motor vehicles/motor vehicle engines (pre-1966 model year).



The product accompanying this document is legal **only** for off-highway use (except in California or states that have adopted California emission standards), racing use or for use on pre-emission-controlled motor vehicles/motor vehicle engines (pre-1966 domestic vehicles certified to California standards, pre-1968 domestic vehicles certified to federal standards and all pre-1968 foreign vehicles), per the manufacturer's application guide.

## Emission Compatible "Shorty" Headers Provide Maximum Horsepower!

FLOWTECH's emissions-friendly headers are just the ticket for those who want the best of both worlds – top performance and a clean machine. All Shorty Smog Headers bolt on quickly and easily to the factory exhaust system, retaining all stock emissions equipment, and offering maximum horsepower gains plus increased efficiency!

- Extra-thick 3/8" flanges for a leak free seal
- 16-gauge tubing for durability
- Connects to factory exhaust head pipe
- Complete with premium gaskets and hardware



**TIP:** Breaking in an engine with ceramic coated headers WILL result in damage to the coating and will VOID all warranties. Ceramic coated headers require several heat cycles to fully cure before they will withstand extreme heat. Flowtech recommends using cast iron exhaust manifolds or old headers to break in new engines to avoid coating damage. Please call Flowtech tech service at 270-781-9741 for additional information regarding ceramic coated exhaust products.

APPLICATION	YEAR	ENGINE	FLOWTECH I™ STANDARD	FLOWTECH II™ CERAMIC	PRI TUBE COL SIZE	TRANSMISSION		FOOTNOTES				
						AC	COL FLR		STD	COL FLR		
<b>FLOWTECH EMISSIONS FRIENDLY HEADERS</b>												
<b>CHEVROLET/GMC - TRUCK 2 &amp; 4 WD</b>												
1500,2500 PU	88-95	5.0/5.7L	91830FLT	91830-1FLT	1-1/2" OE	Y	Y	Y	Y	Y	8,53,100,111, 99	3
1500,2500 A.I.R.	88-95	5.0/5.7L	91831FLT	-	1-1/2" OE	Y	Y	Y	Y	Y	2,53,100,111, 99	3
1500,2500 PU	96-99	5.7L	91832FLT	91832-1FLT	1-1/2" OE	Y	Y	Y	Y	Y	53,100, 99	3
SUBURBAN	92-95	5.7L	91830FLT	91830-1FLT	1-1/2" OE	Y	Y	Y	Y	Y	8,53,100,111, 99	3
SUBURBAN w/ A.I.R.	92-95	5.7L	91831FLT	-	1-1/2" OE	Y	Y	Y	Y	Y	2,53,100,111, 99	3
SUBURBAN	96-97	5.7L	91832FLT	91832-1FLT	1-1/2" OE	Y	Y	Y	Y	Y	53,100, 99	3
BLAZER/JIMMY	92-94	5.0/5.7L	91830FLT	91830-1FLT	1-1/2" OE	Y	Y	Y	Y	Y	8,53,100,111, 99	3
BLAZER/JIMMY w/ A.I.R.	92-94	5.0/5.7L	91831FLT	-	1-1/2" OE	Y	Y	Y	Y	Y	2,53,100,111, 99	3
TAHOE, YUKON	1995	5.7L	91830FLT	91830-1FLT	1-1/2" OE	Y	Y	Y	Y	Y	8,53,99,111, 99	3
TAHOE, YUKON	96-97	5.7L	91832FLT	91832-1FLT	1-1/2" OE	Y	Y	Y	Y	Y	53,100, 99	3
SIERRA/SILVERADO	99-02	4.8L/5.3L	91834FLT	91834-1FLT	1-5/8" OE	Y	Y	Y	Y	Y	8,53,99,255	3
SIERRA/SILVERADO/SUBURBAN/ YUKON/ESCALADE	99-02	6.0L	91835FLT	91835-1FLT	1-5/8" OE	Y	Y	Y	Y	Y	53,99,255	3
SIERRA/SILVERADO	02-04	4.8L/5.3L	91836FLT	91836-1FLT	1-5/8" OE	Y	Y	Y	Y	Y	53,99,254	3
TAHOE/SUBURBAN/YUKON/ AVALANCHE/ESCALADE	02-06	4.8L/5.3L	91836FLT	91836-1FLT	1-5/8" OE	Y	Y	Y	Y	Y	53,99,254	3
GM PU/TAHOESUBURBAN/YUKON/ESCALADE	98-00	5.7L	91837FLT	91837-1FLT	1-5/8" OE	Y	Y	Y	Y	Y	2,53,99	3
<b>DODGE - TRUCK 2 &amp; 4 WD</b>												
DAKOTA/RAM	92-95	5.2/5.9L	91940FLT	91940-1FLT	1-1/2" OE	Y	Y	Y	Y	Y	53,100, 99	3
DAKOTA/DURANGO/RAM	96-03	5.2L/5.9L	91945FLT	91945-1FLT	1-1/2" OE	Y	Y	Y	Y	Y	53,100, 99	3
DAKOTA/DURANGO	00-03	4.7L	91944FLT	91944-1FLT	1-1/2" OE	Y	Y	Y	Y	Y	53,100, 99	3
RAM 1500	2003		91941FLT	91941-1FLT	1-1/2" OE	Y	Y	Y	Y	Y	53,100, 99	3
RAM 1500	04-05		91946FLT	91946-1FLT	1-1/2" OE	Y	Y	Y	Y	Y	53,100, 99	3
RAM 2500/3500	2003		91947FLT	91947-1FLT	1-1/2" OE	Y	Y	Y	Y	Y	53,100, 99	3
RAM 2500/3500	04-05		91948FLT	91948-1FLT	1-1/2" OE	Y	Y	Y	Y	Y	53,100, 99	3
<b>FORD - TRUCK 2 &amp; 4 WD</b>												
F150/250, BRONCO	87-95	5.0L	91627FLT	91627-1FLT	1-1/2" OE	Y	Y	Y	Y	Y	53,100, 99	3
F150/250, BRONCO	86-95	5.8L	91628FLT	91628-1FLT	1-1/2" OE	Y	Y	Y	Y	Y	53,100, 99	3
F150/250, BRONCO	1996	5.8L	91668FLT	91668-1FLT	1-1/2" OE	Y	Y	Y	Y	Y	53,100, 99	3
FORD EXPEDITION, F-SERIES	97-02	5.4L	91669FLT	91669-1FLT	1-1/2" OE	Y	Y	Y	Y	Y	53,99,249	3
FORD EXPEDITION, F-SERIES	97-02	4.6L	91670FLT	91670-1FLT	1-1/2" OE	Y	Y	Y	Y	Y	53,99,249	3
<b>TOYOTA - TRUCK 2 &amp; 4 WD</b>												
TUNDRA/SEQUOIA	00-04	4.7L V8	91730FLT	91730-1FLT	1-1/2" OE	Y	Y	Y	Y	Y	53,100, 99	3

### INSTALLATION NOTES

Y = YES, N = NO, O = NOT VERIFIED

- 2 THESE HEADERS ARE A.I.R. COMPATIBLE.
- 8 Will not fit with A.I.R. injection pump.
- 53 Stock replacement, bolts directly to factory headpipes.
- 99 49 states emissions legal, California E.O. pending.
- 100 Will work with factory exhaust system.

- 111 Fits application where driver's side manifold has its exit rear of the rear-most exhaust port.
- 249 will not fit super duty model
- 254 with out E.G.R
- 255 with E.G.R

# FULL LENGTH HEADERS

## HEADERS



### Standard Full Length Headers

FLOWTECH headers are precision engineered and leak tested to get maximum performance and fuel economy from your engine. Each header is formed from specially selected .060 cold roll flash controlled tubing, and features FLOWTECH's exclusive, thick, mandrel-formed Power Plenum™ collector. All ports are precisely fitted and finished with sturdy, leak-proof O-ringed port seals, and all FLOWTECH headers include all mounting hardware including bolts, nuts and premium gaskets. FLOWTECH headers are available with either a high-quality, electrostatically-applied satin black paint finish or with a specially formulated, NASA®-developed silver luster ceramic coating for rust and corrosion resistance.

- Mandrel-formed Power Plenum collectors for low backpressure
- Constructed of .060 cold roll flash mild steel tubing
- Precision engineered for fit, performance and economy
- Includes all mounting hardware and premium gaskets



31100FLT

### Late Model Full Length Headers

Flowtech value now available for late model 4.6L Mustangs and LS1 Camaro/Firebird

- Tuned length for a broad power curve
- Bolt up collector flanges for ease of installation
- Mandrel bent tubing for low backpressure
- Constructed of .060" cold roll tubing
- 5/16" flanges for a perfect seal
- Includes all hardware and gaskets for ease of installation
- Certain applications include O<sub>2</sub> extension harnesses





# FULL LENGTH HEADERS

## HEADERS

APPLICATION	YEAR	ENGINE	FLOWTECH I™ STANDARD	FLOWTECH II™ CERAMIC	PRI TUBE COL SIZE	AC	TRANSMISSION				FOOTNOTES
							AUTO		STD		
							COL	FLR	COL	FLR	
<b>FLOWTECH HEADERS</b>											
<b>BUICK</b>											
REGAL	78-87	283-400	11102FLT	31102FLT	1-1/2"x2-1/2"	Y	N	Y	N	Y	1,3,4,54,58,66,90
<b>CHEVROLET</b>											
CAMARO	67-69	283-400	11100FLT	31100FLT	1-5/8"x3"	12	Y	Y	N	Y	32
CAMARO	67-81	283-400	11108FLT	31108FLT	1-1/2"x2-1/2"	23	Y	Y	N	N	3,12,14,15,54
CAMARO	70-81	283-400	11100FLT	31100FLT	1-5/8"x3"	23	Y	Y	N	Y	3,6,31,58
CAMARO	82-91	283-400	11102FLT	31102FLT	1-1/2"x2-1/2"	Y	N	Y	N	Y	3,54,58,66,90,249
CAMARO	67-69	396-454	11132FLT	31132FLT	1-7/8"x3-1/2"	Y	Y	Y	N	Y	
CAMARO	70-72	396-454	11130FLT	31130FLT	1-3/4"x3"	Y	N	Y	N	Y	
CAMARO Z/28**	82-89	305	11114FLT	31114FLT	1-1/2"x2-1/2"	Y	N	Y	N	Y	54,103,104,105
CAMARO Z/28**	82-92	305-350	11116FLT	31116FLT	1-1/2"x2-1/2"	Y	N	Y	N	Y	54,104,66
CAMARO	98-99	LS1	11133FLT	11133-1FLT	1-3/4"x3"	Y	N	Y	N	Y	66,234,236,248
CAMARO	00-02	LS1	11134FLT	11134-1FLT	1-3/4"x3"	Y	N	Y	N	Y	66,234,236,248
Y-PIPE FOR 11133FLT & 11134FLT			11133YFLT	11133Y-1FLT							247
CHEVELLE	64-77	283-400	11100FLT	31100FLT	1-5/8"x3"	Y	Y	Y	Y	Y	32
CHEVELLE	68-87	283-400	11108FLT	31108FLT	1-1/2"x2-1/2"	23	Y	Y	N	N	3,14,15,54
*CHEVELLE	78-87	283-400	11102FLT	31102FLT	1-1/2"x2-1/2"	Y	Y	Y	N	Y	1,3,54,66,90,249
CHEVELLE	78-87	283-400	11104FLT	31104FLT	1-5/8"x3"	23	Y	Y	N	N	3,6
CHEVELLE	64-74	396-454	11130FLT	31130FLT	1-3/4"x3"	Y	N	43	N	Y	3
CHEVELLE(El Camino)**	78-87	305	11114FLT	31114FLT	1-1/2"x2-1/2"	Y	Y	Y	N	Y	6,54,102,103,104,105
CHEVY II/NOVA	64-67	283-400	11110FLT	31110FLT	1-1/2"x3"	23	N	Y	N	Y	8,10
CHEVY II/NOVA	68-79	283-400	11108FLT	31108FLT	1-1/2"x2-1/2"	N	Y	Y	N	N	3,14,54
CHEVY II/NOVA	68-79	283-400	11100FLT	31100FLT	1-5/8"x3"	Y	Y	Y	Y	Y	3,32,58
CHEVY II/NOVA	68-74	396-454	11132FLT	31132FLT	1-7/8"x3-1/2"	Y	Y	Y	Y	Y	8
CORVETTE	63-82	283-400	11106FLT	31106FLT	1-5/8"x3"	23	N	Y	N	Y	3
MONTE CARLO	70-77	305-400	11100FLT	31100FLT	1-5/8"x3"	Y	Y	Y	N	N	3,58
MONTE CARLO	70-87	283-400	11108FLT	31108FLT	1-1/2"x2-1/2"	23	Y	Y	N	N	3,14,15,54
MONTE CARLO	78-87	283-400	11104FLT	31104FLT	1-5/8"x3"	Y	Y	Y	N	Y	3,6
MONTE CARLO SS**	83-88	305-350	11116FLT	31116FLT	1-5/8"x3"	23	Y	Y	N	N	6,54,102,104,66
PASSENGER	55-57	265-400	11112FLT	31112FLT	1-5/8"x3"	N	Y	Y	Y	Y	58,80
PASSENGER	65-70	283-400	11100FLT	31100FLT	1-5/8"x3"	Y	Y	Y	Y	Y	32,58
PASSENGER	71-77	283-400	11100FLT	31100FLT	1-5/8"x3"	Y	Y	Y	N	N	3
PASSENGER	71-91	283-400	11108FLT	31108FLT	1-1/2"x2-1/2"	23	Y	Y	N	N	3,14,15,54
PASSENGER	78-89	305-400	11100FLT	31100FLT	1-5/8"x3"	23	Y	Y	N	N	3,6,58
PASSENGER	65-70	396-454	11132FLT	31132FLT	1-7/8"x3-1/2"	Y	Y	Y	Y	Y	
PASSENGER	71-74	396-454	11130FLT	31130FLT	1-3/4"x3"	Y	N	Y	N	Y	
<b>DODGE/PLYMOUTH</b>											
ASPEN	76-79	273-360	13100FLT	33100FLT	1-5/8"x3"	Y	Y	Y	Y	Y	3,8,22,240
BARRACUDA	67-74	273-360	13100FLT	33100FLT	1-5/8"x3"	Y	Y	Y	Y	Y	8,22,240
BARRACUDA	70-74	361-440	13130FLT	33130FLT	1-3/4"x3"	Y	Y	Y	42	42	24,240
BELVEDERE	67-76	273-360	13100FLT	33100FLT	1-5/8"x3"	Y	Y	Y	Y	Y	3,8,22,240
BELVEDERE	67-74	361-440	13130FLT	33130FLT	1-3/4"x3"	Y	Y	Y	42	42	24,240
CHALLENGER	70-77	273-360	13100FLT	33100FLT	1-5/8"x3"	Y	Y	Y	Y	Y	3,8,22,240
CHALLENGER	70-74	361-440	13130FLT	33130FLT	1-3/4"x3"	Y	Y	Y	42	42	24,240
CHARGER	66-77	273-360	13100FLT	33100FLT	1-5/8"x3"	Y	Y	Y	Y	Y	3,8,22,240

INSTALLATION NOTES		Y = YES, N = NO, O = NOT VERIFIED	
1	Also available with A.I.R. injection manifold welded in place. Add suffix "S" to the part number when ordering (Not available with ceramic finish headers).	53	Stock replacement, bolts directly to factory headpipes.
3	Must modify stock exhaust to retain catalytic converters.	54	Shorty-style header, will also work on catalytic equipped vehicles. Head pipe fabrication required.
4	Not legal for use on pollution controlled motor vehicles. Legal only for racing vehicles that will never be driven upon a highway. If you have any questions please contact your FLOWTECH dealer.	58	Will not fit angle plug heads.
5	Can be modified to fit A.I.R. fittings in head.	66	Header is equipped with an oxygen sensor fitting
6	Applications with oxygen sensor use reducer #10105 for 2-1/2" 3-bolt flange or #10110 for 3" 3-bolt flange.	67	Will not fit C5 Transmission
8	Will not fit with A.I.R. injection pump.	80	Will not fit convertible models
10	Fits factory OEM 64-67 transmissions only.	99	49 states emissions legal, California E.O. pending
12	Will not fit 67-69 Camaro with air conditioning.	100	Will work with factory exhaust system
14	Will fit angle plug heads, factory Chevy aluminum only.	101	Will not fit 400C
31	Must modify lower A-Arm support bracket on 79-81 models.	102	Modification to stock exhaust required to retain stock catalytic converter
32	Pre-70 vehicles with exhaust manifold mounted Alternator/Generator use bracket #10031.	103	On 1987 models, this header will only fit
15	Must modify rotary air conditioning bracket.	104	Will fit Dart Sportsman II angle plug heads
20	Power steering equipped use bracket #10041 for installation.	105	Fitting for exhaust gas temperature sensor is welded to header. If needed, hole must be drilled thru header tube
22	It may be necessary to raise the automotive column cross shaft linkage by rotating the mounting brackets on frame and transmission 180 degrees.	234	Aluminized "Y" pipes that bolt to factory and aftermarket cat-backs is available under part# 11133YFLT
23	Installation requires Flowtech air conditioning bracket #10042FLT. 1979 and later vehicles equipped with short compressor, use original bracket.	236	Includes oxygen sensor extension harness(s)
24	Will not fit 440 6-pack 4-speed With 13" flywheel.	240	Will not fit vehicles with power steering
42	May require clutch linkage modifications.	247	"Y" pipe is designed to bolt to either 11133FLT or 11134FLT
43	Will not fit with Powerglide Transmission.	248	Aluminized "Y" pipe that bolts to factory and aftermarket cat-back is available under p/n 11133Y-FLT
		249	With A.I.R.
		**	Short design

EO HEADERS  
FULL LENGTH HEADERS  
BLOCK HUGGER HEADERS  
RACE HEADERS  
IMPORT HEADERS  
GLASS BACK MUFFLERS  
TURBO-STYLE MUFFLERS  
IMPORT MUFFLERS  
CATBACKS  
H-PIPES & X-PIPES  
TIPS  
COMPONENTS & ACCESSORIES  
MERCHANDISING  
PHOTO GALLERY PART # INDEX

# FULL LENGTH HEADERS

## HEADERS



APPLICATION	YEAR	ENGINE	FLOWTECH I™ STANDARD	FLOWTECH II™ CERAMIC	PRI TUBE COL SIZE	AC	TRANSMISSION				FOOTNOTES	
							AUTO COL	FLR	STD COL	FLR		
<b>DODGE/PLYMOUTH - (cont'd)</b>												
CHARGER	67-74	361-440	13130FLT	33130FLT	1-3/4"x3"	Y	Y	Y	42	42	24,240	3
CORONET	67-76	273-360	13100FLT	33100FLT	1-5/8"x3"	Y	Y	Y	Y	Y	8,22,240	3
CORONET	67-74	361-440	13130FLT	33130FLT	1-3/4"x3"	Y	Y	Y	42	42	24,240	3
CUDA	70-74	273-360	13100FLT	33100FLT	1-5/8"x3"	Y	Y	Y	Y	Y	53,99,100	2
CUDA	70-74	361-440	13130FLT	33130FLT	1-3/4"x3"	Y	Y	Y	42	42	53,99,100	2
DART	67-76	273-360	13100FLT	33100FLT	1-5/8"x3"	Y	Y	Y	Y	Y	8,22,240	3
DEMON	70-76	273-360	13100FLT	33100FLT	1-5/8"x3"	Y	Y	Y	Y	Y	3,8,22,240	3
DUSTER	70-76	273-360	13100FLT	33100FLT	1-5/8"x3"	Y	Y	Y	Y	Y	3,8,22,240	3
GTX, R/T	67-76	273-360	13100FLT	33100FLT	1-5/8"x3"	Y	Y	Y	Y	Y	3,8,22,240	3
GTX, R/T	67-74	361-440	13130FLT	33130FLT	1-3/4"x3"	Y	Y	Y	42	42	24,240	3
ROAD RUNNER	67-78	273-360	13100FLT	33100FLT	1-5/8"x3"	Y	Y	Y	Y	Y	3,8,22,240	3
ROAD RUNNER	67-74	361-440	13130FLT	33130FLT	1-3/4"x3"	Y	Y	Y	42	42	24,240	3
SATELLITE	67-76	273-360	13100FLT	33100FLT	1-5/8"x3"	Y	Y	Y	Y	Y	3,8,22,240	3
SATELLITE	67-74	361-440	13130FLT	33130FLT	1-3/4"x3"	Y	Y	Y	42	42	24,240	3
SUPER BEE	67-74	273-360	13100FLT	33100FLT	1-5/8"x3"	Y	Y	Y	Y	Y	8,22,240	3
SUPER BEE	67-74	361-440	13130FLT	33130FLT	1-3/4"x3"	Y	Y	Y	42	42	24,240	3
VALIANT	67-69	273-360	13100FLT	33100FLT	1-5/8"x3"	Y	Y	Y	Y	Y	8,22,240	3
VOLARE	76-81	273-360	13100FLT	33100FLT	1-5/8"x3"	Y	Y	Y	Y	Y	3,8,22,240	3
<b>FORD</b>												
FAIRLANE	66-73	260-302W	12100FLT	32100FLT	1-1/2"x3"	Y	Y	Y	N	N	5,20,67	3
FAIRLANE	70-74	351C-4V	12118FLT	32118FLT	1-3/4"x3"	Y	Y	Y	N	N	20,67,101	3
FALCON	66-67	260-302W	12100FLT	32100FLT	1-1/2"x3"	Y	Y	Y	N	Y	5,20,67	3
MUSTANG	64-70	260-302W	12102FLT	32102FLT	1-1/2"x3"	Y	N	Y	N	Y	5,20	3
MUSTANG	71-73	260-302W	12100FLT	32100FLT	1-1/2"x3"	Y	N	Y	N	N	5,20,67	3
MUSTANG	70-74	351C-4V	12118FLT	32118FLT	1-3/4"x3"	Y	Y	Y	N	N	20,67,101	3
MUSTANG	69-73	351W	12100FLT	32100FLT	1-1/2"x3"	Y	N	Y	N	N	5,20,67	3
MUSTANG	79-93	302W	12104FLT	32104FLT	1-5/8"x3"	Y	N	Y	N	Y	3,66,70,71	3
MUSTANG GT/LX	86-93	302W	12106FLT		1-1/2"xOE	Y	N	Y	N	Y	53	2
MUSTANG GT/LX	86-93	302W	12107FLT	32107FLT	1-5/8"xOE	Y	N	Y	N	Y	53	2
MUSTANG GT/LX	86-93	302W	12110FLT	32110FLT	1-5/8"xOE	Y	N	Y	N	Y	61,70,71	3
MUSTANG	94-95	302W	12112FLT	32112FLT	1-5/8"xOE	Y	N	Y	N	Y	53	3
MUSTANG	96-03	4.6L 4V	12114FLT	12114-1FLT	1-5/8 x3"	Y	N	Y	N	Y	236,251	3
			12114YFLT								252	3
MUSTANG	96-02	4.6L 2V	12115FLT	12115-1FLT	1-5/8 x3"	Y	N	Y	N	Y	236,250	3
			12115YFLT								253	3
RANCHERO	66-73	260-302W	12100FLT	32100FLT	1-1/2"x3"	Y	Y	Y	N	N	5,20,67	3
RANCHERO	70-73	351C-4V	12118FLT	32118FLT	1-3/4"x3"	Y	Y	Y	N	N	20,67,101	3
TORINO	68-73	260-302W	12100FLT	32100FLT	1-1/2"x3"	Y	Y	Y	N	N	5,20,67	3
TORINO	70-73	351C-4V	12118FLT	32118FLT	1-3/4"x3"	Y	Y	Y	N	N	20,67,101	3

### INSTALLATION NOTES

Y = YES, N = NO, O = NOT VERIFIED

- |   |  |
|---|--|
| <p>1 Also available with A.I.R. injection manifold welded in place. Add suffix "S" to the part number when ordering (Not available with ceramic finish headers).</p> <p>3 Must modify stock exhaust to retain catalytic converters.</p> <p>5 Can be modified to fit A.I.R. fittings in head.</p> <p>6 Applications with oxygen sensor use reducer #10105 for 2-1/2" 3-bolt flange or #10110 for 3" 3-bolt flange.</p> <p>8 Will not fit with A.I.R. injection pump.</p> <p>14 Will fit angle plug heads, factory Chevy aluminum only.</p> <p>15 Must modify rotary air conditioning bracket</p> <p>20 Power steering equipped use bracket #10041FLT for installation.</p> <p>22 It may be necessary to raise the automotive column cross shaft linkage by rotating the mounting brackets on frame and transmission 180 degrees.</p> <p>23 Installation requires FLOWTECH air conditioning bracket #10042. 1979 and later vehicles equipped with short compressor, use original bracket.</p> <p>24 Will not fit 440 6-pack 4-speed With 13" flywheel.</p> <p>42 May require clutch linkage modifications.</p> <p>51 Chevrolet small block V8 engine.</p> <p>53 Stock replacement, bolts directly to factory headpipes</p> <p>54 Shorty-style header, will also work on catalytic equipped vehicles. Head pipe fabrication required.</p> <p>58 Will not fit angle plug heads.</p> <p>61 Equal length "tuned" Shorty-style header bolts directly to factory H-pipes.</p> <p>66 Header is equipped with an oxygen sensor fitting.</p> | <p>67 Will not fit C6 Transmission</p> <p>70 Will fit with Dart/Windsor cylinder heads.</p> <p>71 Equal length "tuned" style header design</p> <p>80 Will not fit convertible models</p> <p>99 49 states emissions legal, California E.O. pending</p> <p>100 Will work with factory exhaust system</p> <p>101 Will not fit 400C</p> <p>102 Modification to stock exhaust required to retain stock catalytic converter</p> <p>103 On 1987 models, this header will only fit the 305 engine without the optional oil cooler</p> <p>104 Will fit Dart Sportsman II angle plug heads</p> <p>105 Fitting for exhaust gas temperature sensor is welded to header. If needed, hole must be drilled thru header tube</p> <p>106 Will not fit Cutlass "S" models</p> <p>236 Includes oxygen sensor extension harness(s)</p> <p>240 Will not fit vehicles with power steering</p> <p>250 Aluminumized "X" pipe that bolts to factory and aftermarket cat-back is available under p/n 12114YFLT</p> <p>251 Aluminumized "X" pipe that bolts to factory and aftermarket cat-back is available under p/n 12115YFLT</p> <p>252 "X" pipe is designed to work with header p/n 12114FLT only</p> <p>253 "X" pipe is designed to work with header p/n 12115FLT only</p> <p>** Short design</p> |
|---|--|





# FULL LENGTH HEADERS

## HEADERS

APPLICATION	YEAR	ENGINE	FLOWTECH I™ STANDARD	FLOWTECH II™ CERAMIC	PRI TUBE COL SIZE	AC	TRANSMISSION				FOOTNOTES	
							AUTO COL	FLR	STD COL	FLR		
<b>MERCURY</b>												
CAPRI	79-86	260-302W	12104FLT	32104FLT	1-1/2"x3"	Y	N	Y	N	Y	3,66,70,71	Ⓢ
COMET	66-69	260-302W	12100FLT	32100FLT	1-1/2"x3"	Y	Y	Y	N	Y	5,20,67	Ⓢ
COMET	71-73	351W	12100FLT	32100FLT	1-1/2"x3"	Y	N	Y	N	N	5,20,67	Ⓢ
COUGAR	67-70	260-302W	12102FLT	32102FLT	1-1/2"x3"	Y	N	Y	N	Y	5,20,67	Ⓢ
COUGAR	71-73	260-302W	12100FLT	32100FLT	1-1/2"x3"	Y	N	Y	N	N	5,20,67	Ⓢ
COUGAR	69-73	351W	12100FLT	32100FLT	1-1/2"x3"	Y	N	Y	N	N	5,20,67	Ⓢ
COUGAR	70-74	351C-4V	12118FLT	32118FLT	1-3/4"x3"	Y	Y	Y	N	N	20,67,101	Ⓢ
CYCLONE	68-73	260-302W	12100FLT	32100FLT	1-1/2"x3"	Y	Y	Y	N	Y	5,20,67	Ⓢ
CYCLONE	70-74	351C-4V	12118FLT	32118FLT	1-3/4"x3"	Y	Y	Y	N	N	20,67,101	Ⓢ
MONTEGO	68-73	260-302W	12100FLT	32100FLT	1-1/2"x3"	Y	Y	Y	N	Y	5,20,67	Ⓢ
MONTEGO	70-74	351C-4V	12118FLT	32118FLT	1-3/4"x3"	Y	Y	Y	N	N	20,67,101	Ⓢ
<b>OLDSMOBILE</b>												
442	78-87	260-403	11152FLT	31152FLT	1-3/4"x3"	Y	Y	Y	N	Y	3,6	Ⓢ
442	68-77	350-403	11150FLT	31150FLT	1-3/4"x3"	Y	Y	N	N	Y	3	Ⓢ
442	65-75	400-455	11154FLT	31154FLT	1-3/4"x3"	Y	Y	Y	N	Y	3	Ⓢ
CUTLASS	78-87	260-403	11152FLT	31152FLT	1-3/4"x3"	Y	Y	Y	N	Y	3,6	Ⓢ
CUTLASS	78-87	283-400ch	11102FLT	31102FLT	1-1/2"x2-1/2"	Y	Y	Y	N	Y	1,3,6,51,54,58	Ⓢ
CUTLASS	78-87	283-400ch	11104FLT	31104FLT	1-5/8"x3"	Y	Y	Y	N	N	3,6,23,51,58	Ⓢ
CUTLASS	78-87	283-400ch	11108FLT	31108FLT	1-5/8"x3"	23	Y	Y	N	N	3,14,15,54	Ⓢ
CUTLASS **	78-87	305ch	11114FLT	31114FLT	1-1/2"x2-1/2"	Y	Y	Y	N	Y	6,51,54,102,103,104,105	Ⓢ
CUTLASS	68-77	350-403	11150FLT	31150FLT	1-3/4"x3"	Y	Y	N	N	Y	3	Ⓢ
CUTLASS	65-75	400-455	11154FLT	31154FLT	1-3/4"x3"	Y	Y	Y	N	Y	3	Ⓢ
DELTA 88	71-75	400-455	11154FLT	31154FLT	1-3/4"x3"	Y	Y	Y	N	N	3	Ⓢ
VISTA CRUISER	78-87	260-403	11152FLT	31152FLT	1-3/4"x3"	Y	Y	Y	N	Y	3,6	Ⓢ
<b>PONTIAC</b>												
FIREBIRD	98-99	LS1	11133FLT	11133-1FLT	1-3/4"x3"	Y	N	Y	N	Y	66,234,236,248	Ⓢ
FIREBIRD	00-02	LS1	11134FLT	11134-1FLT	1-3/4"x3"	Y	N	Y	N	Y	66,234,236,248	Ⓢ
<b>Y-PIPE FOR 11133FLT &amp; 11134FLT</b>			11133YFLT	11133Y-1FLT							247	Ⓢ
FIREBIRD-TA	70-79	350-455	11170FLT	31170FLT	1-5/8"x3"	Y	N	Y	N	Y	3,27,37	Ⓢ
FIREBIRD-TA	77-81	350-403 olds	11150FLT	31150FLT	1-3/4"x3"	Y	Y	Y	N	Y	3	Ⓢ
FIREBIRD-TA **	82-89	305ch	11114FLT	31114FLT	1-1/2"x2-1/2"	Y	N	Y	N	Y	6,51,54,102,103,104,105	Ⓢ
FIREBIRD-TA**	82-92	305-350ch	11116FLT	31116FLT	1-1/2"x2-1/2"	Y	N	Y	N	Y	51,54,100,102,104	Ⓢ
FIREBIRD-TA	82-90	283-400ch	11102FLT	31102FLT	1-1/2"x2-1/2"	Y	N	Y	N	Y	1,3,6,51,54,58,66	Ⓢ
GRAND AM	64-75	326-455	11170FLT	31170FLT	1-5/8"x3"	Y	Y	Y	N	Y	3,27,37	Ⓢ
GRAND PRIX	78-87	283-400ch	11104FLT	31104FLT	1-5/8"x3"	23	Y	Y	N	N	3,6,51,58	Ⓢ
GTO	64-75	326-455	11170FLT	31170FLT	1-5/8"x3"	Y	Y	Y	N	Y	3,27,37	Ⓢ
LE MANS	64-75	326-455	11170FLT	31170FLT	1-5/8"x3"	Y	Y	Y	N	Y	3,27,37	Ⓢ
LE MANS	78-87	283-400ch	11104FLT	31104FLT	1-5/8"x3"	23	Y	Y	N	Y	3,6,51,58	Ⓢ

### INSTALLATION NOTES

Y = YES, N = NO, O = NOT VERIFIED

- |  |   |
|--|---|
| <p>1 Also available with A.I.R. injection manifold welded in place. Add suffix "S" to the part number when ordering (Not available with ceramic finish).</p> <p>3 Must modify stock exhaust to retain catalytic converters.</p> <p>5 Can be modified to fit A.I.R. fittings in head.</p> <p>6 Applications with oxygen sensor use reducer #10105 for 2-1/2" 3-bolt flange or #10110 for 3" 3-bolt flange.</p> <p>14 Will fit angle plug heads, factory Chevy aluminum only.</p> <p>15 Must modify rotary air conditioning bracket</p> <p>20 Power steering equipped use bracket #10041FLT for installation.</p> <p>23 Installation requires FLOWTECH air conditioning bracket #10042. 1979 and later vehicles equipped with short compressor, use original bracket.</p> <p>27 Will not fit Ram Air vehicles</p> <p>29 Will not fit 68-72 w/Camper Special gas tanks.</p> <p>37 End holes on head must be drilled and tapped to assure proper seal</p> <p>42 May require clutch linkage modifications.</p> <p>41 Chevrolet small block V8 engine.</p> <p>53 Stock replacement, bolts directly to factory headpipes</p> <p>54 Shorty-style header, will also work on catalytic equipped vehicles. Head pipe fabrication required.</p> <p>58 Will not fit angle plug heads.</p> <p>60 Installation requires front FLOWTECH frame mounts #22609. Powerglide and TH-350 trans. may use stock transmission crossmember. TH-400 use kit #22649.</p> <p>61 Equal length "tuned" Shorty-style header bolts directly to factory H-pipes.</p> <p>66 Header is equipped with an oxygen sensor fitting</p> <p>67 Will not fit C6 Transmission</p> <p>69 Must use original factory Big Block engine frame mounts and hardware.</p> | <p>70 Will fit with Dart/Windsor cylinder heads.</p> <p>71 Equal length "tuned" style header design</p> <p>75 Fits with OE factory equipped style transmission only.</p> <p>*90 Catalytic converter compatible Y-Pipe available separately, add suffix "Y" to part number.</p> <p>100 Will work with factory exhaust system</p> <p>101 Will not fit 400C</p> <p>102 Modification to stock exhaust required to retain stock catalytic converter</p> <p>103 On 1987 models, this header will only fit the 305 engine without the optional oil cooler</p> <p>104 Will fit Dart Sportsman II angle plug heads</p> <p>105 Fitting for exhaust gas temperature sensor is welded to header. If needed, hole must be drilled thru header tube</p> <p>106 Will not fit Cutlass "S" models</p> <p>234 Aluminized "Y" pipes that bolt to factory and aftermarket cat-backs is available under part# 11133YFLT</p> <p>236 Includes oxygen sensor extension harness(s)</p> <p>241 Will not fit C-6 trans.</p> <p>242 Will not fit with high torque starter.</p> <p>243 Collector is non flanged integral reducer type.</p> <p>244 Will not fit trucks with power take off.</p> <p>247 "Y" pipe is designed to bolt to either 11133FLT or 11134FLT</p> <p>248 Aluminized "Y" pipe that bolts to factory and aftermarket cat-back is available under p/n 11133Y-FLT</p> <p>** Short design</p> |
|--|---|

EO HEADERS

FULL LENGTH HEADERS

BLOCK HUGGER HEADERS

RACE HEADERS

IMPORT HEADERS

GLASS PACK MUFFLERS

TURBO-STYLE MUFFLERS

IMPORT MUFFLERS

CATBACKS

H-PIPES & X-PIPES

TIPS

COMPONENTS & ACCESSORIES

MERCHANDISING

PHOTO GALLERY PART # INDEX

# FULL LENGTH HEADERS

## HEADERS



APPLICATION	YEAR	ENGINE	FLOWTECH I™ STANDARD	FLOWTECH II™ CERAMIC	PRI TUBE COL SIZE	AC	TRANSMISSION				FOOTNOTES
							AUTO COL	FLR	STD COL	FLR	

### FLOWTECH TRUCK HEADERS

#### CHEVROLET/GMC - TWO WHEEL DRIVE

*1500,2500,3500	88-95	5.0-5.7L	11504FLT	31504FLT	1-5/8"x3"	Y	Y	N	N	Y	3,6,58,75,90	Ⓢ
1 TON CREW	88-91	283-400	11500FLT	31500FLT	1-1/2"x3"	23	Y	N	N	Y	1,3,6,42,58	Ⓢ
1/2, 3/4 TON	66-72	283-400	11500FLT	31500FLT	1-1/2"x3"	23	Y	N	Y	Y	1,32,42,58	Ⓢ
1/2, 3/4, 1 TON	73-87	283-400	11500FLT	31500FLT	1-1/2"x3"	23	Y	N	N	Y	1,3,42,58	Ⓢ
1/2, 3/4, 1 TON	68-87	396-454	11530FLT	31530FLT	1-3/4"x3"	Y	Y	Y	N	N	3,6,69	Ⓢ
1/2,3/4, 1 TON PU	88-91	305-350	11508FLT	31508FLT	1-1/2"x2-1/2"	Y	Y	Y	Y	Y	58,102,104	Ⓢ
BLAZER/JIMMY	68-87	396-454	11530FLT	31530FLT	1-3/4"x3"	Y	Y	Y	N	N	1,3,6,69	Ⓢ
BLAZER/JIMMY	67-87	283-400	11500FLT	31500FLT	1-1/2"x3"	23	Y	N	N	Y	1,3,6,42,58	Ⓢ
SUBURBAN	73-91	283-400	11500FLT	31500FLT	1-1/2"x3"	23	Y	N	N	Y	1,3,6,42,58	Ⓢ
SUBURBAN	73-91	396-454	11530FLT	31530FLT	1-3/4"x3"	Y	Y	Y	N	N	3,6,69	Ⓢ
S10/15 PU Eng Swap	82-93	283-400	11502FLT	31502FLT	1-1/2"x2-1/2"	0	Y	Y	0	0	3,6,54,58,60	Ⓢ
S10 BLAZER Swap	82-93	283-400	11502FLT	31502FLT	1-1/2"x2-1/2"	0	Y	Y	0	0	3,6,54,58,60	Ⓢ
S10/15 PU, Blazer Frame Mount Kit	82-93	283-400	22609FLT									

#### DODGE/PLYMOUTH - TWO WHEEL DRIVE

1/2, 3/4 TON PU	72-93	273-360	13500FLT	33500FLT	1-5/8"x3"	Y	Y	N	Y	Y	3,6,8,242,243	Ⓢ
-----------------	-------	---------	----------	----------	-----------	---	---	---	---	---	---------------	---

#### FORD - TWO WHEEL DRIVE

F100	69-79	302W	12500FLT	32500FLT	1-1/2"x3"	Y	Y	N	Y	Y	3,5	Ⓢ
F100/150/250	80-95	302W	12502FLT	32502FLT	1-1/2"x2-1/2"	Y	Y	N	N	N	3,6	Ⓢ
F100/150/250/350	80-86	351-400M	12522FLT	32522FLT	1-1/2"x2-1/2"	Y	Y	N	N	N	3,6,244	Ⓢ
1/2,3/4 TON PU	77 1/2-79	351-400M	12506FLT	32506FLT	1-3/4"x3"	Y	Y	N	Y	Y	102	Ⓢ
F100/150/250	65-76	352-428	12540FLT	32540FLT	1-3/4"x3"	Y	Y	N	Y	Y	3,29	Ⓢ
F250/350	74-79	429 - 460	12564FLT	32564FLT	1-3/4"x2-1/2"	Y	Y	N	N	N	3,243	Ⓢ
F100/150/250	80-87	429 - 460	12560FLT	32560FLT	1-3/4"x3"	Y	Y	Y	Y	Y	3,6	Ⓢ

#### CHEVROLET/GMC - FOUR WHEEL DRIVE

*1500,2500,3500 PU	88-95	5.0-5.7L	11504FLT	31504FLT	1-5/8"x3"	Y	Y	Y	N	Y	3,6,58,75,90	Ⓢ
1 TON CREW CAB	88-91	283-400	11500FLT	31500FLT	1-1/2"x3"	23	Y	N	0	Y	1,3,6,21,50,58,42	Ⓢ
1/2, 3/4 TON PU	68-81	396-454	11530FLT	31530FLT	1-3/4"x3"	Y	Y	Y	N	N	3,6,69	Ⓢ
1/2, 3/4, 1 TON PU	73-87	283-400	11500FLT	31500FLT	1-1/2"x3"	23	Y	N	N	Y	1,3,6,21,58,42	Ⓢ
1/2,3/4, 1 TON PU	88-91	305-350	11508FLT	31508FLT	1-1/2"x2-1/2"	Y	Y	Y	Y	Y	58,102,104	Ⓢ
1/2, 3/4 TON PU	66-72	2 83-400	11500FLT	31500FLT	1-1/2"x3"	23	Y	N	42	42	1,32,58,42	Ⓢ
1/2, 3/4, 1 TON PU	67-87	283-400	11506FLT	31506FLT	1-5/8"x2-1/2"	23	Y	N	N	Y	3,6,21,58	Ⓢ
1/2,3/4, 1 TON PU	63-87	292	11510FLT	31510FLT	1-1/2"x2-1/2"	Y	Y	Y	N	Y	102	Ⓢ
1/2,3/4, 1 TON PU	63-74	230-250	11510FLT	31510FLT	1-1/2"x2-1/2"	Y	Y	Y	N	Y	102	Ⓢ
BLAZER/JIMMY K5	73-91	283-400	11500FLT	31500FLT	1-1/2"x3"	23	Y	N	N	Y	1,3,6,21,58	Ⓢ
BLAZER/JIMMY K5	69-72	283-400	11500FLT	31500FLT	1-1/2"x3"	23	Y	N	42	42	1,32,58	Ⓢ
BLAZER/JIMMY K5	73-81	396-454	11530FLT	31530FLT	1-3/4"x3"	Y	Y	Y	N	N	3,6,69	Ⓢ
BLAZER/JIMMY K5	67-91	283-400	11506FLT	31506FLT	1-5/8"x2-1/2"	23	Y	N	N	Y	3,6,21,58,42	Ⓢ
SUBURBAN	73-91	283-400	11500FLT	31500FLT	1-1/2"x3"	23	Y	N	N	Y	1,3,6,21,58,42	Ⓢ
SUBURBAN	66-72	283-400	11500FLT	31500FLT	1-1/2"x3"	23	Y	N	42	42	1,3,32,58	Ⓢ
SUBURBAN	73-81	396-454	11530FLT	31530FLT	1-3/4"x3"	Y	Y	Y	Y	Y	3,6,69	Ⓢ
SUBURBAN	67-91	283-400	11506FLT	31506FLT	1-5/8"x2-1/2"	23	Y	N	N	Y	3,6,21,58	Ⓢ

### INSTALLATION NOTES

Y = YES, N = NO, 0 = NOT VERIFIED

1	Also available with A.I.R. injection manifold welded in place. Add suffix "S" to the part number when ordering (Not available with ceramic finish).	54	Shorty-style header, will also work on catalytic equipped vehicles. Head pipe fabrication required.
3	Must modify stock exhaust to retain catalytic converters.	58	Will not fit angle plug heads.
5	Can be modified to fit A.I.R. fittings in head.	60	Installation requires front FLOWTECH frame mounts #22609. Powerglide and TH-350 trans. may use stock transmission crossmember. TH-400 use kit #22649.
6	Applications with oxygen sensor use reducer #10105 for 2-1/2" 3-bolt flange or #10110 for 3" 3-bolt flange.	66	Header is equipped with an oxygen sensor fitting
21	On 83-84 4WD, it is necessary to remove the rubber stopper below the starter.	69	Must use original factory Big Block engine frame mounts and hardware.
23	Installation requires FLOWTECH air conditioning bracket #10042. 1979 and later vehicles equipped with short compressor, use original bracket.	75	Fits with OE factory equipped style transmission only.
27	Will not fit Ram Air vehicles	*90	Catalytic converter compatible Y-Pipe available separately, add suffix "Y" to part number.
28	Will fit only "LOW BOY" F-250's that were manufactured after 2/1/77. The date of manufacture is located on the driver side door frame.	100	Will work with factory exhaust system
29	Will not fit 68-72 w/Camper Special gas tanks.	102	Modification to stock exhaust required to retain stock catalytic converter
32	Pre-70 vehicles with exhaust manifold mounted Alternator/Generator use bracket #10031FLT.	103	On 1987 models, this header will only fit the 305 engine without the optional oil cooler
37	End holes on head must be drilled and tapped to assure proper seal	104	Will fit Dart Sportsman II angle plug heads
42	May require clutch linkage modifications.	105	Fitting for exhaust gas temperature sensor is welded to header. If needed, hole must be drilled thru header tube
50	Fits C30 Crew Cab type chassis only.	241	Will not fit C-6 trans.
51	Chevrolet small block V8 engine.	242	Will not fit with high torque starter.
		243	Collector is non flanged integral reducer type.
		244	Will not fit trucks with power take off.
		**	Short design

APPLICATION	YEAR	ENGINE	FLOWTECH I™ STANDARD	FLOWTECH II™ CERAMIC	PRI TUBE COL SIZE	AC	TRANSMISSION				FOOTNOTES	
							AUTO COL	FLR	STD COL	FLR		
<b>DODGE/PLYMOUTH/JEEP - FOUR WHEEL DRIVE</b>												
1/2, 3/4 TON PU	72-93	273-360	13500FLT	33500FLT	1-5/8"x3"	Y	Y	N	N	Y	6,8,102,242,244	3
1/2, 3/4 TON PU	67-82	383-440	13504FLT	33504FLT	1-3/4"x3"	Y	Y	N	N	Y	102,242,244	3
CJ 5/6/7FENDER	72-82	290-401	13550FLT	33550FLT	1-5/8"x3"	Y	Y	N	Y	Y	3,57	3
CJ 5/6/7	72-79	290-401	13502FLT	33502FLT	1-5/8"x3"	Y	Y	N	N	Y	102	3
RAMCHARGER	74-93	273-360	13500FLT	33500FLT	1-5/8"x3"	Y	Y	N	N	Y	3,6,8	3
TRAILDUSTER	74-78	383-440	13504FLT	33504FLT	1-3/4"x3"	Y	Y	N	N	Y	102,242,244	3
TRAILDUSTER	74-93	273-360	13500FLT	33500FLT	1-5/8"x3"	Y	Y	N	N	Y	3,6,8	3
<b>FORD - FOUR WHEEL DRIVE</b>												
F100/150	65-76	332-428	12542FLT	32542FLT	1-3/4"x3"	Y	Y	N	Y	Y	3	3
F250	67-76	332-428	12542FLT	32542FLT	1-3/4"x3"	Y	Y	N	Y	Y	3	3
F100/150/250/350	80-95	302W	12502FLT	32502FLT	1-1/2"x2-1/2"	Y	Y	N	N	N	3	3
F100/150/250/350	80-88	351W	12504FLT	32504FLT	1-1/2"x2-1/2"	N	Y	Y	N	N	3	3
F150/250/350	77-79	351-400M	12520FLT	32520FLT	1-5/8"x3"	Y	Y	N	Y	Y	3,28	3
1/2,3/4, 1 TON PU	78-79	351-400M	12508FLT	32508FLT	1-3/4"x3"	Y	Y	N	Y	Y	54,102	3
F250/350	83-87	460	12560FLT	32560FLT	1-3/4"x3"	Y	Y	Y	Y	Y	3,6	3
BRONCO	80-95	302W	12502FLT	32502FLT	1-1/2"x2-1/2"	Y	Y	N	N	N	3	3
BRONCO	80-95	351W	12504FLT	32504FLT	1-1/2"x2-1/2"	O	Y	Y	O	O	3	3
BRONCO	78-79	351-400M	12508FLT	32508FLT	1-3/4"x3"	Y	Y	N	Y	Y	54,102	3
BRONCO	78-79	351-400M	12520FLT	32520FLT	1-5/8"x3"	Y	Y	N	Y	Y	3	3

### INSTALLATION NOTES

Y = YES, N = NO, O = NOT VERIFIED

- |   |   |
|---|---|
| <ul style="list-style-type: none"> <li>1 Also available with A.I.R. injection manifold welded in place. Add suffix "S" to the part number when ordering (Not available with ceramic finish).</li> <li>3 Must modify stock exhaust to retain catalytic converters.</li> <li>6 Applications with oxygen sensor use reducer #10105 for 2-1/2" 3-bolt flange or #10110 for 3" 3-bolt flange.</li> <li>21 On 83-84 4WD, it is necessary to remove the rubber stopper below the starter.</li> <li>23 Installation requires FLOWTECH air conditioning bracket #10042. 1979 and later vehicles equipped with short compressor, use original bracket.</li> <li>28 Will fit only "LOW BOY" F-250's that were manufactured after 2/1/77. The date of manufacture is located on the driver side door frame.</li> <li>32 Pre-70 vehicles with exhaust manifold mounted Alternator/Generator use bracket #10031FLT.</li> <li>42 May require clutch linkage modifications.</li> <li>50 Fits C30 Crew Cab type chassis only.</li> </ul> | <ul style="list-style-type: none"> <li>54 Shorty-style header, will also work on catalytic equipped vehicles. Head pipe fabrication required.</li> <li>57 Will not fit tire above 36 in.</li> <li>58 Will not fit angle plug heads.</li> <li>69 Must use original factory Big Block engine frame mounts and hardware.</li> <li>75 Fits with OE factory equipped style transmission only.</li> <li>*90 Catalytic converter compatible Y-Pipe available separately, add suffix "Y" to part number.</li> <li>102 Modification to stock exhaust required to retain stock catalytic converter</li> <li>104 Will fit Dart Sportsman II angle plug heads</li> <li>242 Will not fit with high torque starter.</li> <li>243 Collector is non flanged integral reducer type.</li> <li>244 Will not fit trucks with power take off.</li> </ul> |
|---|---|

## Y-Pipes

FLOWTECH's Y-Pipes are ideal for connecting standard FLOWTECH headers to your stock catalytic converter-equipped exhaust system.

Y-PIPE P/N	USE W/ FLOWTECH P/N	APPLICATION	YEAR	ENGINE	
11102YFLT	11102	CAMARO & FIREBIRD	86-92	305-350	3
11133YFLT	11133FLT & 11134FLT	CAMARO & FIREBIRD	98-02	LS1	3
11133Y-1FLT	11133-1FLT & 11134-1FLT	CAMARO & FIREBIRD, Ceramic	98-02	LS1	3
11504YFLT	11504	CHEVY PU 2/4 WD	88-95	305-350	3
49154YFLT	49154	CHEVY PU 2 WD	88-95	305-350	3
49156YFLT	49156	CHEVY PU 4 WD	88-95	305-350	3



# AFTERBURNER™ HEADERS



## AFTERBURNER™ TURBO CHAMBER HEADERS™ Break New Ground!

FLOWTECH Afterburner headers provide an optimal balance between horsepower output and maximum torque. The stainless steel Turbo Chamber secondary collectors scavenges exhaust gases from the out-of-sequence cylinder at the same flow rate as the other 3 cylinders on the same bank. The Turbo Chamber combines with small primary tubes to produce low RPM torque without sacrificing mid and upper-RPM horsepower. The result is a broad power band and strong torque multiplication whenever you need it. With Afterburner you are always good to go!

- Innovative design for small block Chevy equipped vehicles
- Increases both horsepower and torque
- Large 3" secondary collector
- Patented Turbo Chamber design to increase scavenging and smooth exhaust pulses
- Premium high temperature electrostatic gray finish

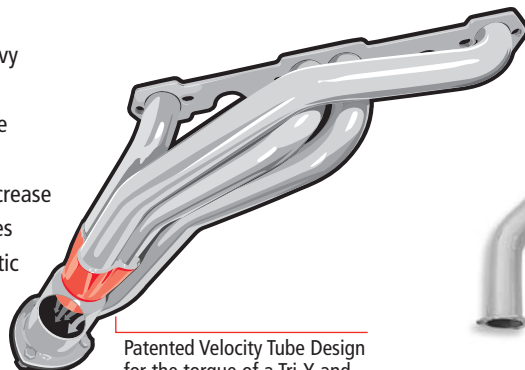

Patented Velocity Tube Design for the torque of a Tri-Y and the horsepower of big tubes



APPLICATION	YEAR	ENGINE	FLOWTECH I™ STANDARD	FLOWTECH II™ CERAMIC	PRI TUBE COL SIZE	AC	TRANSMISSION				FOOTNOTES	
							AUTO COL	FLR	STD COL	FLR		
<b>AFTERBURNER HEADER APPLICATIONS</b>												
<b>BUICK w/CHEVY ENGINE</b>												
REGAL	78-87	283-400	49100FLT	49100-1FLT	1-5/8"x3"	23	Y	Y	N	N	4,6,51,58	3
<b>CHEVROLET</b>												
CAMARO	67-81	283-400	49100FLT	49100-1FLT	1-5/8"x3"	23	Y	Y	N	N	3,4,12,15,58	3
CHEVELLE	68-87	283-400	49100FLT	49100-1FLT	1-5/8"x3"	23	Y	Y	N	N	3,4,15,58	3
CHEVY II/NOVA	68-79	283-400	49100FLT	49100-1FLT	1-5/8"x3"	N	Y	Y	N	N	3,4,58	3
MONTE CARLO	70-88	283-400	49100FLT	49100-1FLT	1-5/8"x3"	23	Y	Y	N	N	3,4,15,58	3
<b>OLDSMOBILE w/CHEVY ENGINE</b>												
CUTLASS	78-87	283-400	49100FLT	49100-1FLT	1-5/8"x3"	23	Y	Y	N	N	3,4,15,51,58	3
<b>PONTIAC w/CHEVY ENGINE</b>												
GRAND PRIX	78-87	283-400	49100FLT	49100-1FLT	1-5/8"x3"	23	Y	Y	N	N	3,4,6,51,58	3
<b>CHEVROLET/GMC - TWO WHEEL DRIVE</b>												
* 1500,2500,3500	88-95	5.0/5.7L	49154FLT	49154-1FLT	1-5/8"x3"	Y	Y	Y	N	N	3,4,6,58,75,90	3
1 TON CREW CAB	88-91	283-400	49150FLT	49150-1FLT	1-5/8"x3"	23	Y	N	N	N	3,4,6,50,58	3
1/2,3/4,1 TON PU	73-87	283-400	49150FLT	49150-1FLT	1-5/8"x3"	23	Y	N	N	N	3,4,58	3
BLAZER/JIMMY	73-91	283-400	49150FLT	49150-1FLT	1-5/8"x3"	23	Y	N	N	N	3,4,6,58	3
SUBURBAN	73-91	283-400	49150FLT	49150-1FLT	1-5/8"x3"	23	Y	N	N	N	3,4,6,58	3
<b>CHEVROLET/GMC - FOUR WHEEL DRIVE</b>												
* 1500,2500,3500	88-95	5.0/5.7L	49156FLT	49156-1FLT	1-5/8"x3"	Y	Y	Y	N	N	3,4,6,58,75,90	3
1 TON CREW CAB	88-91	283-400	49152FLT	49152-1FLT	1-5/8"x3"	23	Y	N	N	N	3,4,6,21,50,58	3
1/2,3/4,1 TON PU	73-87	283-400	49152FLT	49152-1FLT	1-5/8"x3"	23	Y	N	N	N	3,4,6,21,58	3
BLAZER/JIMMY	73-91	283-400	49152FLT	49152-1FLT	1-5/8"x3"	23	Y	N	N	N	3,4,6,21,58	3
SUBURBAN	73-91	265-400	49152FLT	49152-1FLT	1-5/8"x3"	23	Y	N	N	N	3,4,6,21,58	3

### INSTALLATION NOTES

Y = YES, N = NO, O = NOT VERIFIED

- Must modify stock exhaust to retain catalytic converters.
- Not legal for use on pollution controlled motor vehicles. Legal only for racing vehicles that will never be driven upon a highway. If you have any questions please contact your FLOWTECH dealer.
- Applications with oxygen sensor use reducer #10105 for 2-1/2" 3-bolt flange or #10110 for 3" 3-bolt flange.
- Will not fit 67-69 Camaro with air conditioning.
- Must modify rotary air conditioning bracket.
- On 83-84 4-WD it is necessary to remove the rubber stopper below the starter.
- Installation requires FLOWTECH air conditioning bracket #10042. 1979 and later vehicles equipped with short compressor, use original bracket.

- Fits C30 Crew Cab type chassis only.
- Chevrolet small block V-8 engine.
- Will not fit angle plug heads.
- Fits with OE factory equipped style transmission only.
- Catalytic converter compatible Y-Pipe available separately. Add suffix "Y" to part number. (see page 10)

### Precision Engineered for Maximum Performance

FLOWTECH headers are specifically designed and built for Ford 5.0L Mustangs, the world's most popular pony car. Available in either equal or unequal length configurations, (with your choice of standard, high-temperature electrostatic black paint finish or long-lasting NASA luster silver ceramic finish.)

- Precision formed steel flanges
- Tuned tubing lengths
- Threaded H-Pipe mounting holes
- Fits all '86-'96 5.0L Mustangs

### Equal Length EO Headers

A true equal-length design, the FLOWTECH Mustang header is an excellent choice for the Mustang owner who wants to get the most from their 5.0L (302 c.i.d.) V-8 and still accommodates all emission control components. Large 1 5/8" mandrel-bent tubing with your choice of finishes.



### Unequal Length Headers

The FLOWTECH unequal length header is your best choice for stock or mildly-modified street applications where ease of installation is paramount. The mandrel-bent tubes unlock wasted horsepower by increasing flow while reducing backpressure. Also available in your choice of finishes.



### Equal Length Long Tube Headers

FLOWTECH equal length long tube headers are designed for 5.0L Mustang and Capri owners who demand maximum power and performance. These true equal length headers are built from select lengths of mandrel-bent 1 5/8" tubing, including FLOWTECH's exclusive Power Plenum™ collector. This header is also equipped with an oxygen sensor fitting that accepts the stock sensors. (Available in your choice of finishes.)



APPLICATION	YEAR	ENGINE	FLOWTECH I™ STANDARD	FLOWTECH II™ CERAMIC	PRI TUBE COL SIZE	AC	TRANSMISSION				FOOTNOTES	
							AUTO		STD			
							COL	FLR	COL	FLR		
<b>MUSTANG GT/LX 5.0L HEADERS</b>												
<b>EO HEADERS</b>												
Unequal Length	86-93	5.0L	12106FLT	N/A	1-1/2"xOE	Y	N	Y	N	Y	53	3
Unequal Length	86-93	5.0L	12107FLT	32107FLT	1-5/8"xOE	Y	N	Y	N	Y	53	3
Unequal Length	94-95	5.0L	12112FLT	32112FLT	1-5/8"xOE	Y	N	Y	N	Y	53	3
Equal Length	86-93	5.0L	12110FLT	32110FLT	1-5/8"x17"xOE	Y	N	Y	N	Y	61,70,71	3
<b>FULL LENGTH HEADERS</b>												
Equal Length	79-93	5.0L	12104FLT	32104FLT	1-5/8"x30"x3"	Y	N	Y	N	Y	3,66,70,71	3
Equal Length 4V	96-02	4.6L	12114FLT	12114-1FLT	1-5/8"x3"	Y	N	Y	N	Y	236,250	3
Cross Pipe for 12114FLT			12114YFLT	N/A							252	3
Equal Length 2V	96-03	4.6L	12115FLT	12115-1FLT	1-5/8"x3"	Y	N	Y	N	Y	236,251	3
Cross Pipe for 12115FLT			12115YFLT	N/A							253	3

### INSTALLATION NOTES

Y = YES, N = NO, O = NOT VERIFIED

- |   |   |
|---|---|
| <p>3 Must modify stock exhaust to retain catalytic converters.</p> <p>53 Stock replacement, bolts directly to factory headpipes.</p> <p>61 Equal length "tuned" Shorty-style header. Bolts directly to Factory H-Pipes.</p> <p>66 Header is equipped with an oxygen sensor fitting.</p> <p>70 Will fit with Dart/Windsor cylinder heads.</p> <p>71 Equal length "tuned" style header design.</p> <p>236 Includes oxygen sensor extension harness(s)</p> | <p>250 Aluminized "X" pipe that bolts to factory and aftermarket cat-back is available under p/n 12114FLT</p> <p>251 Aluminized "X" pipe that bolts to factory and aftermarket cat-back is available under p/n 12115FLT</p> <p>252 "X" pipe is designed to work with header p/n 12114FLT only</p> <p>253 "X" pipe is designed to work with header p/n 12115FLT only</p> |
|---|---|

- EO HEADERS
- FULL LENGTH HEADERS**
- BLOCK HUGGER HEADERS
- RACE HEADERS
- IMPORT HEADERS
- GLASS PACK MUFFLERS
- TURBO-STYLE MUFFLERS
- IMPORT MUFFLERS
- CATBACKS
- H-PIPES & X-PIPES
- TIPS
- COMPONENTS & ACCESSORIES
- MERCHANDISING
- PHOTO GALLERY
- PART # INDEX

## Precision Engineered for Maximum Engine Performance!

FLOWTECH's Camaro and Firebird headers with Y-Pipes are precision engineered to get maximum performance and fuel economy from your engine. Each header is formed from specially selected .060 cold roll flash controlled tubing, and features FLOWTECH's exclusive thick mandrel-formed Power Plenum™ collector. All ports are precisely fitted and finished with sturdy, leak-proof O-ringed port seals, and all FLOWTECH headers come with all mounting hardware, including bolts, nuts and premium gaskets.

FLOWTECH's headers are available with either a high-quality, electrostatically-applied PPG satin black paint finish or with a specially formulated, show-ceramic coating for longer rust and corrosion resistance.

- Mandrell-formed Power Plenum™ collectors for low backpressure
- Constructed of thick cold roll flash controlled tubing for durability
- Precision-engineered for fit, performance and economy
- Includes all mounting hardware and gaskets



APPLICATION	YEAR	ENGINE	STANDARD FINISH	SHOW CERAMIC	PRI TUBE COL SIZE	AC	TRANSMISSION				FOOTNOTES	
							AUTO		STD			
							COL	FLR	COL	FLR		
CAMARO/FIREBIRD, SINGLE CAT	86-92	305-350	16102FLT*	16102-1FLT*	1-1/2"x2-1/2"	Y	N	Y	N	Y	99,100	2
CAMARO	67-81	283-400	11108FLT	31108FLT	1-1/2"x2-1/2"	23	Y	Y	N	N	3,12,14,15,54	3
CAMARO	70-81	283-400	11100FLT	31100FLT	1-5/8"x3"	23	Y	Y	N	Y	3,6,31,58	3
CAMARO	82-91	283-400	11102FLT	31102FLT	1-1/2"x2-1/2"	Y	N	Y	N	Y	3,54,58,66,90,249	3
CAMARO.	67-69	396-454	11132FLT	31132FLT	1-7/8"x3-1/2"	Y	Y	Y	N	Y		3
CAMARO	70-72	396-454	11130FLT	31130FLT	1-3/4"x3"	Y	N	Y	N	Y		3
CAMARO Z/28**	82-89	305	11114FLT	31114FLT	1-1/2"x2-1/2"	Y	N	Y	N	Y	54,103,104,105	3
CAMARO Z/28**	82-92	305-350	11116FLT	31116FLT	1-1/2"x2-1/2"	Y	N	Y	N	Y	54,104,66	3
CAMARO/FIREBIRD	98-99	LS1	11133FLT	11133-1FLT	1-3/4"x3"	Y	N	Y	N	Y	66,234,236,248	3
CAMARO/FIREBIRD	00-02	LS1	11134FLT	11134-1FLT	1-3/4"x3"	Y	N	Y	N	Y	66,234,236,248	3
Y-PIPE FOR 11133FLT & 11134FLT			11133YFLT	11133Y-1FLT							247	3

### INSTALLATION NOTES

= YES, N = NO, O = NOT VERIFIED

- 3 Must modify stock exhaust to retain catalytic converters.  
 6 Applications with oxygen sensor use reducer #10105 for 2-1/2" 3-bolt flange or #10110 for 3" 3-bolt flange.  
 12 Will not fit 67-69 Camaro with air conditioning.  
 14 Will fit angle plug heads, factory Chevy aluminum only.  
 15 Must modify rotary air conditioning bracket.  
 31 Must modify lower A-Arm support bracket on 79-81 models.  
 54 Shorty-style header, will also work on catalytic equipped vehicles. Head pipe fabrication required.  
 58 Will not fit angle plug heads.  
 66 Header is equipped with an oxygen sensor fitting  
 \*90 Catalytic converter compatible Y-Pipe available separately, add suffix "Y" to part number.  
 99 49 states emissions legal, California E.O. pending  
 100 Will work with factory exhaust system.

- 103 On 1987 models, this header will only fit  
 104 Will fit Dart Sportsman II angle plug heads  
 105 Fitting for exhaust gas temperature sensor is welded to header. If needed, hole must be drilled thru header tube  
 234 Aluminized "Y" pipes that bolt to factory and aftermarket cat-backs is available under part# 11133YFLT  
 236 Includes oxygen sensor extension harness(s)  
 247 "Y" pipe is designed to bolt to either 11133FLT or 11134FLT  
 248 Aluminized "Y" pipe that bolts to factory and aftermarket cat-back is available under p/n 11133Y-FLT  
 249 With A.I.R.  
 \* Y-Pipe included

## BLOCK HUGGER HEADERS PERFORMANCE WITH STYLE!

FLOWTECH Block Hugger headers are ideal for street rods where the fit is tight. Block Huggers make performance and style easy for engine swaps, and with our new Hugger Toobs you can hook up to an existing exhaust system with ease.

- Precision die-cut exhaust port flanges
- Computer-controlled mandrel-bent tubing
- Engineered and tested for leak-proof seal
- Headers include all nuts, bolts and gasket
- Standard Finish Block Huggers feature an electrostatically applied PPG satin black paint finish
- Metallic Ceramic Finish Block Huggers feature a high luster silver finish for great looks and provides superior rust and corrosion resistance



APPLICATION	ENGINE	FLOWTECH I™ STANDARD	FLOWTECH II™ CERAMIC	PRI TUBE COL SIZE
<b>HUGGER TOOBS</b>				
UNIVERSAL STREET ROD	265-400	10010FLT	-	2 1/2"



32000FLT

APPLICATION	ENGINE	FLOWTECH I™ STANDARD	FLOWTECH II™ CERAMIC	PRI TUBE COL SIZE
<b>CHEVROLET</b>				
UNIVERSAL STREET ROD	265-400	11000FLT	31000FLT	1-5/8" x 2-1/2"
UNIVERSAL STREET ROD	396-454	11030FLT	31030FLT	1-3/4" x 2-1/2"
<b>FORD</b>				
UNIVERSAL STREET ROD	289-351W	12000FLT	32000FLT	1-5/8" x 2-1/2"

## COMPLETE THE SYSTEM WITH HUGGER TOOBS!

Our Hugger Toobs Part Number 10010FLT offers a universal installation solution for all small block Chevy V-8 applications (Headers sold separately).

- Designed to connect Block Huggers to existing exhaust systems
- Built from thick, heavy-duty 16-gauge mandrel-bent tubing
- Kits sold in pairs, complete with flanges and premium gaskets
- Universal Block Header installation kit for small block 265-400 Chevy V-8

EO HEADERS

FULL LENGTH HEADERS

BLOCK HUGGER HEADERS

RACE HEADERS

IMPORT HEADERS

GLASS BACK MUFFLERS

TURBO-STYLE MUFFLERS

IMPORT MUFFLERS

CATBACKS

H-PIPES & X-PIPES

TIPS

COMPONENTS & ACCESSORIES

MERCHANDISING

PHOTO GALLERY PART # INDEX

# IMCA STYLE RACE CAR HEADERS

## HEADERS



We've designed our FLOWTECH Racing Headers for top engine performance on street, strip or circle track. They feature thick, heavy-duty  $5/16"$  port flanges and equal length 16-gauge primary tubes, an electrostatically applied PPG™ satin black paint finish, and complete mounting kit including premium gaskets and hardware.

- Equal length, large diameter 16-gauge primary tubes
- Designed for maximum performance for all applications
- High-flow Power Plenum collectors for low backpressure
- Strong, thick  $5/16"$  port flanges
- Includes all mounting hardware and premium gaskets



### IMCA STYLE RACE HEADERS

APPLICATIONS	P/N	CHASSIS	PRI TUBE	COL SIZE
<b>CHEVROLET</b>				
SMALL BLOCK CHEVY	48100FLT	Most	1 5/8"	3-1/2"
SMALL BLOCK CHEVY (Adjustable)	48102FLT	Most	1-5/8" x 1-3/4"	3"
<b>FORD</b>				
FORD 289-351W	48200FLT	Most	1-5/8"	3"





Airmass® Street Emissions-Legal Headers are designed and built to get maximum horsepower from your 4-cylinder sport compact. An Airmass header will give you more performance and torque on the dragstrip, road course, or just for cruising down the boulevard — and it looks awesome!

Available in COMPBLU™ or SHOCROM™ CERAMIC finishes for performance, durability, corrosion resistance and appearance

- Triple-thick premium ceramic metallic exterior coating
- Internal ceramic finish to increase exhaust flow through header increasing horsepower
- 50 state legal C.A.R.B. EO. D-115-14
- 4-2-1 collector design for maximum torque and horsepower
- CNC billet flanges throughout for a perfect seal with out warping
- Thick-wall mandrel-bent 16-ga. tubing retains heat for more power
- 100% heli-arc welded seams that look great and won't leak

## AIRMASS PRO-RACING HEADERS

MAKE	MODEL	YEAR	COMPBLU™	SHOCROM™	Painted	
ACURA	INTEGRA GSR	90-93			80102FLT	◆
ACURA	INTEGRA NON GSR	94-98	80004FLT	80504FLT		◆
ACURA	INTEGRA GSR	94-98	80006FLT	80506FLT		◆
HONDA	ACCORD SOHC VTEC	98-00	80034FLT	80534FLT		◆
HONDA	ACCORD ALL	94-95	80026FLT			◆
HONDA	ACCORD VTEC ONLY	96-97	80032FLT			◆
HONDA	CIVIC CRX	88-91		80522FLT		◆
HONDA	CIVIC ALL	92-95	80024FLT	80524FLT		◆
HONDA	CIVIC EX	96-98		80528FLT		◆
HONDA	CIVIC SI	99-00	80040FLT	80540FLT		◆
HONDA	DEL SOL DOHC VTEC	94-97	80040FLT	80540FLT		◆
HONDA	DEL SOL	94-97	80024FLT	80524FLT	80124FLT	◆

- EO HEADERS
- FULL LENGTH HEADERS
- BLOCK HUGGER HEADERS
- RACE HEADERS
- IMPORT HEADERS
- GLASS PACK MUFFLERS
- TURBO-STYLE MUFFLERS
- IMPORT MUFFLERS
- CATBACKS
- H-PIPES & X-PIPES
- TIPS
- COMPONENTS & ACCESSORIES
- MERCHANDISING
- PHOTO GALLERY PART # INDEX

# AIRMASS® PRO-STEP™ HEADERS



## Produce maximum horsepower at high RPM without losing torque at lower RPM!

**Sequentially fired collectors** - Firing primary tubes in sequence or rotation improves exhaust velocity and pressure wave tuning.

**Stepped header pipes** - A step, or sudden increase in cross-sectional area in the primary pipe will reduce the force necessary to accelerate the gas already in the pipe and reduce the pressure build-up. There is a pressure wave reflected from both the step and the end of the larger diameter secondary pipe. The returning waves of different amplitude are combined to produce a lower pressure drop at the exhaust port for a prolonged period.

- Durable 16-gauge tubing
- 1 1/2" - 1 5/8" stepped header pipes
- Machined sealing rings for leak free seal
- Unique long transition for increased exhaust velocity & maximum ground clearance
- 50-state legal (E.O. D-115-13)
- Triple-thick premium exterior coating
- Internal ceramic finish to increase exhaust flow through header increasing horsepower

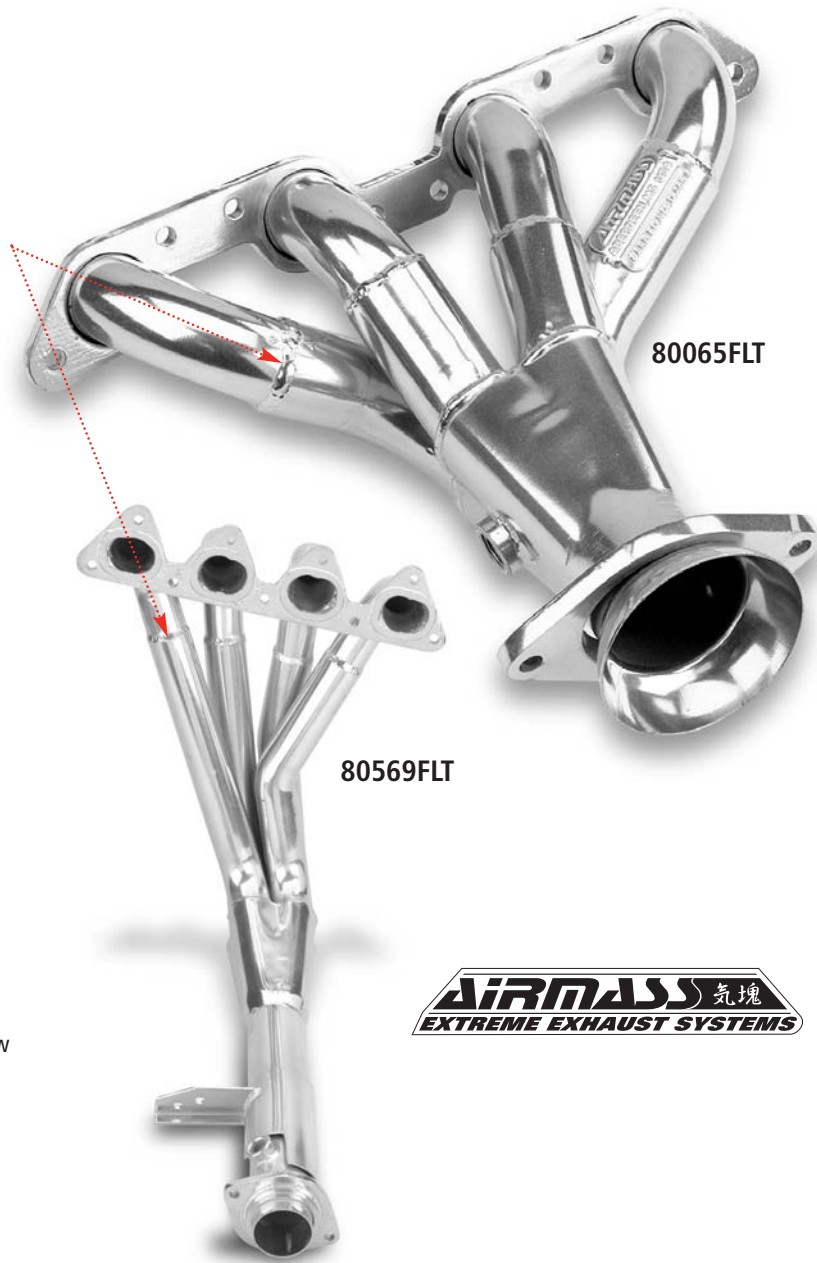

**AIRMASS** 氣塊  
EXTREME EXHAUST SYSTEMS

### AIRMASS PRO-STEP HEADERS

Make	Model	Year*	Painted	COMPBLU™	SHOCROM™	
ACURA	INTEGRA 1.8L	94-99 <sup>(3)</sup>				80567FLT
ACURA	INTEGRA 1.8L GSR	97-99 <sup>(3)</sup>		80168FLT	80068FLT	80568FLT
DODGE	NEON 2.0L SOHC	95-97 <sup>(3)</sup>			80065FLT	
DODGE	NEON 2.0L DOHC	95-97 <sup>(3)</sup>			80066FLT	80566FLT
HONDA	CIVIC, CRX 1.6L EX	96-99 <sup>(3)</sup>		80169FLT		

3 Must modify stock exhaust to retain catalytic converters.

# GET YER *Red Hots!*

## High Performance Glass Pack Mufflers

Red Hots from Flowtech may be the best muffler value on the market today. The classic design includes thick, long-lasting, high heat Cerama-Glass packing wrapped around a power louver baffle. Backpressure is decreased to increase flow, help boost power and they sound **RED HOT!**

Red Hots are only available in a rich red finish, In your choice of 2", 2 1/4" and 2 1/2" outlet diameters.

- Delivers Rich, powerful, **RED HOT** sound!
- Low backpressure to increases performance
- Large diameter 3.5" case
- **RED HOT** looks, **RED HOT** Value

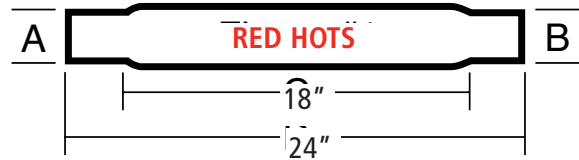

DESCRIPTION	PACKAGED	P/N	"A"	"B"
Slip-fit Muffler	each	50250FLT	2"	2"
Slip-fit Muffler	each	50251FLT	2-1/4"	2-1/4"
Slip-fit Muffler	each	50252FLT	2-1/2"	2-1/2"

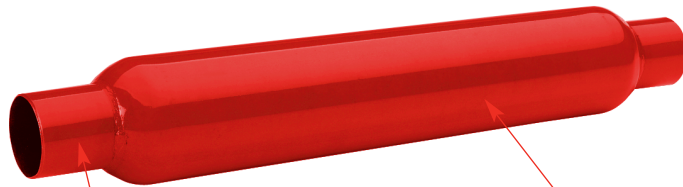

Look for the Red Hots on display at your favorite auto parts store!

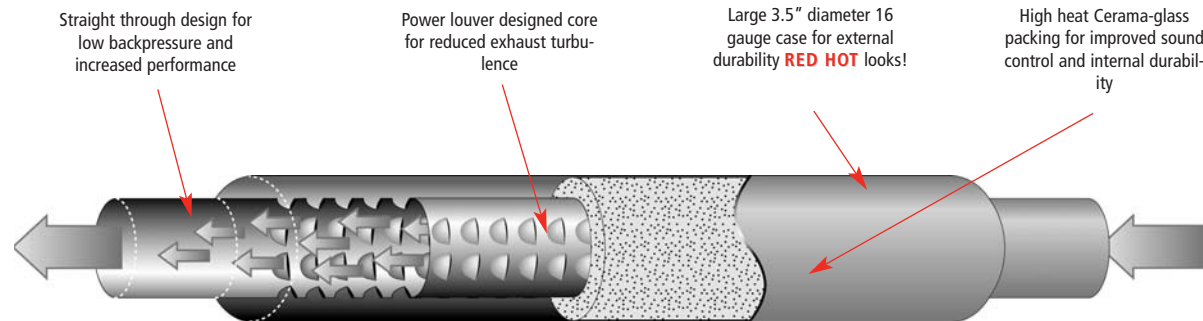

Straight through design for low backpressure and increased performance

Power louver designed core for reduced exhaust turbulence

Large 3.5" diameter 16 gauge case for external durability **RED HOT** looks!

High heat Cerama-glass packing for improved sound control and internal durability

- EG HEADERS
- FULL LENGTH HEADERS
- BLOCK HUGGER HEADERS
- RACE HEADERS
- IMPORT HEADERS
- GLASS PACK MUFFLERS**
- TURBO-STYLE MUFFLERS
- IMPORT MUFFLERS
- CATBACKS
- H-PIPES & X-PIPES
- TIPS
- COMPONENTS & ACCESSORIES
- MERCHANDISING
- PHOTO GALLERY PART # INDEX

### Have You Got The Purple Hornies?

The classic Purple Hornie tubular design glasspack mufflers give sound and performance gains that are more than impressive — they're wild! The 16-gauge, 3 1/2" diameter steel shell encloses an interior spiral louver baffle design that increases exhaust velocity while decreasing backpressure, projecting the sound waves into a temperature fibermat material. Available in an 18" case length with 2 1/4" slip-fit or choose from three different styles of 3" three-hole direct-header-mount designs.

- Rich, powerful sound
- Decreases backpressure, boosts horsepower
- 3 1/2" diameter 16-gauge case
- Spiral louver design core
- Distinctive purple finish

# PURPLE HORNIES™

DESCRIPTION	PACKAGED	P/N	FIGURE "A"	"B"	"C"	"D"
Slip-fit Muffler 3" 3-Hole	each	50225FLT	1	2-1/4"	2-1/4"	18" 24"
Header Muffler 3" 3-Hole Turn	each	50230FLT	2	3-hole	2-1/4"	18" 24"
Header Muffler 3" 3-Hole Jeep	each	50231FLT	3	3-hole	3"	29" 32"
Header Muffler	pair	50232FLT	4	3-hole	3"	29" 32"

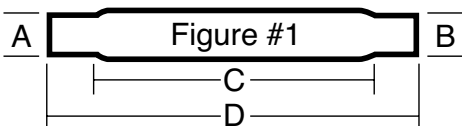

Figure 1

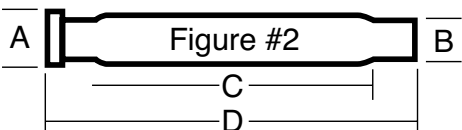

Figure 2

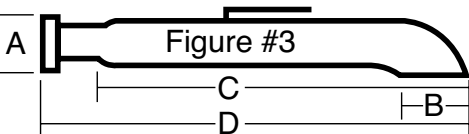

Figure 3

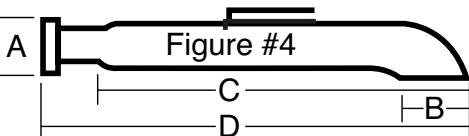

Figure 4

## Make Magic with Warlock™ Mufflers!

FlowTech's Warlock racing muffler may be too much for mere mortals. The high flow, low-restriction patented 3-pass-tube design provides lots of horsepower and a mean 'n nasty sound. But, when you're ready to battle the titans on the track, the Warlock lets you remove its Flow Intensifier™ bypass cap for un-restricted, unbelievable straight-through power!

- Removable Flow Intensifier offers maximum performance for street or strip
- Fully-welded 16-gauge ribbed case for added strength and reduced resonance
- Unique spiral-louvered pass tubes, no glass or seams to blow out

## Attention Racers!

This Warlock is ideal for both street and competition vehicles where mufflers are required. For specific racing requirements, check your rule book. Available with inlet sizes ranging from 2 1/4" up to a huge 3"!



PATENTED DESIGN

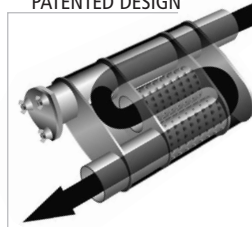

For street use, Flow Intensifier directs the flow of exhaust through giant, louvered pass tubes for sound control ...

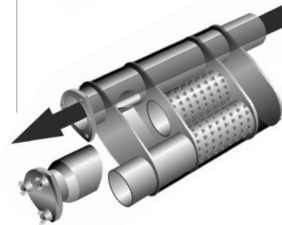

...But with Flow Intensifier removed, the Warlock provides a straight-through exhaust passage for super-natural power at the track!

Figure #1

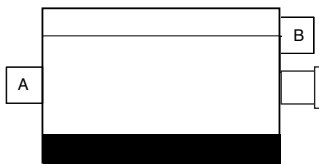

Figure #2



A= inlet  
B=outlet

### WARLOCK "BYPASS" SERIES RACING MUFFLERS

APPLICATIONS	P/N	FIGURE	"A"	"B"
w/ 2-1/2" BYPASS PLATE	50522FLT	1	2-1/2"	2-1/2"
w/ 2-1/2" BYPASS PLATE	50551FLT	2	2-1/4"	2-1/4"
w/ 2-1/2" BYPASS PLATE	50552FLT	2	2-1/2"	2-1/2"
w/ 3" BYPASS PLATE	50560FLT	2	3"	3"

MUFFLER DIMENSIONS: 13" LONG x 10"WIDE x 4-1/2" HIGH

EG HEADERS

FULL LENGTH HEADERS

BLOCK HUGGER HEADERS

RACE HEADERS

IMPORT HEADERS

GLASS PACK MUFFLERS

TURBO-STYLE MUFFLERS

IMPORT MUFFLERS

CATBACKS

H-PIPES & X-PIPES

TIPS

COMPONENTS & ACCESSORIES

MERCHANDISING

PHOTO GALLERY PART # INDEX

# AFTERBURNER™

## MUFFLERS



### Sound Engineered for Optimum Performance!

If you really want great sound and maximum horsepower, kick on the Afterburner -- and kick a little butt. FLOWTECH Afterburner mufflers are your very best bet for optimum performance and awesome sound. All Afterburners are made with an aluminized case for miles and miles of rust and corrosion protection. Their fully-welded construction offers stronger seams to prevent blow out under extreme conditions. Huge flow tubes provide blistering horsepower, while the sound tuned chambers provide unbelievable sound and minimize annoying resonance. And, Afterburner mufflers are fully reversible, designed for maximum flow in either direction!

- **FULLY-WELDED CONSTRUCTION** — Seams will not blow out under any condition
- **ALUMINIZED CASE** — Rust and corrosion resistant for longer life
- **HUGE FLOW TUBES** — Provide blistering horsepower and performance
- **FULLY REVERSIBLE** — Designed for maximum flow in either direction
- **SOUND TUNED CHAMBERS** — Provide awesome powerful sound with minimal resonance

# AFTERBURNER™

## TURBO CHAMBER HEADERS™

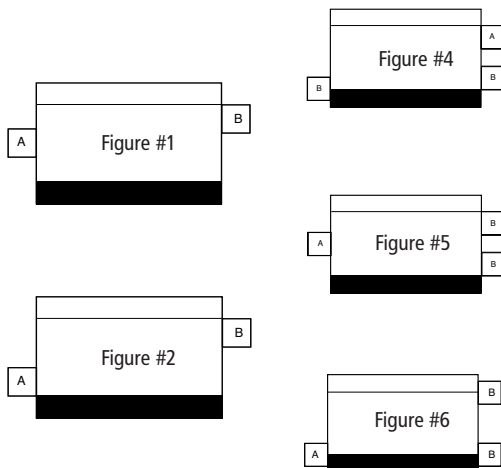
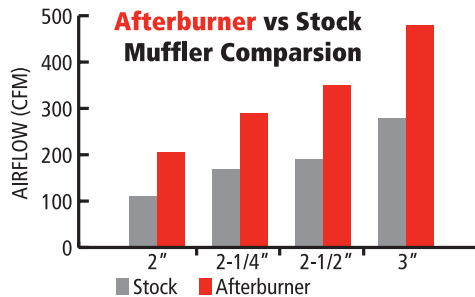

APPLICATIONS	P/N	FIGURE	"A"	"B"
UNIVERSAL PERFORMANCE	<b>50320FLT</b>	1	2"	2"
UNIVERSAL PERFORMANCE	<b>50321FLT</b>	1	2-1/4"	2-1/4"
UNIVERSAL PERFORMANCE	<b>50322FLT</b>	1	2-1/2"	2-1/2"
UNIVERSAL PERFORMANCE	<b>50330FLT</b>	1	3"	3"
UNIVERSAL PERFORMANCE	<b>50362FLT</b>	6	3"	2) 2-1/2"
MUSTANG 5.0L GT/LX	<b>50351FLT</b>	2	2-1/4"	2-1/4"
MUSTANG 5.0L GT/LX	<b>50352FLT</b>	2	2-1/2"	2-1/2"
CAMARO/FIREBIRD 82-95	<b>50363FLT</b>	4	3"	2) 2-1/2"
CHEVY/GMC PICKUP 88-95	<b>50370FLT</b>	5	3"	2) 2-1/2"
FORD PICKUP 88-95	<b>50371FLT</b>	5	2-1/2"	2) 2-1/2"

**MUFFLER DIMENSIONS: 13" LONG x 10" WIDE x 4" HIGH**

A= inlet  
B=outlet

## Get Ripped with Raptor™!

If you want a mean muffler that won't tear the guts from your wallet, get a Raptor -- and watch out! FLOWTECH's Raptor Turbo Performance Muffler features a sturdy aluminized case with lock seal construction. It offers gigantic, high-output flow tubes to provide more horsepower, better mileage, and a sound of pure performance!

- Free-flowing inner pass tubes — up to 3" in diameter
- Low restriction, reduces backpressure and increases performance over a broad power curve
- Heavy gauge case for durability and sound control
- Great performance tone



INLET SIZE	OUTLET SIZE	P/N	DESCRIPTION
2"	2"	<b>50050FLT</b>	Universal Performance Muffler
2-1/4"	2-1/4"	<b>50051FLT</b>	Universal Performance Muffler
2-1/2"	2-1/2"	<b>50052FLT</b>	Universal Performance Muffler
3"	3"	<b>50054FLT</b>	Universal Performance Muffler w/ 3" core <b>NEW</b>

**MUFFLER DIMENSIONS: 13"LONG x 10"WIDE x 4-1/2" HIGH**



EO HEADERS

FULL LENGTH HEADERS

BLOCK HUGGER HEADERS

RACE HEADERS

IMPORT HEADERS

GLASS PACK MUFFLERS

TURBO-STYLE MUFFLERS

IMPORT MUFFLERS

CATBACKS

H-PIPES &amp; X-PIPES

TIPS

COMPONENTS &amp; ACCESSORIES

MERCHANDISING

 PHOTO GALLERY  
 PART # INDEX

# TERMINATOR™

## MUFFLERS



# TERMINATOR™

## THE BAD BOY OF MUFFLERS

### FLOWTECH'S TERMINATOR™ NOT ONLY LOOKS BAD, IT IS BAD!

The Terminator is constructed entirely of super thick, fully-welded aluminized steel, with huge 3" inner pass tubes that reduce backpressure and increase horsepower like no other muffler can. Put a couple of Terminators behind your power-plant and you'll hear a bark that will scare the meanest junk yard dog in town!

- Fully-welded for strength and durability
- No glass to burn or blow out
- Thick aluminized steel construction
- Designed to flow in either direction

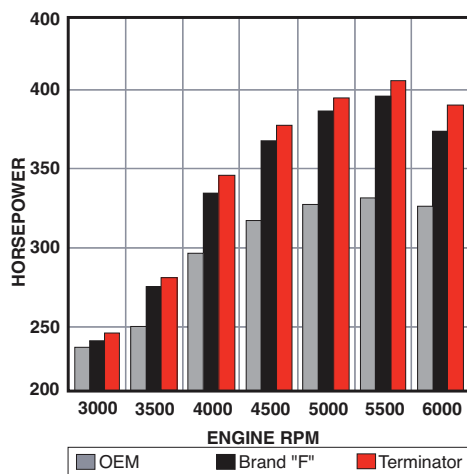

APPLICATIONS	PART NUMBER	FIG#	"A"	"B"
UNIVERSAL REPLACEMENT	50121FLT	1	2-1/4"	2-1/4"
UNIVERSAL REPLACEMENT	50122FLT	1	2-1/2"	2-1/2"
UNIVERSAL REPLACEMENT	50130FLT	1	3"	3"
MUSTANG 5.0L GT/LX	50151FLT	2	2-1/4"	2-1/4"
MUSTANG 5.0L GT/LX	50152FLT	2	2-1/2"	2-1/2"
05 MUSTANG MUFFLER SET W/ TIPS	50253FLT	5	2-1/2"	3"
CAMARO/FIREBIRD 82-92	50162FLT	3	2-1/2"	2) 2-1/2"
CHEVY/GMC PICKUPS 88-95	50170FLT	4	3"	2) 2-1/2"

**MUFFLER DIMENSIONS: 15" LONG X 11" WIDE X 5" HIGH**

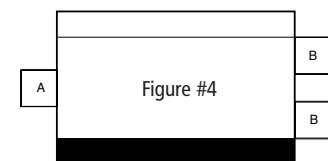
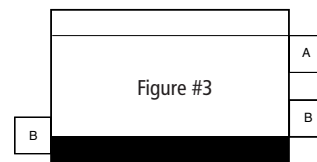
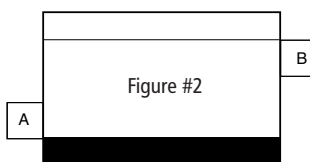
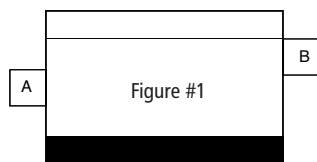

A= inlet  
B=outlet

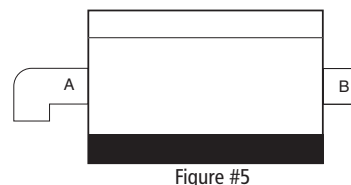



# STINGER™

## EXHAUST SYSTEMS

### Sting for Your 'Stang!

Get more power from your 5.0L pony with FLOWTECH's Stinger Cat-Back exhaust system. Your new Stinger system will boost horsepower, increase performance and even help improve fuel economy. Easily installed in the stock location, the system includes mandrel-bent, 2 1/2" flow tubes, 2 1/2" Warlock mufflers, turndowns and all mounting hardware.



Stinger system shown with optional by-pass muffler

P/N	YEAR	APPLICATION	DESCRIPTION
<b>STINGER EXHAUST SYSTEM WITH WARLOCK MUFFLERS</b>			
42600FLT	86-95	Mustang 5.0L GT/LX	2-1/2" Stinger System with Warlock Mufflers
42601FLT	86-95	Mustang 5.0L GT/LX	2-1/2" Stinger System with Warlock By-Pass Mufflers



### Bang for Your 'Stang

This FLOWTECH Terminator is specifically designed for the Mustang 5.0L. The super, heavy duty, fully-welded flow system has multiple chambers and huge 3" flow tubes.

NOTE: The Mustang Terminator looks bad, sounds bad, and IS so bad that we recommend it for off road and race track use only!

- Awesome sound of power
- Reduced backpressure
- Aluminized, thick steel construction
- Fully-welded inside and out
- No glass packing to burn out

P/N	INLET SIZE	OUTLET SIZE	CASE	APPLICATION
<b>STINGER EXHAUST SYSTEM WITH TERMINATOR MUFFLER</b>				
50151FLT	2-1/4"	2-1/4"	OFFSET/OFFSET	MUSTANG 5.0L
50152FLT	2-1/2"	2-1/2"	OFFSET/OFFSET	MUSTANG 5.0L

<b>AFTERBURNER MUFFLERS</b>				
50351FLT	2-1/4"	2-1/4"		MUSTANG 5.0L GT/LX
50352FLT	2-1/2"	2-1/2"		MUSTANG 5.0L GT/LX

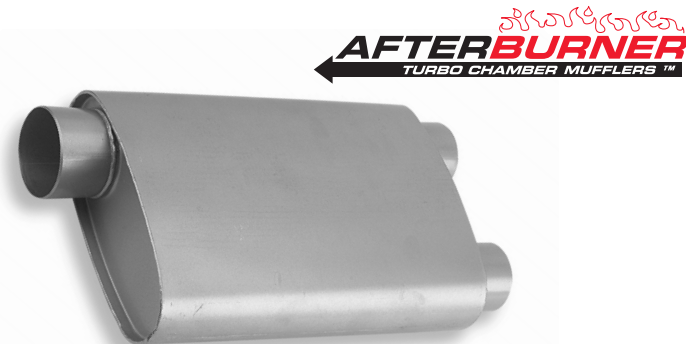

If you really want great sound and maximum horsepower, kick on the Afterburner -- and kick a little butt.

- Fully-welded construction
- Aluminized case
- huge flow tubes
- Fully reversible
- Sound tuned chambers

- EO HEADERS
- FULL LENGTH HEADERS
- BLOCK HUGGER HEADERS
- RACE HEADERS
- IMPORT HEADERS
- GLASS PACK MUFFLERS
- TURBO-STYLE MUFFLERS
- IMPORT MUFFLERS
- CATBACKS
- H-PIPES & X-PIPES
- TIPS
- COMPONENTS & ACCESSORIES
- MERCHANDISING
- PHOTO GALLERY PART # INDEX

## 2005-06 MUSTANG GT TERMINATOR MUFFLERS



### 2005-06 Mustang GT Terminator Muffler Set

Pull the plug on the competition with these new Terminators. Flowtech has just made this leading performance muffler available for the 2005-06 Mustang with the 4.6L V8 for the first time. This high flow muffler set bolts right on to the Mustang and with their cool black finish will keep this pony ride in "sleeper" mode.



- High flow mufflers designed for reduced back pressure
- Huge 3" inner pass tubes tuned for increased horse power and performance
- Deep, aggressive performance tone
- Sturdy, fully welded aluminized cases are designed for long life
- Black finish hides muffler for the "sleeper" look
- Polished 304 slash cut stainless tips enhance the Mustang's performance image
- Muffler clamps and hardware included for an easy installation

PART #	DESCRIPTION
50253FLT	Flowtech 2005 Mustang Terminator muffler set with tips



## Get More Power and Sound with Warlock™ Cat-Back Systems!

FLOWTECH presents the best and easiest way to get more power and unbelievable sound from your Mustang. These Cat-Back systems include everything you'll need to bolt on super horsepower gains in minutes. Features 2-1/2" mandrel-bent tubing for smooth flow. Installation is a snap, and these systems are legal in all 50 states!

- Fully-welded muffler
- High-flow mandrel-bent aluminized tubing
- Street-legal, bolt-on performance
- Powerful performance sound



### WARLOCK EMISSIONS LEGAL CAT-BACK SYSTEMS FOR CARS

APPLICATIONS	YEAR	ENGINE	PART NUMBER	EXIT DESCRIPTION	
MUSTANG 5.0L LX	86-93	5.0L	42604FLT	DUAL 2-1/2" REAR EXIT	⬇
MUSTANG 5.0L GT	86-93	5.0L	42605FLT	DUAL 2-1/2" REAR EXIT	⬇

- EG HEADERS
- FULL LENGTH HEADERS
- BLOCK HUGGER HEADERS
- RACE HEADERS
- IMPORT HEADERS
- GLASS PACK MUFFLERS
- TURBO-STYLE MUFFLERS
- IMPORT MUFFLERS
- CATBACKS**
- H-PIPES & X-PIPES
- TIPS
- COMPONENTS & ACCESSORIES
- MERCHANDISING
- PHOTO GALLERY PART # INDEX

# TRUCK TOOBS™

## CATBACKS



### Get That Muscle Car Look and Sound With A Set of Rear-Exit Truck TOOBS™ from FlowTech!

Truck TooBS rear-exit exhaust systems feature left and right exits and high-flowing, fully-welded Afterburner™ muffler. Mandrel-bent aluminized tubing and a muffler with no glass to burn or blow out means miles and miles of sound and performance for all sport trucks, work trucks, 4X4's and slammer trucks.

- Fully-welded Afterburner™ muffler
- Aluminized muffler case for long life
- High-flow mandrel-bent aluminized tubing
- Street-legal, bolt-on performance
- OEM-style connections for easy installation
- All mounting hardware included
- Installs behind the catalytic converter
- OEM style connections for easy installation
- Dual right and left rear exits
- All hardware included
- No fabrication necessary
- Fully-welded mufflers included

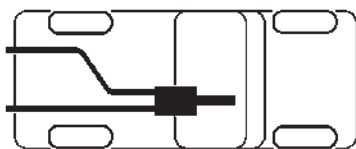

Installs behind catalytic converter using OEM-style connections for easy installation

# AFTERBURNER TRUCK TOOBS™

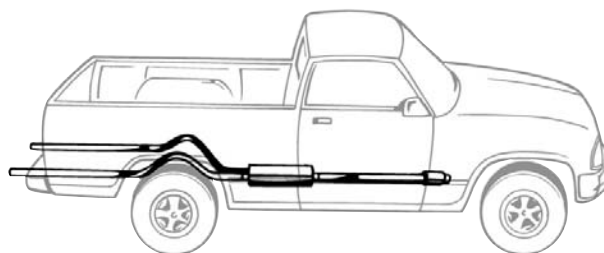

VEHICLE	YEAR	ENGINE	2/4 WD	APPLICATION	PART NUMBER	TAIL SIZE	FOOTNOTES
<b>CHEVROLET/GMC</b>							
PICKUP	88-93	350	2/4	EXT CAB SHORT BED	62106FLT	2-1/2"	A,C,E,F,H
PICKUP	88-93	350	2/4	STD CAB SHORT BED	62100FLT	2-1/2"	A,C,E,F,H
PICKUP	1990	454	2	STD CAB SHORT BED	62100FLT	2-1/2"	A,C,E,F,H
PICKUP	94-95	4.3,305,350	4	EXT CAB SHORT BED	62110FLT	2-1/2"	B,D,E,F,H
<b>FORD</b>							
F150/250	87-96	4.9L,302,351	2/4	STD CAB SHORT BED	62400FLT	2-1/2"	G
<b>DODGE</b>							
RAM 1500	94-97	6CYL,318,360	2/4	STD/EXT CAB S/L BED	62800FLT	2-1/2"	E,I

#### INSTALLATION NOTES

Y = YES, N = NO, O = NOT VERIFIED

- |   |  |   |  |
|---|--|---|--|
| A | For stock dual outlet.                         | F | Split exit, 1500&2500 series with one stock converter. |
| B | For 93-95 vehicles with single exhaust outlet. | G | Will not fit 250HD with one converter.                 |
| C | For slip-fit behind the stock converter.       | H | Some lowered trucks may require rear shock relocators. |
| D | For flange-fit behind the stock converter.     | I | Dual Rear Kit, Passenger side                          |
| E | Will not fit 250HD series.                     |   |  |

## Flowtech Turbo Back Diesel Truck Exhaust Systems

Flowtech's big and tough 4" diesel truck exhaust systems provide increased exhaust flow, a reduction in back pressure and lower EGTs. This means more power and longer engine life.

They are a bolt-in replacement for the restrictive factory exhaust and include all the necessary clamps, hardware, hangers and tips. Also packed in to each system are comprehensive instructions written for the home mechanic. Flowtech's turbo back exhaust systems are big and brutal, so we recommend the installer also have a helper on hand.

### FEATURES/BENEFITS:

- Manufactured from sturdy 16 gauge aluminized steel to resist corrosion
- All tubing mandrel bent to ensure smooth exhaust flow.
- Robotic welds ensure leak-free construction
- Free-flow 7" muffler reduces back pressure for improved torque
- Perforated muffler exhibits aggressive yet mellow "big rig" diesel sound.
- Big 4" tube reduces harmful exhaust gas temperatures for longer engine and turbocharger life.
- Systems are easy to install and include all the components necessary for installation on any cab/bed/chassis configuration
- Includes polished, slash cut 4" to 5" stainless steel tip(s)



PART #	DESCRIPTION	DIMENSIONS	WEIGHT
62851FLT	94-02 Dodge 5.9L Cummins QC/LB, aluminized, single outlet, w/ single tip	48" x 21" x 13"	95LBS.
62852FLT	94-02 Dodge 5.9L Cummins QC/LB, aluminized, dual outlet, w/ dual tips	48" x 21" x 13"	98LBS.
62451FLT	1999-02 Ford F-250/350 7.3L PS, aluminized, single outlet, w/ single tip	48" x 21" x 13"	95LBS.
62452FLT	1999-02 Ford F-250/350 7.3L PS aluminized, dual outlet, w/ dual tip	48" x 21" x 13"	98LBS.
62151FLT	01-04 GM Duramax 6.6L XC/LB, CC/SB, CC/LB, aluminized, single outlet	48" x 21" x 13"	95LBS.
62152FLT	01-04 GM Duramax 6.6L XC/LB, CC/SB, CC/LB, aluminized, dual outlet	48" x 21" x 13"	98LBS.

- EG HEADERS
- FULL LENGTH HEADERS
- BLOCK HUGGER HEADERS
- RACE HEADERS
- IMPORT HEADERS
- GLASS PACK MUFFLERS
- TURBO-STYLE MUFFLERS
- IMPORT MUFFLERS
- CATBACKS
- H-PIPES & X-PIPES
- TIPS
- COMPONENTS & ACCESSORIES
- MERCHANDISING
- PHOTO GALLERY PART # INDEX

# MUFFLERS & CATBACKS

## SPORT COMPACT EXHAUST SYSTEMS



### Warlock™ CAT-BACK EXHAUST SYSTEMS

Warlock Cat-Back Systems for Street and Strip feature a high-flow, triple-pass-tube muffler and big-bore 16-gauge constant cross section tubing to give your Honda or Acura maximum exhaust flow with no restrictions. The Warlock makes a sound so wicked, it blisters the competition!

- Bolts directly to OEM system with no modifications
- Fully polished 304 stainless oval triple pass-tube racing muffler is fully welded, with no glass or seams to blow out
- Large 4 1/2" stainless steel rolled lip tip welded in place
- Constructed of big bore constant cross section 16-gauge aluminized tubing
- Huge 2 1/4" tubing provides low back pressure for your Honda and Acura
- Includes all mounting hardware
- Easy to install, goes on in minutes



MAKE	MODEL	YEAR	PART NUMBER
ACURA	INTEGRA HATCHBACK	90-91	81000FLT
ACURA	INTEGRA HATCHBACK	92-93	81002FLT
ACURA	INTEGRA 2DR, GSR,	94-00	81004FLT
HONDA	ACCORD 2/4 DR	94-97	81030FLT
HONDA	ACCORD 2DR 4 CYL VTEC	98-00	81034FLT
HONDA	ACCORD 4DR 4 CYL VTEC	98-00	81035FLT
HONDA	CIVIC SI	88-91	81022FLT
HONDA	CIVIC SI HATCHBACK	92-95	81024FLT
HONDA	CIVIC COUPE/4DR, EX, LX, DX	92-95	81026FLT
HONDA	CIVIC COUPE/4DR EX ONLY	96-00	81028FLT
HONDA	CRX SI	88-91	81020FLT

### Universal Fit REPLACEMENT MUFFLER

- Special high-flow spiral pin-louvered core for increased exhaust flow
- High velocity air-gap cover tube
  - a) Increases sound-wave control
  - b) Protects packing from direct exhaust heat which causes premature burnout
  - c) Better flow with ZERO turbulence
- 1600° F High-heat Ceramic Glass™ packing for durability
- Fully-welded, .065 stainless steel 7.5" round case for durability and an aggressive look
- 5" Polished stainless steel exhaust tip



**AIRMASS**  
*Thunder* **MUFF**

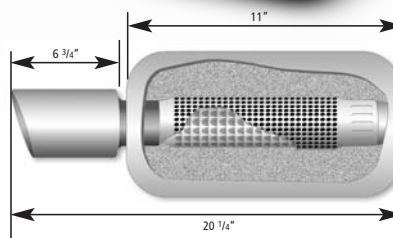

#### AIRMASS THUNDERMUFF™ UNIVERSAL REPLACEMENT MUFFLERS

UNIVERSAL FIT

NO HANGERS

82490FLT

**If you want to feel more power and hear a meaner sound, bolt on a ThunderMuff™!**

ThunderMuff Catback Systems are engineered to make just about any Honda, Acura or Mitsubishi run stronger and sound better. The big-bore tubing and polished stainless steel muffler combine to give you maximum power, the best sound, and the most awesome looks around!

- Bolts directly to OEM system with no modifications
- Fully polished and welded 304 stainless case for ultimate styling and durability
- Huge 5" stainless 10 degree angle cut tip, welded in place
- Constructed of big bore 2 1/2" 16-gauge aluminized tubing (Eclipse Turbo 3")
- Includes all mounting hardware



**AIRMASS**  
*Thunder* **MUFF**

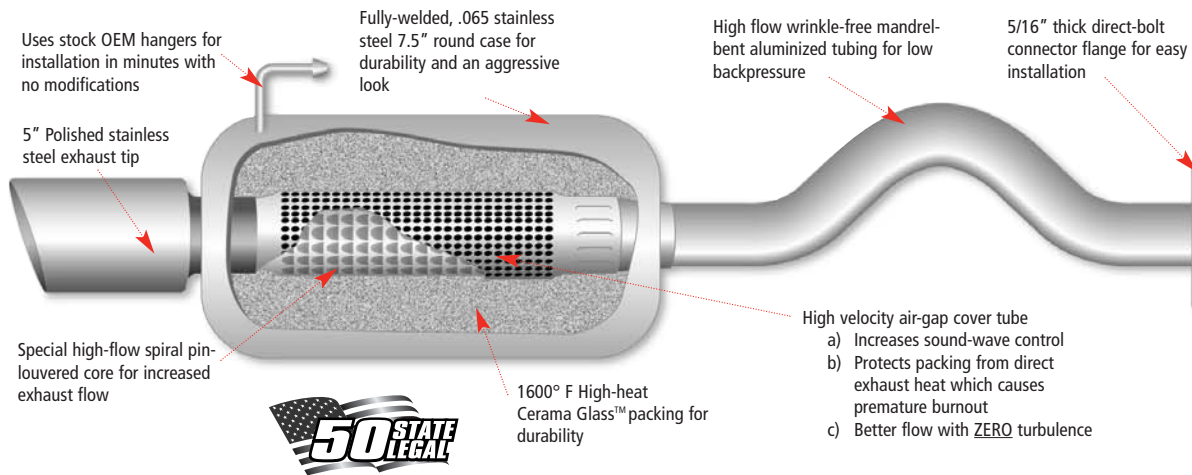

MAKE	MODEL	YEAR	PART NUMBER
ACURA	INTEGRA 2 DR, GSR,	94-00	<b>81404FLT</b>
HONDA	ACCORD 2/4 DR	94-97	<b>81430FLT</b>
HONDA	ACCORD 2DR 4 CYL VTEC	98-00	<b>81434FLT</b>
HONDA	ACCORD 4DR 4 CYL VTEC	98-00	<b>81435FLT</b>
HONDA	CIVIC COUPE/4DR, EX, LX, DX	92-95	<b>81426FLT</b>
HONDA	CIVIC COUPE/4DR EX ONLY	96-00	<b>81432FLT</b>
MITSUBISHI	ECLIPSE GST	95-99	<b>81462FLT</b>
MITSUBISHI	ECLIPSE RS, GS	95-99	<b>81464FLT</b>

- EO HEADERS
- FULL LENGTH HEADERS
- BLOCK HUGGER HEADERS
- RACE HEADERS
- IMPORT HEADERS
- GLASS BACK MUFFLERS
- TURBO-STYLE MUFFLERS
- IMPORT MUFFLERS
- CATBACKS**
- H-PIPES & X-PIPES
- TIPS
- COMPONENTS & ACCESSORIES
- MERCHANDISING
- PHOTO GALLERY PART # INDEX

# SUPER STREET DUAL KIT

## CATBACKS



### Want More Power and Sound? Then Slap On A Super Street Dual Kit!



FLOWTECH® Super Street Exhaust Kits offer a top quality, custom fit dual exhaust system at a price that couldn't be more affordable. Kits include everything from the header flange back to the tailpipe, excluding mufflers. These heavy duty 16-gauge systems offer the maximum in versatility. Available for either header or stock manifold applications, FLOWTECH Super Street Dual Kits were designed to locate all components above the frame. All systems feature OEM exit locations and all parts and instructions are included.

- Fixture-formed 2 1/4" 16-gauge tubing for increased performance
- Custom fit for both factory manifolds and aftermarket headers
- Kits include all hardware and installation instructions

NOTE: Super Street Dual Kits do not include mufflers. See application chart for recommended FLOWTECH muffler.

APPLICATION	YEAR	ENGINE	HEADER DUAL KIT	MANIFOLD DUAL KIT	USE W/ FLOWTECH HEADER	USE W/ TERMINATOR MUFFLER	USE W/ RAPTOR MUFFLER	TUBE SIZE	FOOTNOTES
<b>CHEVROLET PASSENGER EXHAUST KITS</b>									
CAMARO & Z/28	70-81	283-400	51555FLT	-	11100FLT	50121FLT	50051FLT	2-1/4"	100
<b>CHEVROLET/GMC TRUCK EXHAUST - FOUR WHEEL DRIVE ONLY</b>									
PU 1/2, 3/4, 1 TON	73-87	305-400	51525FLT	52525FLT	11500FLT	50121FLT	50051FLT	2-1/4"	
SUBURBAN	73-87	305-400	51525FLT	52525FLT	11500FLT	50121FLT	50051FLT	2-1/4"	

#### INSTALLATION NOTES

Y = YES, N = NO, O = NOT VERIFIED

100 Will work with factory exhaust system.



## OFF-ROAD MUSTANG H-PIPES AND STARTER TUBES

Not for everyone, FLOWTECH'S off-road-only H-Pipe is specifically designed for drag racing, slaloms, road racing and trials competition.

- Aluminized tubing
- OEM hangers
- Large 2 1/2" diameter tubing

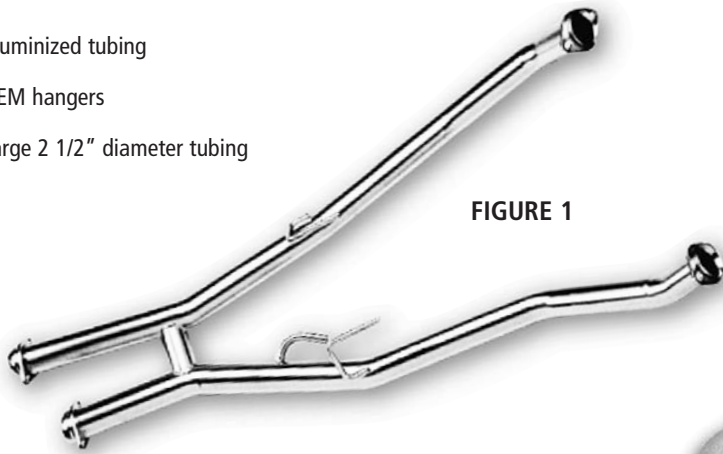

FIGURE 1

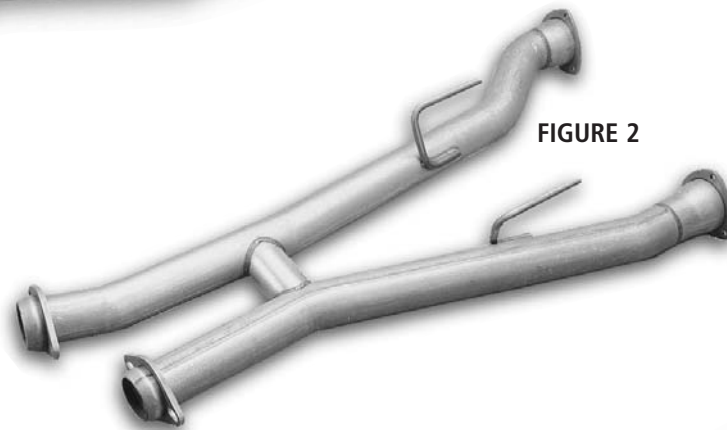

FIGURE 2



FIGURE 3

APPLICATION	YEAR	ENGINE	PART NUMBER	FIGURE
<b>PRO-STANG OFF-ROAD H-PIPE APPLICATIONS</b>				
MUSTANG GT	96-98	4.6L	53607FLT	1
MUSTANG GT	99-01	4.6L	53604FLT	1
MUSTANG GT/LX	86-93	5.0L	53605FLT	1
MUSTANG GT	94-95	5.0L	53606FLT	1
MUSTANG (for use w/ 12104)	79-93	5.0L	53608FLT	2
<b>PRO-STANG STARTER TUBE APPLICATIONS</b>				
MUSTANG GT/LX	86-93	5.0L	53609FLT	3

EO HEADERS

FULL LENGTH HEADERS

BLOCK HUGGER HEADERS

RACE HEADERS

IMPORT HEADERS

GLASS PACK MUFFLERS

TURBO-STYLE MUFFLERS

IMPORT MUFFLERS

CATBACKS

H-PIPES & X-PIPES

TIPS

COMPONENTS & ACCESSORIES

MERCHANDISING

PHOTO GALLERY PART # INDEX

# X-TERMINATOR® CROSS PIPES

## X-PIPES



### Get the X-Factor!

X-Terminator® Off-Road Cross Pipes are designed specifically for standard transmission Ford Mustangs. This unique cross pipe configuration offers more horsepower, a meaner sound and an X-treme advantage for Mustangs competing in drag racing, road racing, slaloms, trials and more!

- Mandrel bent 16 gauge aluminized tubing
- Large 2½" and 3" diameters for greater flow and increased performance
- Direct bolt-on design for late model Mustangs
- Universal designs in popular 2½" and 3" outlets
- More horsepower than factory H-pipes
- Awesome and distinctive sound
- Manual trans application only

# X-TERMINATOR®

## Off Road Cross Pipes



APPLICATION	YEAR	ENGINE	PART NUMBER
<b>X-TERMINATOR OFF ROAD CROSS PIPES - SPECIFIC FIT</b>			
MUSTANG	86-93	5.0L	53625FLT 3
MUSTANG*	79-93	5.0L	53628FLT 3
MUSTANG	94-95	5.0L	53626FLT 3
MUSTANG (2 VALVE)	96-98	4.6L	53627FLT 3
MUSTANG (2 VALVE)	99	4.6L	53624FLT 3
X-PIPE FOR 12115FLT	96-02	4.6L (2V)	12115YFLT 3
X-PIPE FOR 12114FLT	96-03	4.6L (4V)	12114YFLT 3

\* Fits header part numbers 12104 or 32104

## Universal Cross-Pipe Kits

Due to popular demand from non-Ford enthusiasts, Flowtech has introduced a line of universal X-Terminator cross pipes in 2 1/2" and 3" tube diameters.

- Adjustable cut-to-fit legs allows use on various applications and provides an easy installation
- Mandrel bent tubing for decreased backpressure and increased velocity
- Complete with collectors and u-bolts
- Great sound and performance

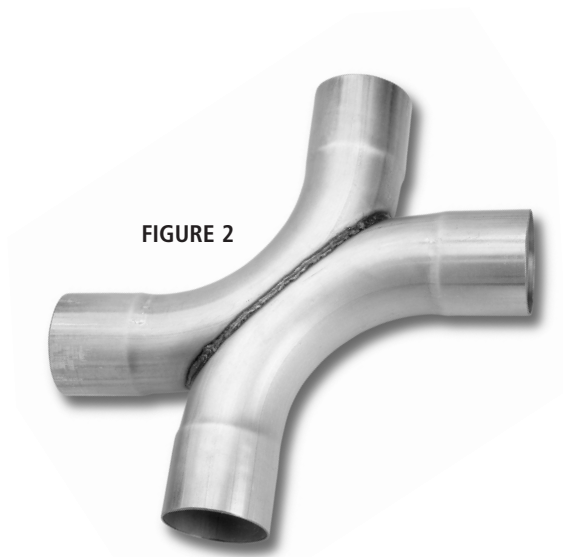

FIGURE 2

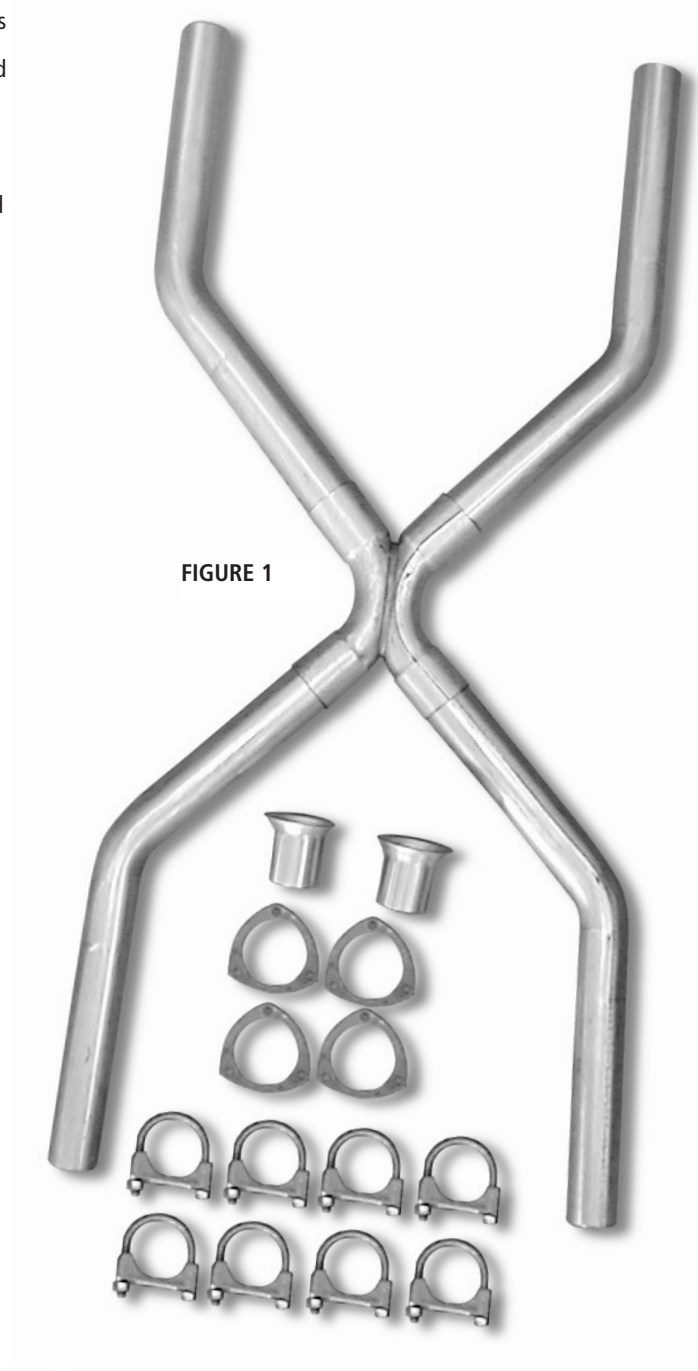

FIGURE 1

APPLICATION	PART#	FIGURE
CROSS-PIPE INSTALLATION KIT 2.5" DIAMETER 23" x 55"	53622FLT	1
CROSS-PIPE INSTALLATION KIT 3" DIAMETER 24" x 55"	53623FLT	1
<b>X-TERMINATOR OFF ROAD CROSS PIPES - UNIVERSAL (CROSS ONLY)</b>		
UNIVERSAL CROSS PIPE 2-1/2" DIAMETER	53620FLT	2
UNIVERSAL CROSS PIPE 3" DIAMETER	53621FLT	2

- EO HEADERS
- FULL LENGTH HEADERS
- BLOCK HUGGER HEADERS
- RACE HEADERS
- IMPORT HEADERS
- GLASS PACK MUFFLERS
- TURBO-STYLE MUFFLERS
- IMPORT MUFFLERS
- CATBACKS
- H-PIPES & X-PIPES
- TIPS
- COMPONENTS & ACCESSORIES
- MERCHANDISING
- PHOTO GALLERY PART # INDEX

## “Tip Off” Your Exhaust System With Terminator® Exhaust Tips!

The best exhaust systems start with FLOWTECH headers and mufflers, and they end with Terminator exhaust tips.

Terminator exhaust tips are ideal for any application, from stone-stock to highly modified for top performance and style. They're the perfect way to 'tip-off' the exhaust system on any import or domestic car, truck or van.

Terminator exhaust tips feature glass-packed resonators to reduce even the loudest exhaust to a sweet, mellow sound. All Terminator tips are polished and triple-process chrome plated and are available in Dual Outlet and Huge Hanna styles.

- Show quality chrome plating
- Durable black finish
- Can be welded or clamped on
- Complete the system!

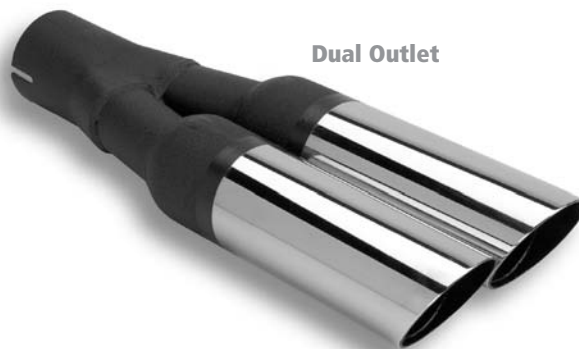

Dual Outlet



Huge Hanna

OUTLET DIA.	OVERALL LENGTH	TAILPIPE SIZE	PART NUMBER
<b>Dual Outlet w/ Resonator, Slash Cut Tip, Weld or Clamp-On</b>			
2-1/2"	15"	2"	<b>59904FLT</b>
2-1/2"	15"	2-1/4"	<b>59905FLT</b>
<b>Huge Hanna, Large Bore, Pencil Tip, Weld or Clamp-On</b>			
4"	9"	2"	<b>59324FLT</b>
4"	9"	2-1/4"	<b>59325FLT</b>

## Complete your system with Airmass accessories!

Airmass exhaust tips will provide a finishing touch to any exhaust system. The super polished, thick 16-gauge 304 STAINLESS STEEL Tips look sensational, and the non-resonated design means unrestricted sound and flow!



B

A

FIG.	DESCRIPTION	INLET SIZE	PART #
<b>POLISHED 304 STAINLESS TIPS - NON RESONATED</b>			
A	4.5" ROLLED LIP	2.25" INLET	<b>85045FLT</b>
B	4.5" 10 DEGREE ANGLE CUT	2.25" INLET	<b>85145FLT</b>

## Real-Seal™ Gaskets

FLOWTECH REAL-SEAL header and collector gaskets are a revolutionary break-through in exhaust sealing technology. Constructed of separate layers of "Dead Soft" aluminum, REAL SEALS provide a do-it-once solution that won't burn or blow out. REAL-SEAL gaskets will work when an o-ringed gasket won't because the "Dead Soft" aluminum conforms to create a leak-proof seal. REAL-SEALS can also be easily trimmed for port-matching and you can use them over and over again.

- Multi-Layer "Dead Soft" aluminum conforms to create a leak-proof seal
- Will not burn or blow out
- Suitable for port-matching
- Re-useable - probably the last gasket you will ever buy
- Water and weather resistant

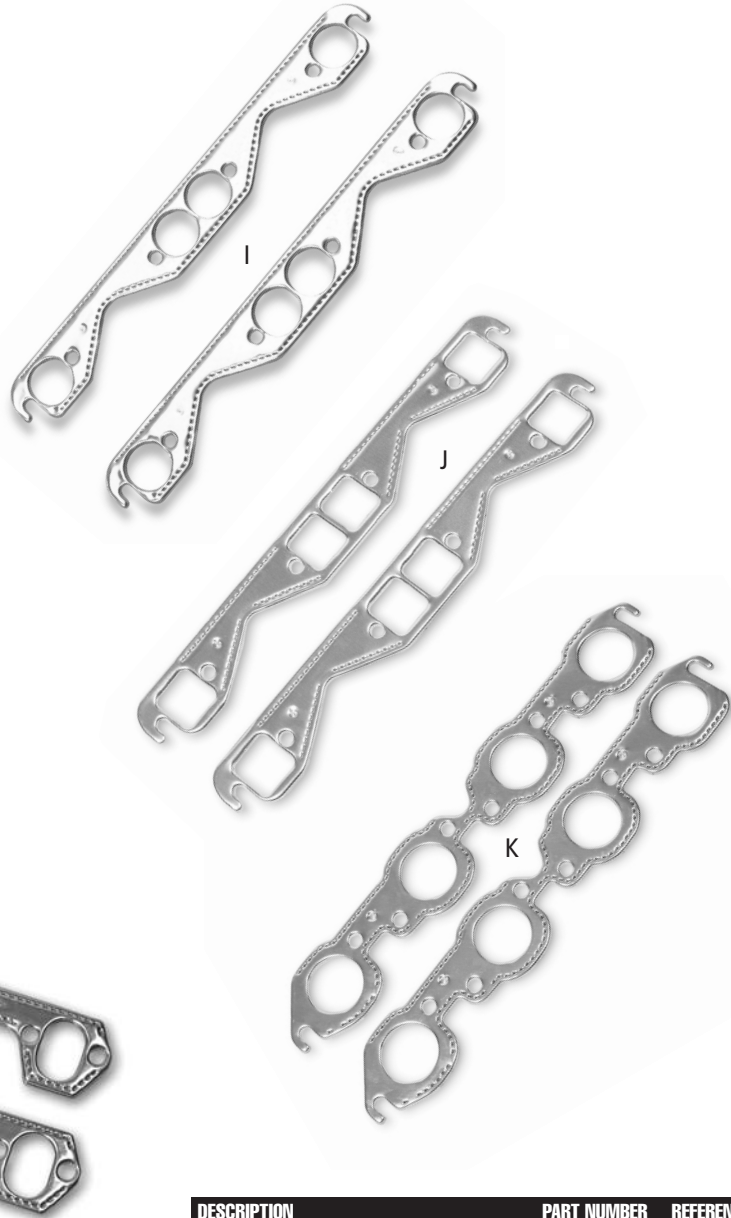

DESCRIPTION	PART NUMBER	REFERENCE
<b>REAL-SEAL™ GASKETS</b>		
<b>HEADER GASKETS</b>		
Small Block Chevy - Round Port*†	99150FLT	I
Small Block Chevy - Square Port*	99150AFLT	J
Big Block Chevy - Round Port*	99153FLT	K
Small Block Ford - Square Port*	99253FLT	L
Small Block Ford - Round Port*	99253RFLT	M
<b>COLLECTOR GASKETS</b>		
2 1/2" - 3 Hole Collector Gaskets	10024FLT	N
3" - 3 Hole Collector Gaskets	10025FLT	N
3 1/2" - 3 Hole Collector Gaskets	10026FLT	N

(\*) Fits only with port shape listed. Please verify port shape on header and match to proper gasket  
 (†) Fits with Short Smog Headers and Afterburner headers. Does not fit standard series Flowtech header

EO HEADERS
FULL LENGTH HEADERS
BLOCK HUGGER HEADERS
RACE HEADERS
IMPORT HEADERS
GLASS PACK MUFFLERS
TURBO-STYLE MUFFLERS
IMPORT MUFFLERS
CATBACKS
H-PIPES & X-PIPES
TIPS
COMPONENTS & ACCESSORIES
MERCHANDISING
PHOTO GALLERY PART # INDEX

**GASKETS**

## COMPONENTS &amp; ACCESSORIES

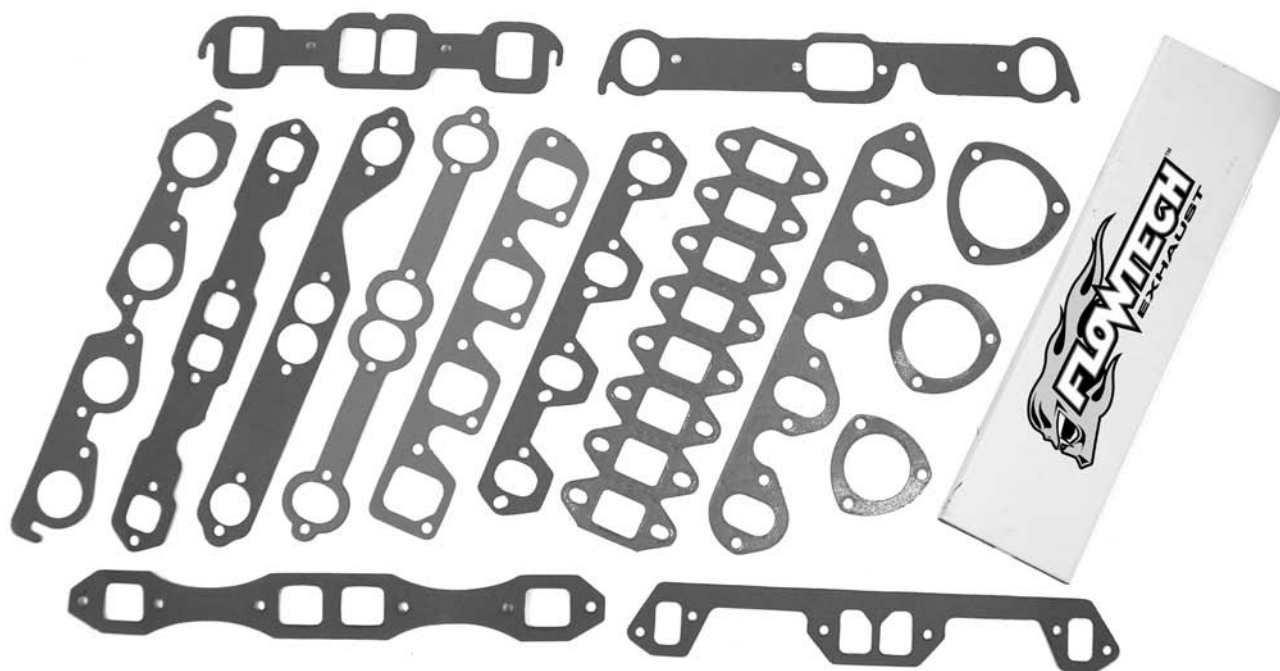

PART #	QTY. EA.	DESCRIPTION
<b>99160FLT</b>		<b>Gasket Set Chevy 283-400/EO/ Afterburner Headers</b>
	2	Head Flange Gaskets
	2	Collector Gaskets - 3"
<b>99161FLT</b>		<b>Gasket Set Chevy 283-400, full length headers</b>
	2	Head Flange Gaskets
	2	Collector Gaskets - 3"
	2	Collector Gaskets - 2.5"
<b>99162FLT</b>		<b>Gasket Set Chevy 396-454</b>
	2	Head Flange Gaskets
	2	Collector Gaskets - 3.5"
	2	Collector Gaskets - 3"
<b>99260FLT</b>		<b>Gasket Set Ford Cleveland M</b>
	2	Head Flange Gaskets
	2	Collector Gaskets - 3"
	2	Collector Gaskets - 2.5"
<b>99261FLT</b>		<b>Gasket Set Ford FE Truck</b>
	2	Head Flange Gaskets
	2	Collector Gaskets - 3"
	2	Collector Gaskets - 2.5"
<b>99262FLT</b>		<b>Gasket Set Ford 429-460</b>
	2	Head Flange Gaskets
	2	Collector Gaskets - 3"

PART #	QTY. EA.	DESCRIPTION
<b>99263FLT</b>		<b>Gasket Set Ford 302-351W</b>
	2	Head Flange Gaskets
	2	Collector Gaskets - 3"
<b>99264FLT</b>		<b>Gasket Set Ford 351 C - 2V</b>
	2	Head Flange Gaskets
	2	Collector Gaskets - 3"
<b>99360FLT</b>		<b>Gasket Set Chrysler 361-440</b>
	2	Head Flange Gaskets
	2	Collector Gaskets - 3"
<b>99361FLT</b>		<b>Gasket Set Chrysler 273-360</b>
	2	Head Flange Gaskets
	2	Collector Gaskets - 3"
<b>99460FLT</b>		<b>Gasket Set Oldsmobile 260-455</b>
	2	Head Flange Gaskets
	2	Collector Gaskets - 3"
<b>99560FLT</b>		<b>Gasket Set Pontiac 326-455</b>
	2	Head Flange Gaskets
	2	Collector Gaskets - 3"

## Get the Best of Both Worlds With Race Readies™ From FlowTech!

Race Readies let you keep your car or truck's exhaust system closed for the street, but wide open for the strip. And, since the caps are secured by just three wing nuts, you can realize maximum horsepower and performance in minutes! Race Readies include fully welded construction, 3/8" Grade 8 threaded studs, washers and gaskets, and are sold in pairs only.

- Race Readies twin pack includes free track tool
- Guaranteed not to leak
- Street legal to race ready in seconds
- Lower E.T.'s and more miles per hour
- COMPLETE INSTALLATION INSTRUCTIONS INCLUDED!

This device is intended for off-road racing only. It is not legal for use on pollution controlled motor vehicles that will be driven on public roads or highways.

# RACE READIES™

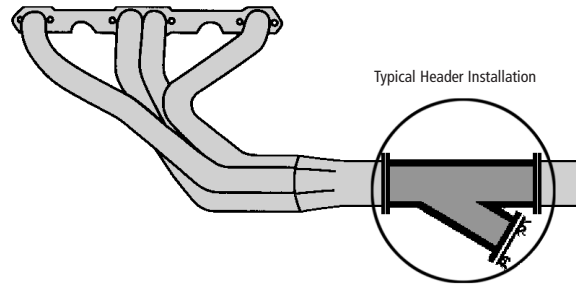
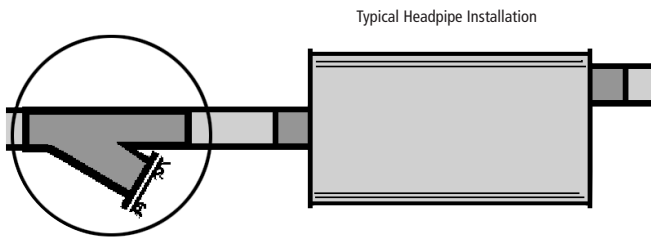

APPLICATION	DESCRIPTION
<b>RACE READIES TWIN PACKS - INCLUDES FREE TRACK TOOL</b>	
53001FLT	2-3/8" Slip-fit only - fits 5.0L Mustangs, and most 2-1/4" systems
53026FLT	Fits 2-1/2" 3-bolt headers* or into 2-1/2" exhaust pipes. Includes two 2-1/2" 3-hole flanges
53031FLT	Fits 3" 3-bolt headers* or into 3" exhaust pipes. Includes two 3" 3-hole flanges
53036FLT	Fits 3-1/2" 3-bolt headers* or into 3-1/2" exhaust pipes. Includes two 3-1/2" 3-hole flanges
<b>RACE READIES SINGLE PACK</b>	
53000FLT	2-3/8" Slip-fit only - fits 5.0L Mustangs, and most 2-1/4" systems
53025FLT	Fits 2-1/2" 3-bolt headers* or into 2-1/2" exhaust pipes. Includes two 2-1/2" 3-hole flanges
53030FLT	Fits 3" 3-bolt headers* or into 3" exhaust pipes, includes two 3" 3-hole flanges

\*Two 3-bolt header flanges included in kit.

EG HEADERS

FULL LENGTH HEADERS

BLOCK HUGGER HEADERS

RACE HEADERS

IMPORT HEADERS

GLASS PACK MUFFLERS

TURBO-STYLE MUFFLERS

IMPORT MUFFLERS

CATBACKS

H-PIPES & X-PIPES

TIPS

COMPONENTS & ACCESSORIES

MERCHANDISING

PHOTO GALLERY PART # INDEX

# THRUST TUBES, FLANGED TURNOUTS, REDUCERS/STREET HOOKUPS



## Afterburner™ Thrust Toobs

Afterburner Thrust Toobs used with open headers are designed to complete the system and squeeze out extra horsepower and torque. Designed to bolt behind any three-bolt header collector and are made from durable 16-gauge tubing.

- Fully-welded construction
- 16-gauge tubing



## Warlock™ Flanged Turnouts

Warlock flanged turnouts are designed to help direct exhaust flow away from under your vehicle. They also work well with the Warlock By-Pass mufflers when they are in the open configuration.



## Terminator™ Reducers/Street Hookups

Terminator fully-welded reducers/street hookups are designed to be used behind three-bolt design collectors and help make any header installation complete.

- Fully-welded construction
- Durable 16 gauge construction

PART NUMBER	INLET	SIZES	DESCRIPTION
<b>A) AFTERBURNER THRUST TOOBS - (HEADERS EXTENSIONS)</b>			
10511FLT	3-Bolt	3" inlet x 12" long	Package Contains One Pair
<b>B) WARLOCK FLANGED TURNOUTS</b>			
10410FLT	3-Bolt	2-1/2" inlet x 12" long	(Rotate 360°) Pair
10411FLT	3-Bolt	3" inlet x 12" long	(Rotate 360°) Pair
<b>C) TERMINATOR FULLY-WELDED REDUCERS/STREET HOOKUPS</b>			
10011FLT	3-Bolt	3" In x 2-1/8" Out	Package Contains One Pair
10012FLT	3-Bolt	2-1/2" In x 2" Out	Package Contains One Pair
10016FLT	3-Bolt	3-1/2" In x 2-1/2" Out	Package Contains One Pair



## Do-It-Yourself Components

FLOWTECH understands that when you purchase a set of headers, a muffler, or even an entire exhaust system, you want to know that you're getting everything you need to complete the installation. That's why we pride ourselves on our installation kits, which include all the gaskets, hardware, and fasteners necessary to hook up your headers, mufflers and/or tailpipes or side-mounts in minutes.

But what happens when you're doing a custom installation, or if you want to do a show-quality job with no compromise in quality, fit or finish?

The answer is a complete line of reducers, brackets, and emissions accessories, all precision-engineered by FLOWTECH. These installation accessories will turn your FLOWTECH system header installation into a work of art that looks as good as it sounds and performs.

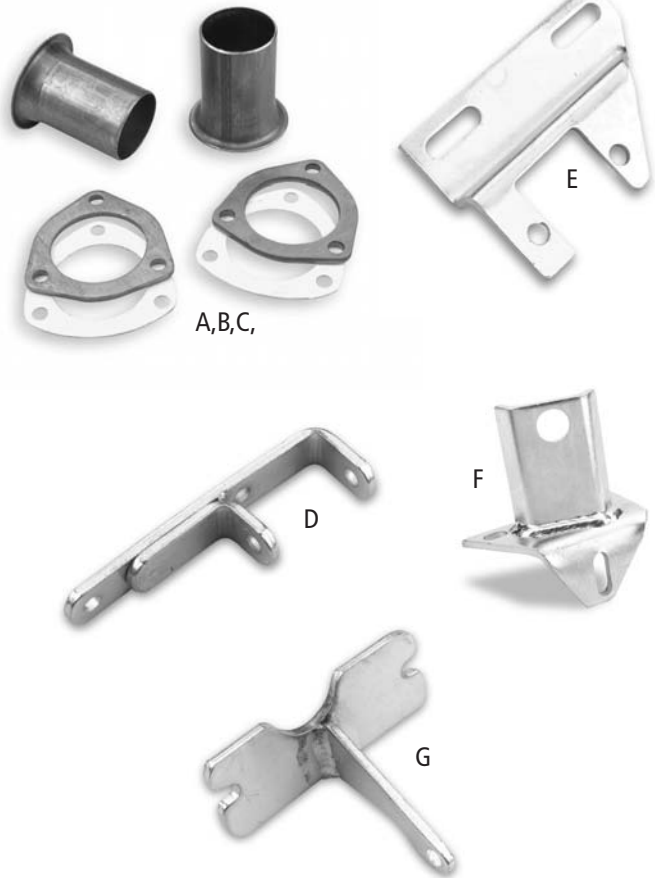

DESCRIPTION	PART #	REFERENCE
<b>DO-IT YOURSELF COMPONENTS</b>		
<b>REDUCERS</b>		
10-Pack (Prs) #10004 Sold in Boxes of 10 Pair Only	10002FLT	A
10-Pack (Prs) #10005 Sold in Boxes of 10 Pair Only	10003FLT	A
3-Bolt 3" x 2 1/2" (Pr) Self-Selling Display Package	10004FLT	A
3-Bolt 2 1/2" x 2 1/4" (Pr) Self-Selling Display Package	10005FLT	B
3-Bolt 3" x 2 1/8" (Pr) Self-Selling Display Package	10007FLT	C
<b>BRACKETS</b>		
Chevrolet Generator/Alternator Bracket - Display Carded	10031FLT	E
Chevrolet "F" Type Alternator Bracket - Display Carded	10033FLT	D
Ford Power Steering, Ram Drop Bracket - Display Carded	10041FLT	F
Chevrolet Air Conditioning Bracket - Display Carded	10042FLT	G
<b>EMISSIONS ACCESSORIES</b>		
3-Bolt 2 1/2" Reducer with O <sup>2</sup> Sensor Fitting	10105FLT	-
3-Bolt 3" Reducer with O <sup>2</sup> Sensor Fitting	10110FLT	-
Weld-In O <sup>2</sup> Sensor Fitting	10120FLT	-

**18" X 7" FLOWTECH LOGO METAL SIGN - P/N 10000FLT**

**90" X 30" FLOWTECH LOGO BANNER - P/N 36-373**

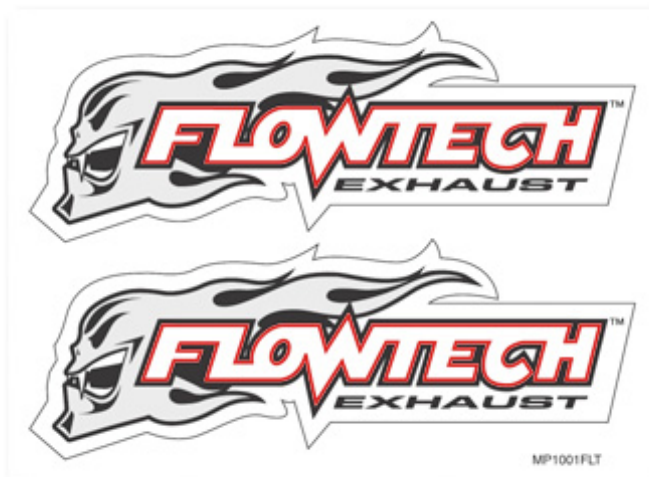
**4.5" X 3.25" FLOWTECH DECAL SHEETS - P/N MP1001FLT**



Chevy 265-400 Universal Street Rod  
**11030FLT**

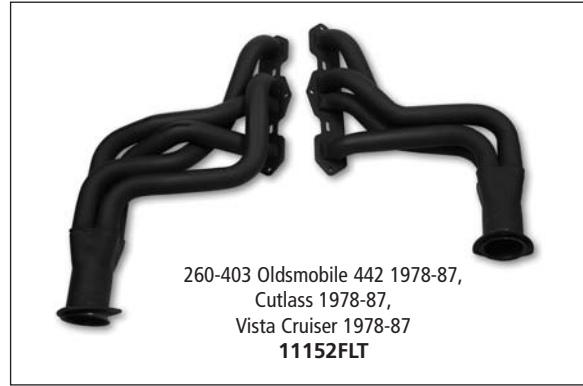

260-403 Oldsmobile 442 1978-87,  
Cutlass 1978-87,  
Vista Cruiser 1978-87  
**11152FLT**



351-400M Ford 1/2, 3/4, 1 TON PU  
1978-79, Bronco 1978-79  
**12508FLT**

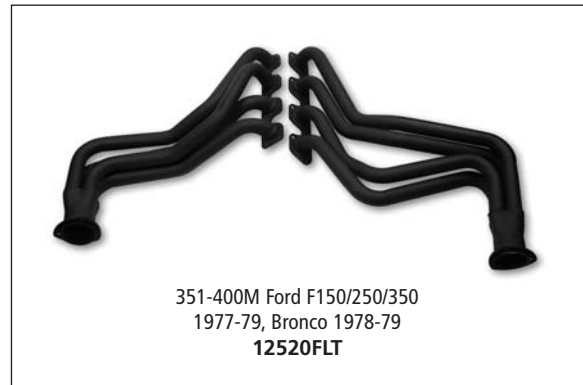

351-400M Ford F150/250/350  
1977-79, Bronco 1978-79  
**12520FLT**



429-460 Ford F250/350 1974-79  
**12564FLT**

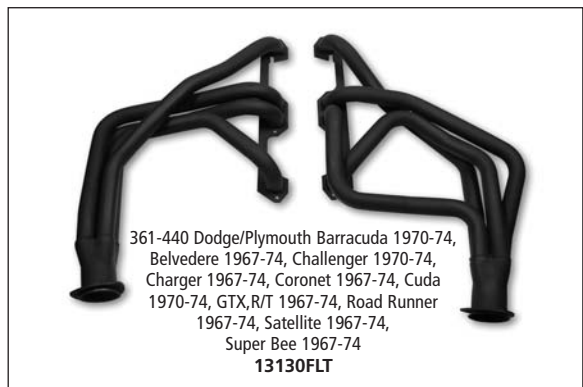

361-440 Dodge/Plymouth Barracuda 1970-74,  
Belvedere 1967-74, Challenger 1970-74,  
Charger 1967-74, Coronet 1967-74, Cuda  
1970-74, GTX, R/T 1967-74, Road Runner  
1967-74, Satellite 1967-74,  
Super Bee 1967-74  
**13130FLT**

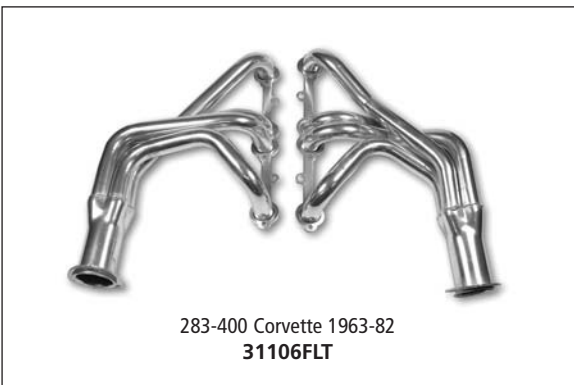

283-400 Corvette 1963-82  
**31106FLT**

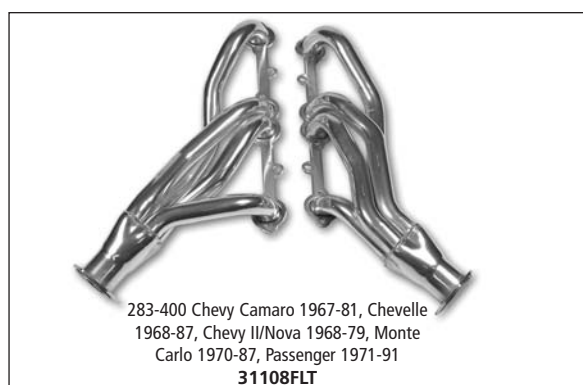

283-400 Chevy Camaro 1967-81, Chevelle  
1968-87, Chevy II/Nova 1968-79, Monte  
Carlo 1970-87, Passenger 1971-91  
**31108FLT**

- EO HEADERS
- FULL LENGTH HEADERS
- BLOCK HUGGER HEADERS
- RACE HEADERS
- IMPORT HEADERS
- GLASS PACK MUFFLERS
- TURBO-STYLE MUFFLERS
- IMPORT MUFFLERS
- CATBACKS
- H-PIPES & X-PIPES
- TIPS
- COMPONENTS & ACCESSORIES
- MERCHANDISING
- PHOTO GALLERY PART # INDEX

EO HEADERS

FULL LENGTH HEADERS

BLOCK HUGGER HEADERS

RACE HEADERS

IMPORT HEADERS

GLASS PACK MUFFLERS

TURBO-STYLE MUFFLERS

IMPORT MUFFLERS

CATBACKS

H-PIPES & X-PIPES

TIPS

COMPONENTS & ACCESSORIES

MERCHANDISING

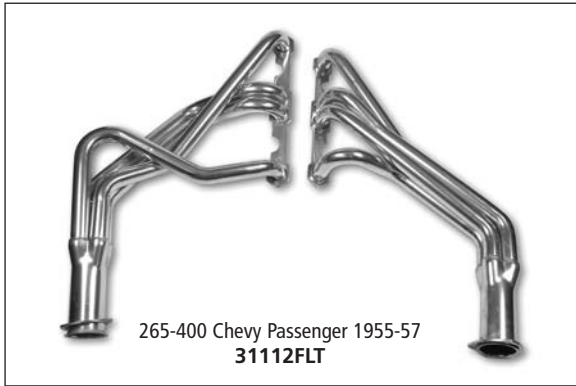

265-400 Chevy Passenger 1955-57  
**31112FLT**

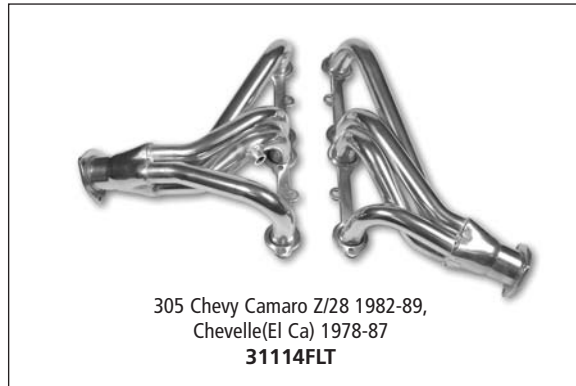

305 Chevy Camaro Z/28 1982-89,  
Chevelle(El Ca) 1978-87  
**31114FLT**

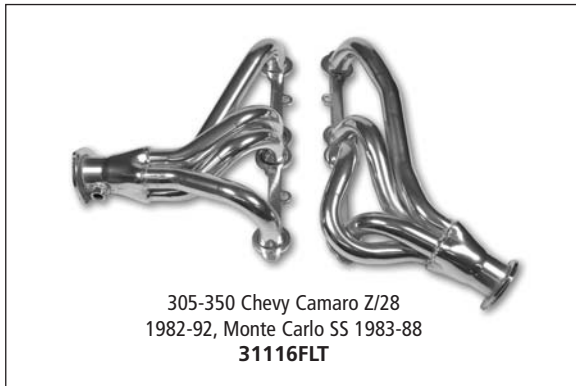

305-350 Chevy Camaro Z/28  
1982-92, Monte Carlo SS 1983-88  
**31116FLT**

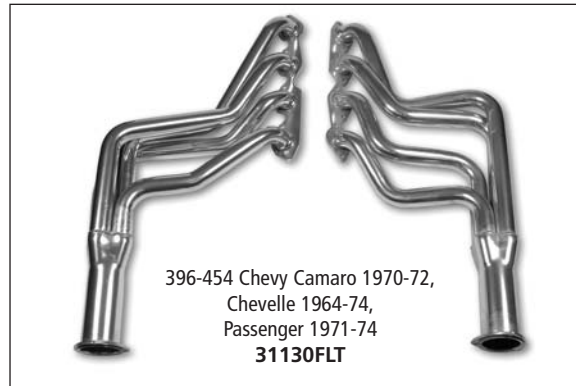

396-454 Chevy Camaro 1970-72,  
Chevelle 1964-74,  
Passenger 1971-74  
**31130FLT**

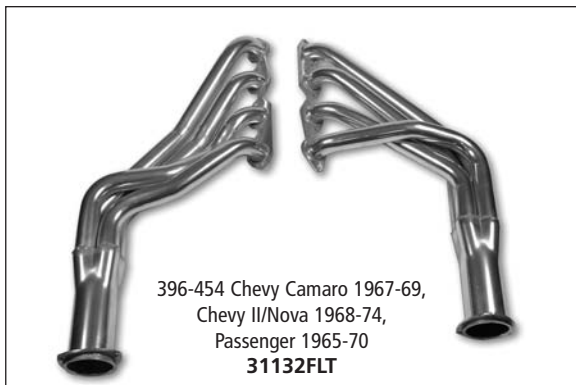

396-454 Chevy Camaro 1967-69,  
Chevy II/Nova 1968-74,  
Passenger 1965-70  
**31132FLT**

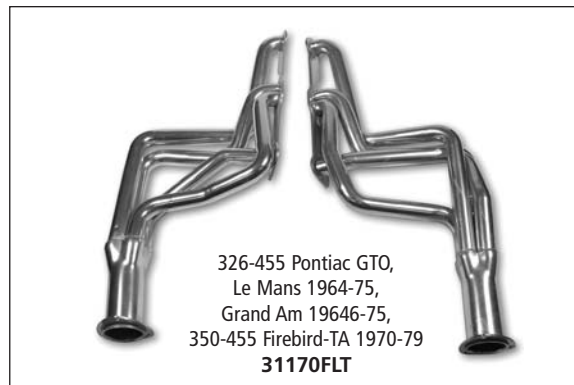

326-455 Pontiac GTO,  
Le Mans 1964-75,  
Grand Am 19646-75,  
350-455 Firebird-TA 1970-79  
**31170FLT**



283-400 Chevy/GMC  
S10/15 PU Eng Swap 1982-93, S10 Blazer Swap 1982-93  
**31502FLT**

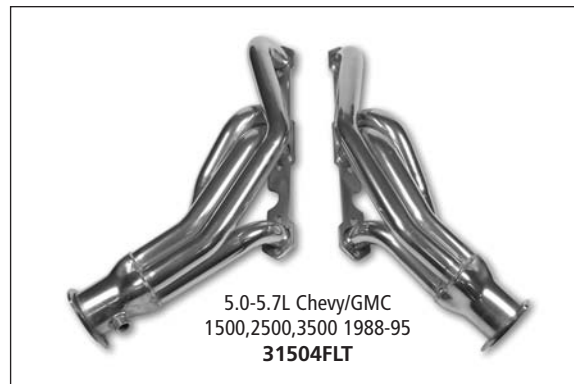

5.0-5.7L Chevy/GMC  
1500,2500,3500 1988-95  
**31504FLT**

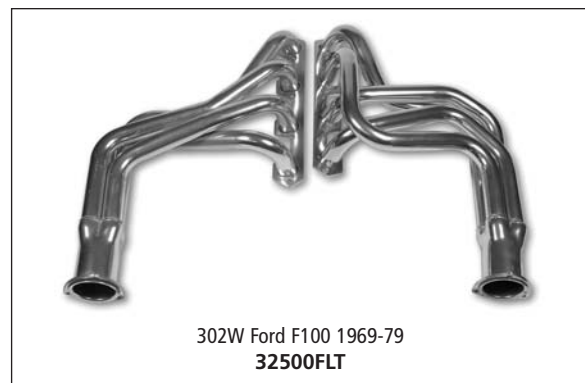
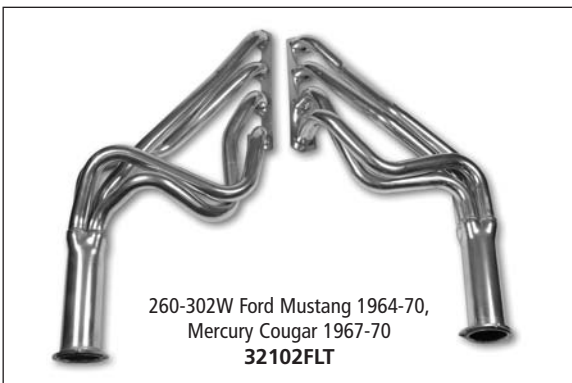
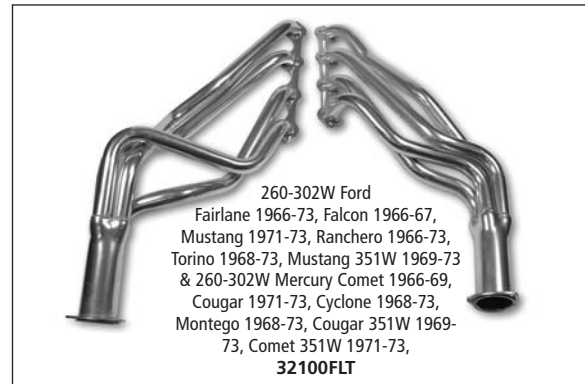
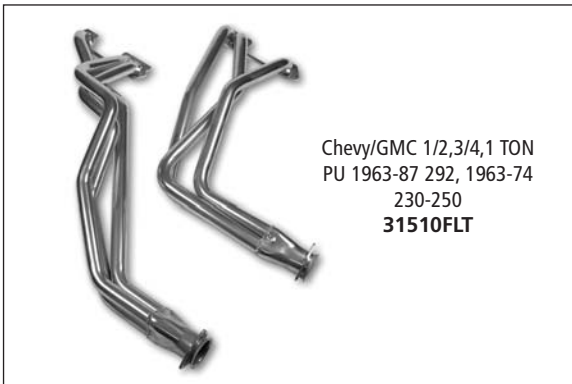
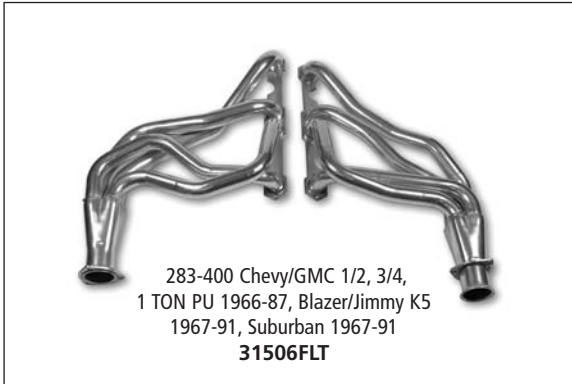

- EO HEADERS
- FULL LENGTH HEADERS
- BLOCK HUGGER HEADERS
- RACE HEADERS
- IMPORT HEADERS
- GLASS BACK MUFFLERS
- TURBO-STYLE MUFFLERS
- IMPORT MUFFLERS
- CATBACKS
- H-PIPES & X-PIPES
- TIPS
- COMPONENTS & ACCESSORIES
- MERCHANDISING

EO HEADERS

FULL LENGTH HEADERS

BLOCK HUGGER HEADERS

RACE HEADERS

IMPORT HEADERS

GLASS PACK MUFFLERS

TURBO-STYLE MUFFLERS

IMPORT MUFFLERS

CATBACKS

H-PIPES & X-PIPES

TIPS

COMPONENTS & ACCESSORIES

MERCHANDISING

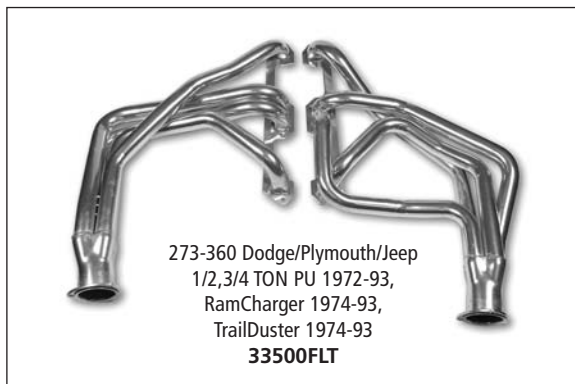
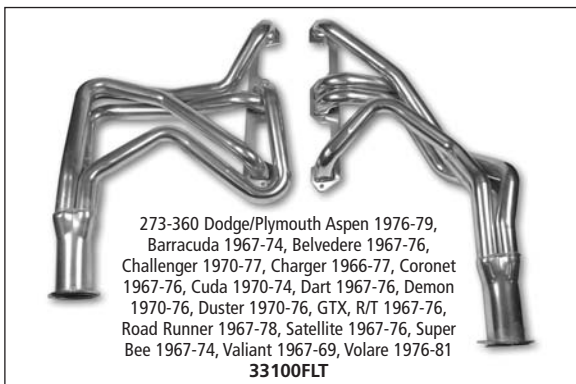
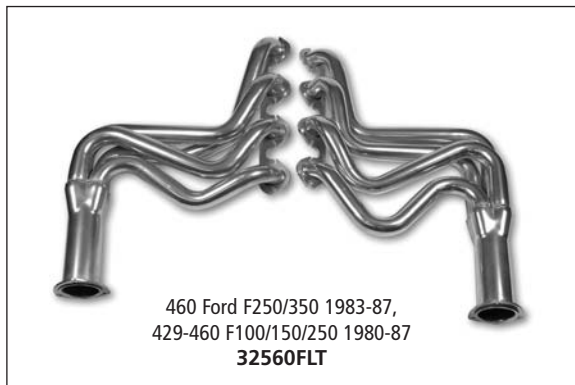
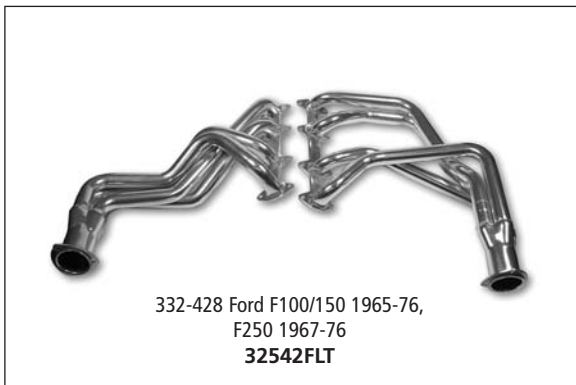
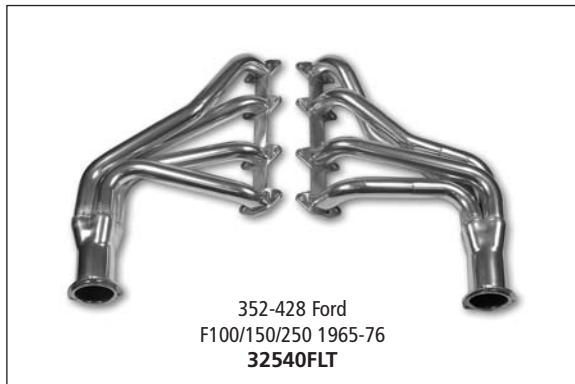
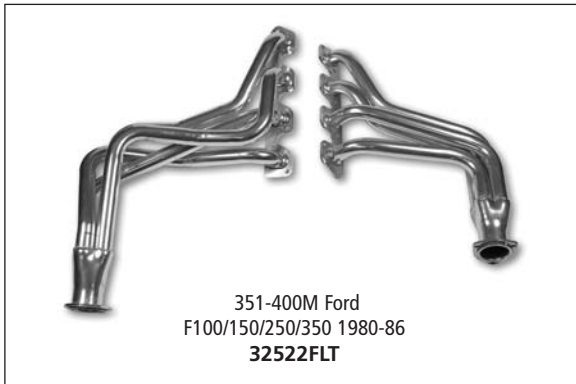
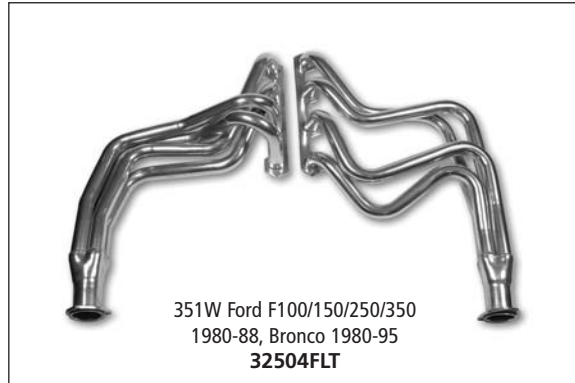
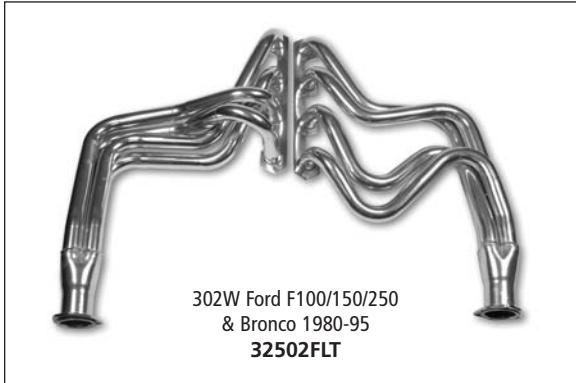

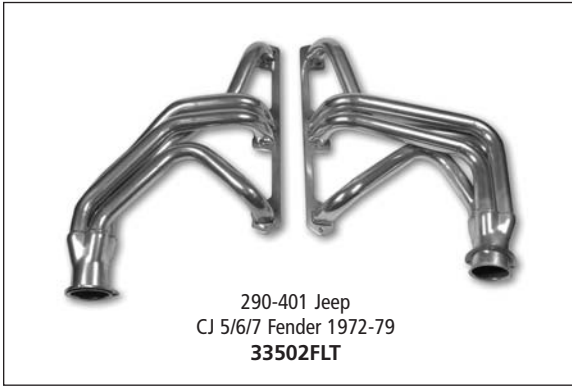

290-401 Jeep  
CJ 5/6/7 Fender 1972-79  
**33502FLT**

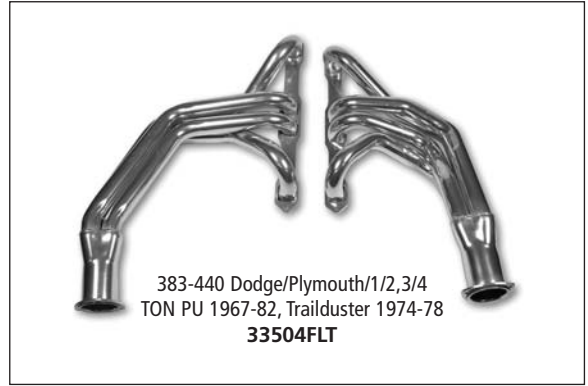

383-440 Dodge/Plymouth/1/2,3/4  
TON PU 1967-82, Trailduster 1974-78  
**33504FLT**

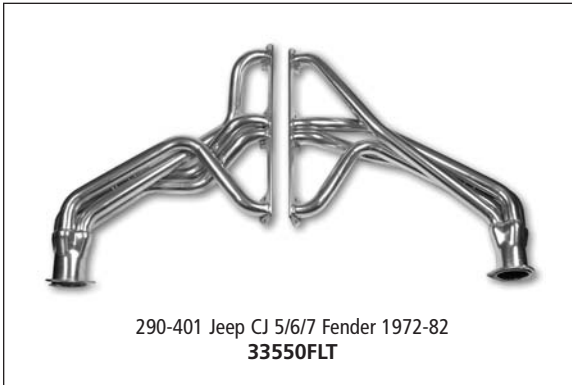

290-401 Jeep CJ 5/6/7 Fender 1972-82  
**33550FLT**



289-351W Ford IMCA Race Style  
**48200FLT**

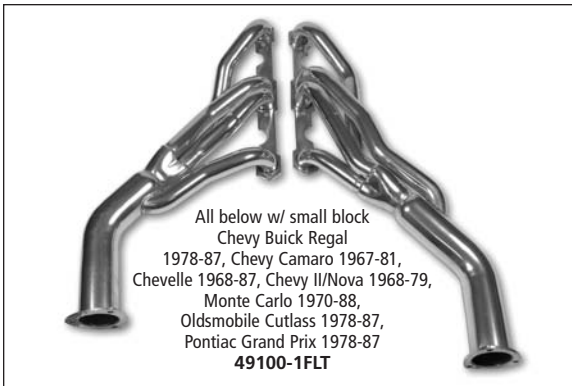

All below w/ small block  
Chevy Buick Regal  
1978-87, Chevy Camaro 1967-81,  
Chevelle 1968-87, Chevy II/Nova 1968-79,  
Monte Carlo 1970-88,  
Oldsmobile Cutlass 1978-87,  
Pontiac Grand Prix 1978-87  
**49100-1FLT**

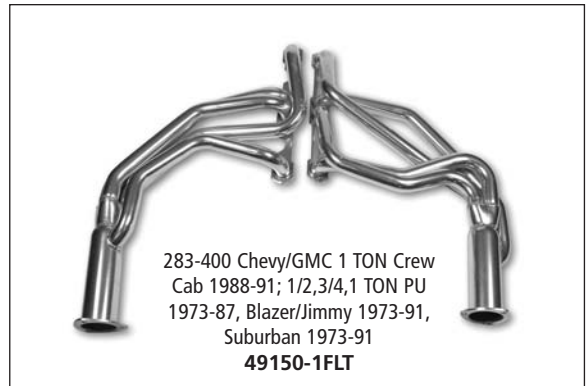

283-400 Chevy/GMC 1 TON Crew  
Cab 1988-91; 1/2,3/4,1 TON PU  
1973-87, Blazer/Jimmy 1973-91,  
Suburban 1973-91  
**49150-1FLT**

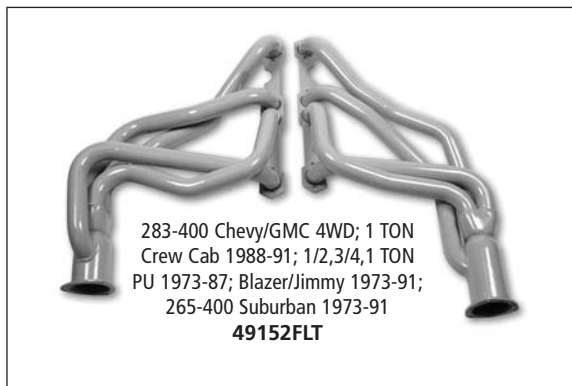

283-400 Chevy/GMC 4WD; 1 TON  
Crew Cab 1988-91; 1/2,3/4,1 TON  
PU 1973-87; Blazer/Jimmy 1973-91;  
265-400 Suburban 1973-91  
**49152FLT**

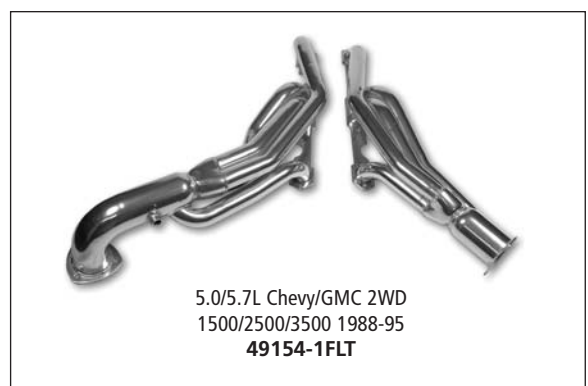

5.0/5.7L Chevy/GMC 2WD  
1500/2500/3500 1988-95  
**49154-1FLT**

- EO HEADERS
- FULL LENGTH HEADERS
- BLOCK HUGGER HEADERS
- RACE HEADERS
- IMPORT HEADERS
- GLASS PACK MUFFLERS
- TURBO-STYLE MUFFLERS
- IMPORT MUFFLERS
- CATBACKS
- H-PIPES & X-PIPES
- TIPS
- COMPONENTS & ACCESSORIES
- MERCHANDISING

EO HEADERS

FULL LENGTH HEADERS

BLOCK HUGGER HEADERS

RACE HEADERS

IMPORT HEADERS

GLASS PACK MUFFLERS

TURBO-STYLE MUFFLERS

IMPORT MUFFLERS

CATBACKS

H-PIPES & X-PIPES

TIPS

COMPONENTS & ACCESSORIES

MERCHANDISING

PHOTO GALLERY & PART # INDEX

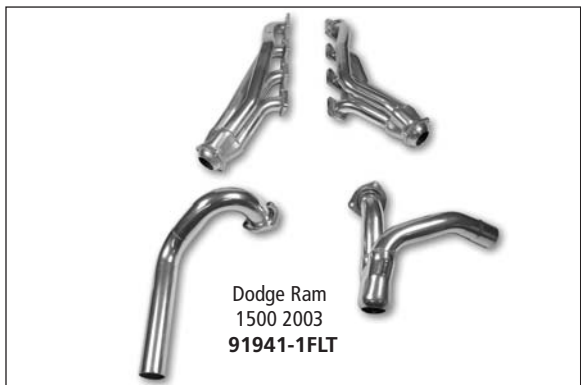
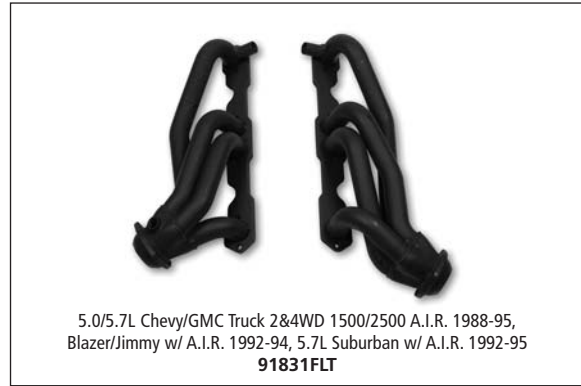
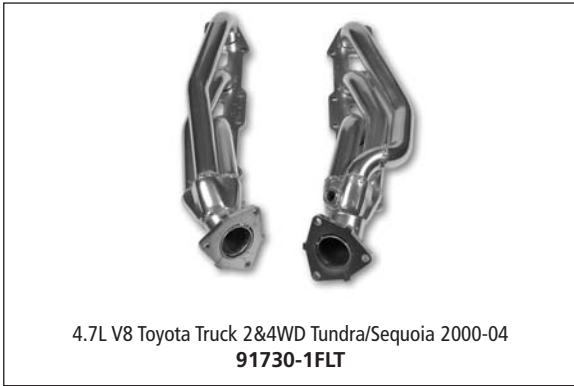
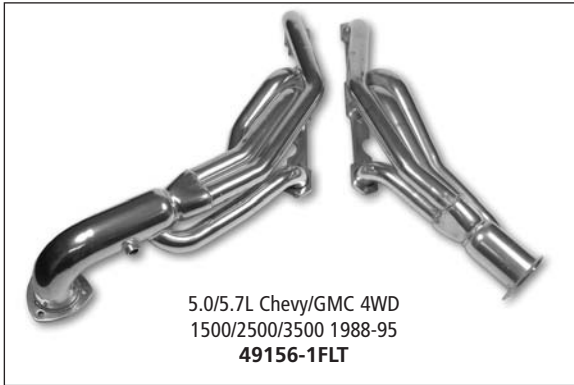





# PART NUMBER TO PAGE INDEX

Part #	Page	Part #	Page	Part #	Page
36-373	40	12106FLT	6,11	32110FLT	6,11
MP1001FLT	40	12107FLT	6,11	32112FLT	6,11
10000FLT	40	12110FLT	6,11	32118FLT	6
10002FLT	39	12112FLT	6,11	32500FLT	8
10003FLT	39	12114-1FLT	6	32502FLT	8
10004FLT	39	12114FLT	6	32504FLT	9
10005FLT	39	12114YFLT	6,32	32506FLT	8
10007FLT	39	12115-1FLT	6	32508FLT	9
10010FLT	13	12115FLT	6	32520FLT	9
10011FLT	38	12115YFLT	6,32	32522FLT	8
10012FLT	38	12118FLT	6	32540FLT	8
10016FLT	38	12500FLT	8	32542FLT	9
10024FLT	35	12502FLT	8	32560FLT	8
10025FLT	35	12504FLT	9	32564FLT	8
10026FLT	35	12506FLT	8	33100FLT	5
10031FLT	39	12508FLT	9	33130FLT	5
10033FLT	39	12520FLT	9	33500FLT	8
10041FLT	39	12522FLT	8	33502FLT	9
10042FLT	39	12540FLT	8	33504FLT	9
10105FLT	39	12542FLT	9	33550FLT	9
10110FLT	39	12560FLT	8	42600FLT	23
10120FLT	39	12564FLT	8	42601FLT	23
10410FLT	38	13100FLT	5	42604FLT	25
10411FLT	38	13130FLT	5	42605FLT	25
10511FLT	38	13500FLT	8	48100FLT	14
11000FLT	13	13502FLT	9	48102FLT	14
11030FLT	13	13504FLT	9	48200FLT	14
11100FLT	5	13550FLT	9	49100-1FLT	10
11102FLT	5	16102-1FLT	12	49100FLT	10
11102YFLT	9	16102FLT	12	49150-1FLT	10
11104FLT	7	22609FLT	8	49150FLT	10
11106FLT	5	31000FLT	13	49152-1FLT	10
11108FLT	5,12	31030FLT	13	49152FLT	10
11110FLT	5	31100FLT	5	49154-1FLT	10
11112FLT	5	31102FLT	5	49154YFLT	9
11114FLT	5	31102FLT	5	49154FLT	10
11116FLT	5	31104FLT	7	49156-1FLT	10
11130FLT	5	31106FLT	5	49156YFLT	9
11132FLT	5	31108FLT	5	49156FLT	10
11133-1FLT	5	31110FLT	5	50050FLT	21
11133Y-1FLT	5,9	31112FLT	5	50051FLT	21
11133FLT	5	31114FLT	5	50052FLT	21
11133YFLT	5,9	31116FLT	5	50054FLT	21
11134-1FLT	5	31130FLT	5	50121FLT	22,30
11134FLT	5	31132FLT	5	50122FLT	22
11150FLT	7	31150FLT	7	50130FLT	22
11152FLT	7	31152FLT	7	50151FLT	22,23
11154FLT	7	31154FLT	7	50152FLT	22,23
11170FLT	7	31170FLT	7	50162FLT	22
11500FLT	8	31500FLT	8	50170FLT	22
11502FLT	8	31502FLT	8	50225FLT	18
11504FLT	8	31504FLT	8	50230FLT	18
11504YFLT	9	31506FLT	8	50231FLT	18
11506FLT	8	31508FLT	8	50232FLT	18
11508FLT	8	31510FLT	8	50250FLT	17
11510FLT	8	31530FLT	8	50251FLT	17
11530FLT	8	32000FLT	13	50252FLT	17
12000FLT	13	32100FLT	6	50253FLT	22
12100FLT	6	32102FLT	6	50320FLT	20
12102FLT	6	32104FLT	6,11	50321FLT	20
12104FLT	6	32107FLT	6	50322FLT	20
12104FLT	11	32107FLT	11	50330FLT	20

- EO HEADERS
- FULL LENGTH HEADERS
- BLOCK HUGGER HEADERS
- RACE HEADERS
- IMPORT HEADERS
- GLASS BACK MUFFLERS
- TURBO-STYLE MUFFLERS
- IMPORT MUFFLERS
- CATBACKS
- H-PIPES & X-PIPES
- TIPS
- COMPONENTS & ACCESSORIES
- MERCHANDISING

## PART NUMBER TO PAGE INDEX



Part #	Page	Part #	Page	Part #	Page
50351FLT	.20	80168FLT	.16	91941-1FLT	.3
50352FLT	.20	80169FLT	.16	91941FLT	.3
50362FLT	.20	80504FLT	.15	91944-1FLT	.3
50363FLT	.20	80506FLT	.15	91944FLT	.3
50370FLT	.20	80522FLT	.15	91945-1FLT	.3
50371FLT	.20	80524FLT	.15	91945FLT	.3
50522FLT	.19	80528FLT	.15	91946-1FLT	.3
50551FLT	.19	80534FLT	.15	91946FLT	.3
50552FLT	.19	80540FLT	.15	91947-1FLT	.3
50560FLT	.19	80566FLT	.16	91947FLT	.3
51525FLT	.30	80567FLT	.16	91948-1FLT	.3
51555FLT	.30	80568FLT	.16	91948FLT	.3
52525FLT	.30	81000FLT	.28	99150FLT	.35
53000FLT	.37	81002FLT	.28	99150AFLT	.35
53001FLT	.37	81004FLT	.28	99153FLT	.35
53025FLT	.37	81020FLT	.28	99160FLT	.36
53026FLT	.37	81022FLT	.28	99161FLT	.36
53030FLT	.37	81024FLT	.28	99162FLT	.36
53031FLT	.37	81026FLT	.28	99253FLT	.35
53036FLT	.37	81028FLT	.28	99253RFLT	.35
53604FLT	.31	81030FLT	.28	99260FLT	.36
53605FLT	.31	81034FLT	.28	99261FLT	.36
53606FLT	.31	81035FLT	.28	99262FLT	.36
53607FLT	.31	81404FLT	.29	99263FLT	.36
53608FLT	.31	81426FLT	.29	99264FLT	.36
53609FLT	.31	81430FLT	.29	99360FLT	.36
53620FLT	.33	81432FLT	.29	99361FLT	.36
53621FLT	.33	81434FLT	.29	99460FLT	.36
53622FLT	.33	81435FLT	.29	99560FLT	.36
53623FLT	.33	81462FLT	.29		
53624FLT	.32	81464FLT	.29		
53625FLT	.32	82490FLT	.28		
53626FLT	.32	85045FLT	.34		
53627FLT	.32	85145FLT	.34		
53628FLT	.32	91627-1FLT	.3		
59324FLT	.34	91627FLT	.3		
59325FLT	.34	91628-1FLT	.3		
59904FLT	.34	91628FLT	.3		
59905FLT	.34	91668-1FLT	.3		
62100FLT	.26	91668FLT	.3		
62106FLT	.26	91669-1FLT	.3		
62110FLT	.26	91669FLT	.3		
62151FLT	.27	91670-1FLT	.3		
62152FLT	.27	91670FLT	.3		
62400FLT	.26	91730-1FLT	.3		
62451FLT	.27	91730FLT	.3		
62452FLT	.27	91830-1FLT	.3		
62800FLT	.26	91830-1FLT	.3		
62851FLT	.27	91830FLT	.3		
62852FLT	.27	91831FLT	.3		
80004FLT	.15	91832-1FLT	.3		
80006FLT	.15	91832FLT	.3		
80024FLT	.15	91834-1FLT	.3		
80026FLT	.15	91834FLT	.3		
80032FLT	.15	91835-1FLT	.3		
80034FLT	.15	91835FLT	.3		
80040FLT	.15	91836-1FLT	.3		
80065FLT	.16	91836FLT	.3		
80066FLT	.16	91837-1FLT	.3		
80068FLT	.16	91837FLT	.3		
80102FLT	.15	91940-1FLT	.3		
80124FLT	.15	91940FLT	.3		

