

START HERE!

READ ME FIRST

Don't be a hero and muscle through this installation without reading these fitting instructions first! Improper installation of this gear may void certain aspects of your warranty.

Before you begin, take a moment and open all your Front Runner rack kit boxes and gather the assembly instructions for the various components.

A complete kit will contain:

1. A Front Runner Mounting System specific to your vehicle
2. A Front Runner Rack Tray or Load Bar Slats

This document will guide you through the assembly of the mounting system and assist you in fitting the roof rack tray or load bars to your specific vehicle.

Please refer to the next page for a list of all the components, quantities and tools required.

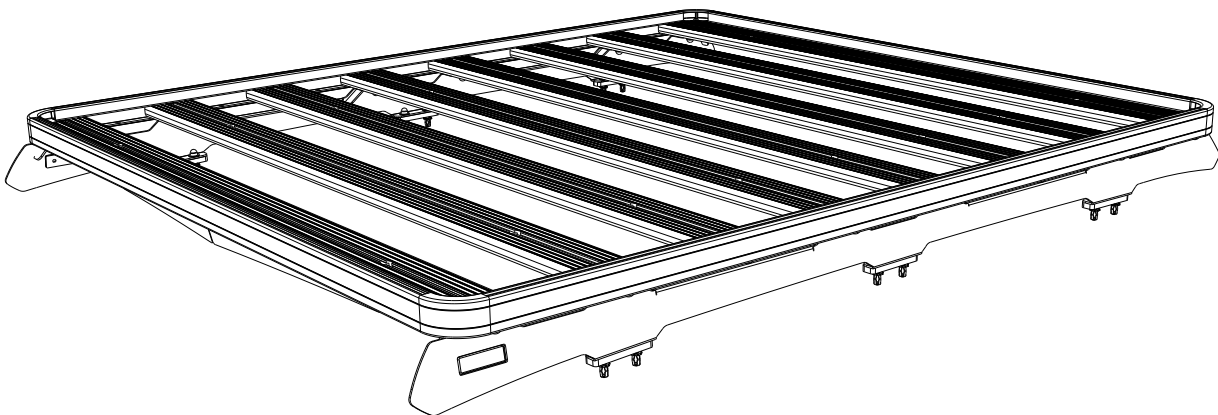

IMPORTANT WARNING!

IT IS CRITICAL THAT ALL FRONT RUNNER PRODUCTS BE PROPERLY AND SECURELY ASSEMBLED AND ATTACHED TO YOUR VEHICLE. IMPROPER ATTACHMENT COULD RESULT IN AN AUTOMOBILE ACCIDENT, AND COULD CAUSE SERIOUS BODILY INJURY OR DEATH. YOU ARE RESPONSIBLE FOR ASSEMBLING AND SECURING ALL FRONT RUNNER PRODUCTS TO YOUR VEHICLE, CHECKING THE ATTACHMENTS PRIOR TO USE, AND PERIODICALLY INSPECTING THE PRODUCTS FOR ADJUSTMENT, WEAR AND DAMAGE. THEREFORE, YOU MUST READ AND UNDERSTAND ALL OF THE INSTRUCTIONS AND PRECAUTIONS SUPPLIED WITH YOUR FRONT RUNNER PRODUCT PRIOR TO INSTALLATION OR USE. IF YOU DO NOT UNDERSTAND ALL OF THE INSTRUCTIONS AND CAUTIONS, OR IF YOU HAVE NO MECHANICAL EXPERIENCE AND ARE NOT THOROUGHLY FAMILIAR WITH THE INSTALLATION PROCEDURES, YOU SHOULD HAVE THE PRODUCT INSTALLED BY A PROFESSIONAL INSTALLER OR OTHER QUALIFIED PERSONNEL.

NOTE: Front Runner will not be responsible for any damage caused by the failure to install the product according to these instructions.

Please call us if you have any questions about the installation of this product.

1

GET ORGANIZED

IN THE BOX

1	2 X	Foot Rail 1LH + 1RH
2	6 X	Spacer
3	14 X	M6 Jack Nut
4	12 X	M8 Nut Cap
5	12 X	M8 Nyloc Nut
6	12 X	M8 x 16 x 1.6SS Flat Washer
7	12 X	M8 x 20 Hex Bolt
8	12 X	M6 Nut Cap
9	12 X	M6 x 40 Hex Bolt
10	12 X	M6 SS Spring Washer
11	12 X	M6 x 19 x 1 SS Flat Washer
12	2 X	M6 x 30 Button Head Bolt
13	1 X	Installer Wrench

TOOLS NEEDED

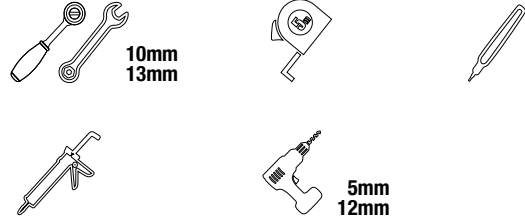
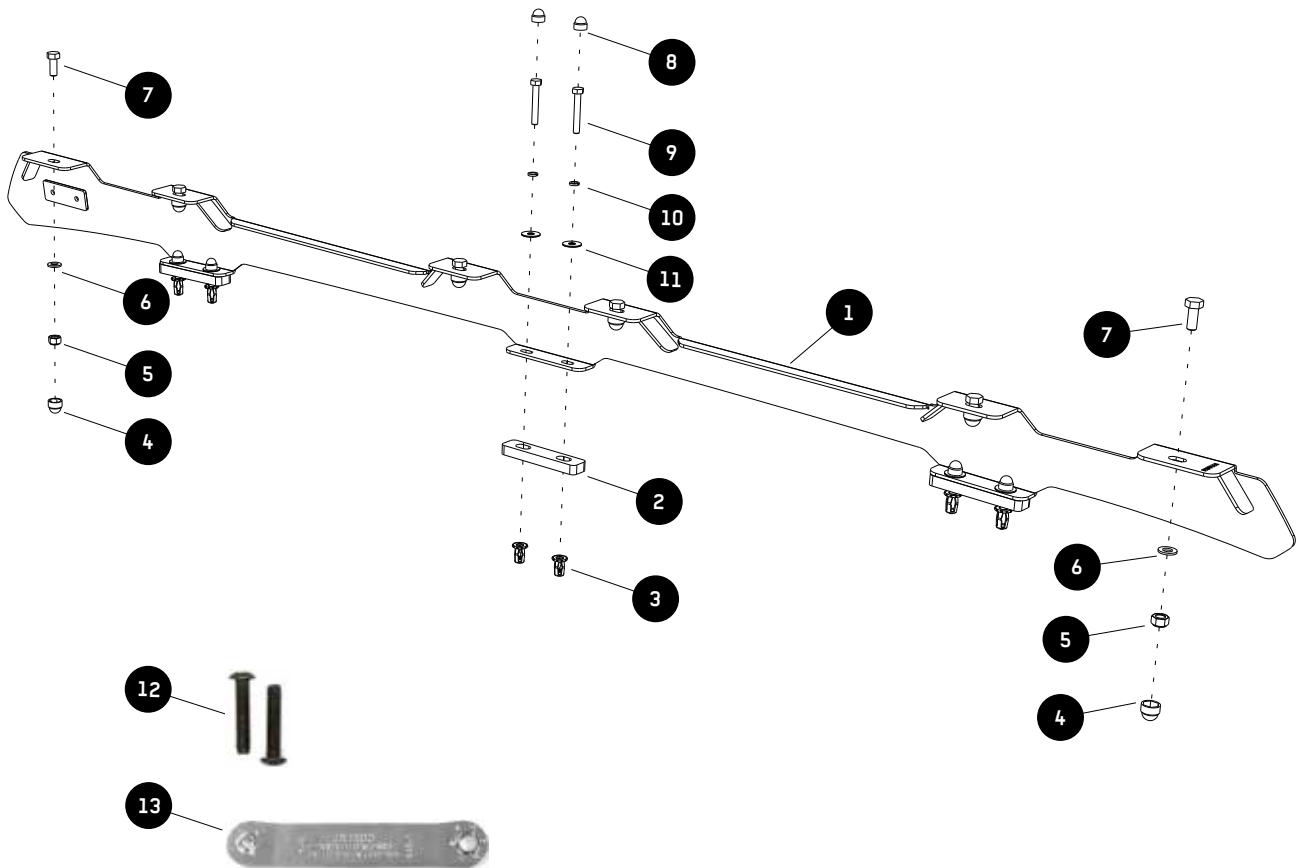

FIGURE 1.1



2.1



Measure 200mm forward from the centre of the rivet in the ditch moulding shown in Step 2.1 and make a mark in the roof ditch. This will be the rear hole for the Foot Rail.

2.2

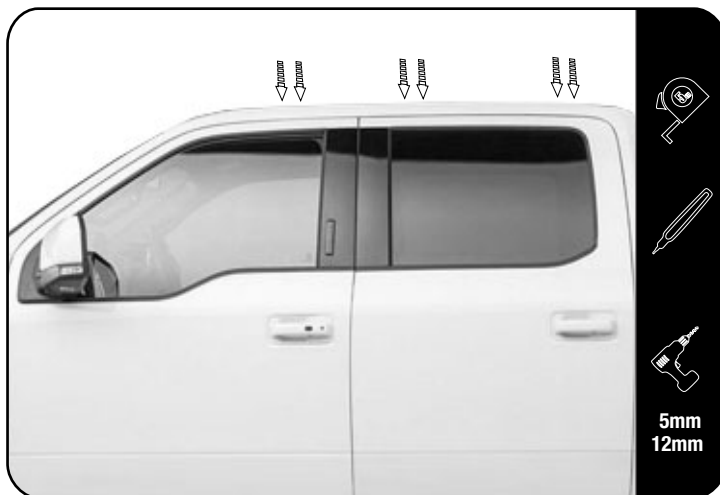

Position the Foot Rail in the ditch. Align the rear mount hole in the Foot Rail with the rear mark you made earlier in Step 2.1 and mark the remaining five holes.

Remove the Foot Rail from the vehicle.

Drill a 5mm Pilot hole in the centre of the markings. Open the holes using a 12mm Drill.

2.3

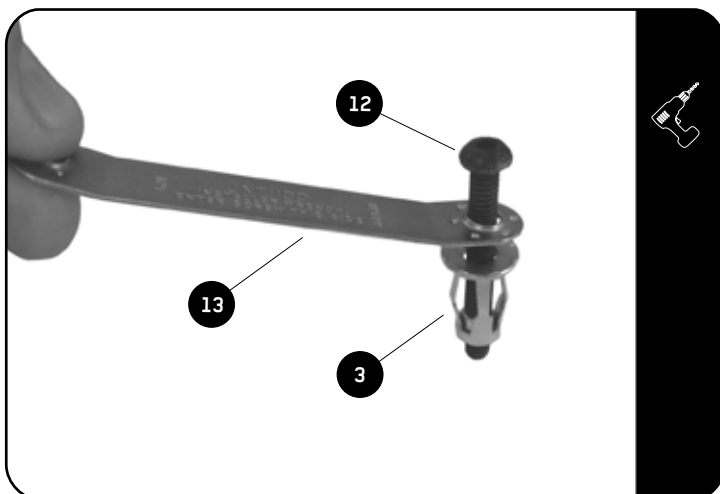

Insert the M6 Button Head Bolt (Item 12) into the one side of the Installer Wrench (Item 13). Loosely fit a Jack Nut (Item 3) to the Button Head Bolt as shown.

Using the Installer Wrench and a M6 x 30 Button Head Bolt, insert the M6 Jack Nuts into all 12 holes.

Place the assembly into a hole drilled in Step 2.2. Using a Battery Powered Screw Driver and a 4mm Allen Key Bit, set the Jack Nut into the hole while holding onto the handle of the Installer Wrench.



Make sure that the Jack Nut has pulled up all the way to the inside skin of the roof panel.

2**FIT AND SECURE**

2.4

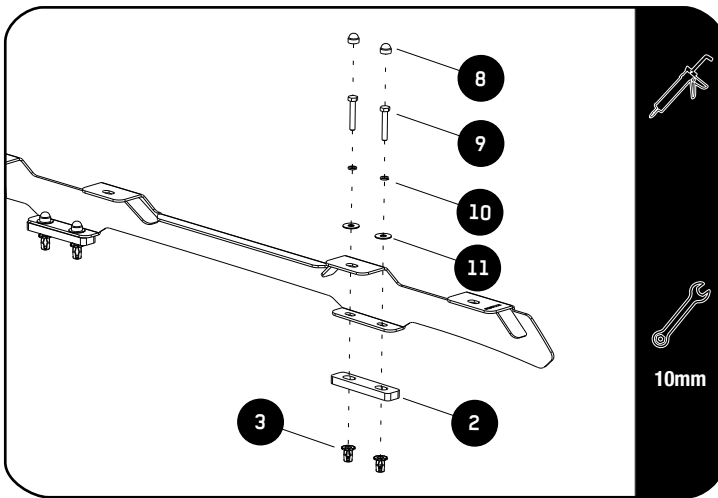

Place a bead of silicon around each of the Jack Nut openings inserted earlier in Step 2.3.

To fit the Foot Rails (Item 1LH & 1RH), place the Spacers (Item 2) over the Jack Nuts inserted in Step 2.3, followed by the Foot Rail (Item 1).

Secure the Foot Rails using the M6 x 40 Hex Bolts with silicon on the threads, M6 SS Spring Washers and M6 x 19 x 1SS Flat Washers (Items 9, 10 & 11).

Do this on both left and right side of the vehicle.

Finish of by placing M6 Nut Caps (Item 8) on the M6 Bolt heads.

3**FIT AND SECURE**

3.1

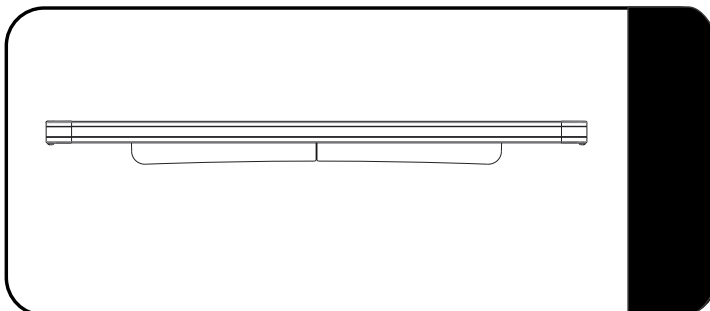

Make sure that the wind deflector is installed before you proceed to the next step.

Refer to Rack Fitment Guide.

3.2

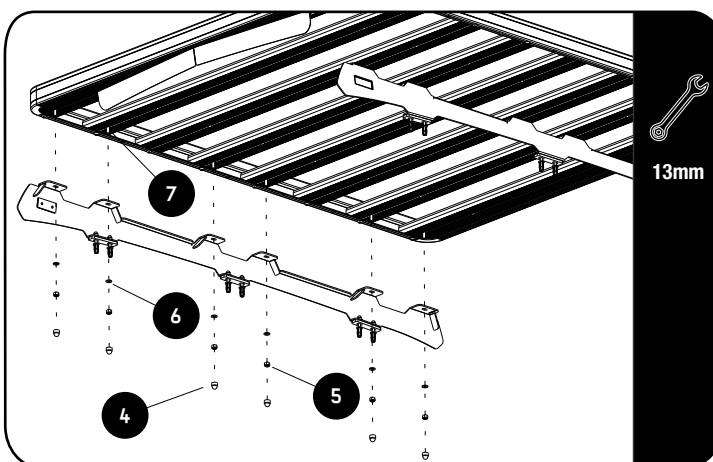

Fit your Roof Rack to the Foot Rails using M8 x 20 Hex Bolts, M8 x 16 x 1.6SS Flat Washers and M8 Nyloc Nuts (Items 5, 6 & 7).

3.3

Center the rack and tighten fully. Use M8 Nut Caps (Item 4) to finish off the nuts.



3

COMPLETION

3.1



Congratulations! You did it. Take a step back and admire your work!

4

INSTALL OTHER VEHICLE AND RACK ACCESSORIES

Now's the time to visit your favorite Front Runner Dealer in person or online.

IMPORTANT!

Front Runner rack kits often have a higher load rating than the vehicles they are mounted to. Please refer to your specific vehicle manufacturer for a recommended roof load rating. Front Runner cannot be responsible for improper loading beyond the vehicle manufacturer's stated load capacity.