



FRONT RUNNER

**LAND CRUISER 78
TALL SLIMLINE II RACK
(1425MM X 2772MM)**

KRRTL25L



INSTALL TIME: 1 Hour

START HERE

READ ME FIRST

Thank you for purchasing a Front Runner Slimline II Rack.

This Roof Rack consists of a kit that contains:

1. A Slimline II Tray
2. A mounting system specific to your vehicle

Before you start, take a moment and open all your boxes and gather the assembly instructions for the various components.

This document will guide you through the assembly of the various mounting system components and assist you in fitting the Slimline II Tray to your specific vehicle.

IMPORTANT WARNING!

IT IS CRITICAL THAT ALL FRONT RUNNER PRODUCTS BE PROPERLY AND SECURELY ASSEMBLED AND ATTACHED TO YOUR VEHICLE. IMPROPER ATTACHMENT COULD RESULT IN AN AUTOMOBILE ACCIDENT, AND COULD CAUSE SERIOUS BODILY INJURY OR DEATH TO YOU OR TO OTHERS. YOU ARE RESPONSIBLE FOR ASSEMBLING AND SECURING ALL FRONT RUNNER PRODUCTS TO YOUR VEHICLE, CHECKING THE ATTACHMENTS PRIOR TO USE, AND PERIODICALLY INSPECTING THE PRODUCTS FOR ADJUSTMENT, WEAR, AND DAMAGE. THEREFORE, YOU MUST READ AND UNDERSTAND ALL OF THE INSTRUCTIONS AND CAUTIONS SUPPLIED WITH YOUR FRONT RUNNER PRODUCT PRIOR TO INSTALLATION OR USE. IF YOU DO NOT UNDERSTAND ALL OF THE INSTRUCTIONS AND CAUTIONS, OR IF YOU HAVE NO MECHANICAL EXPERIENCE AND ARE NOT THOROUGHLY FAMILIAR WITH THE INSTALLATION PROCEDURES, YOU SHOULD HAVE THE PRODUCT INSTALLED BY A PROFESSIONAL INSTALLER OR OTHER QUALIFIED PERSONNEL.

1

ASSEMBLE YOUR SLIMLINE II RACK

REFER TO SLIMLINE II TRAY UNIVERSAL ASSEMBLY INSTRUCTION (DOCUMENT RRSTUNI)

2

FIT THE LEGS

REFER TO LEG ASSEMBLY INSTRUCTION (DOCUMENT LASSIUNI)

- (A) With your Rack in the upside down position (Product sticker should be upside down), fit the Legs to your Slimline II Tray as illustrated below.

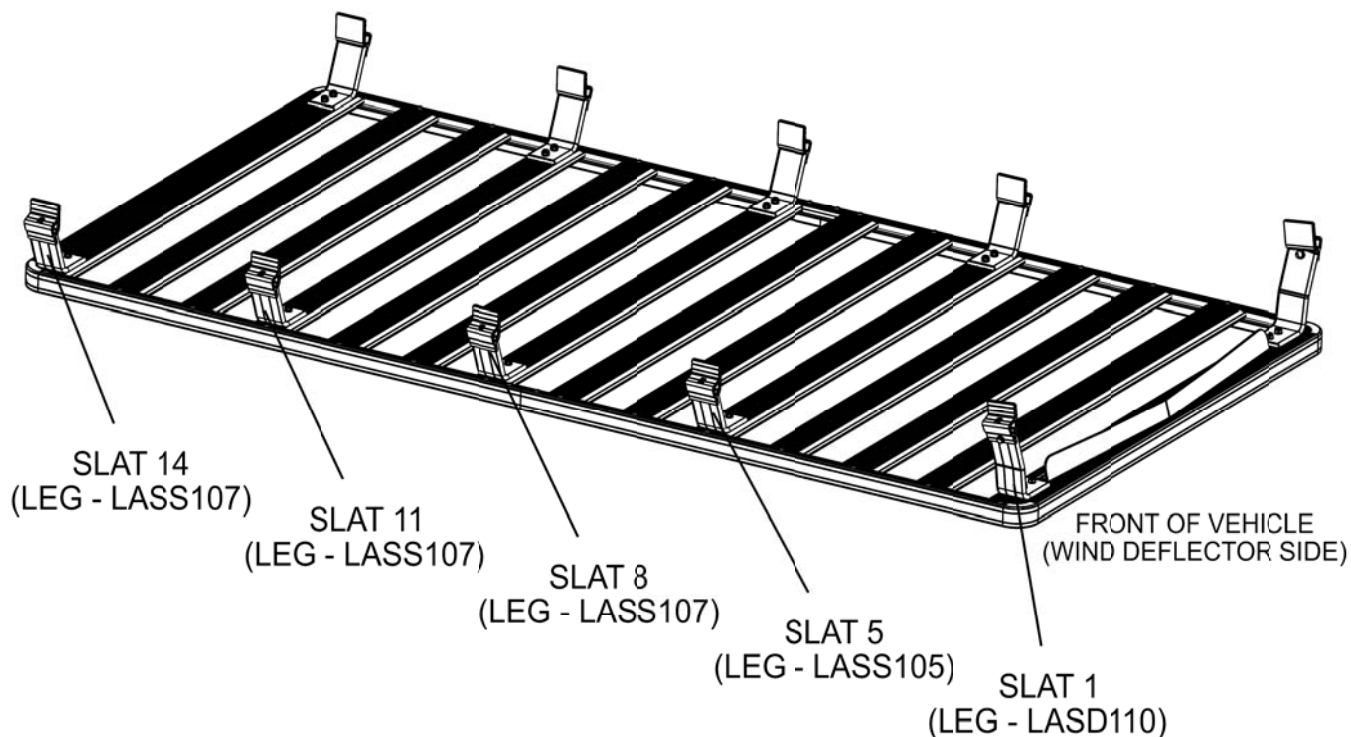

NOTE: DO NOT SLIDE THE RACK AND LEGS ACROSS THE ROOF! If there is a chance that you are going to set the roof rack on to the roof, place some moving blankets and/or towels over the roof. If you must lower the rack before it is in position, carefully set the Feet on the padded surface.

Once your Slimline II Roof Rack is fitted, ensure a 15mm clearance is maintained between the Wind Deflector and the vehicles roof otherwise damage to the roof may occur. Bend the Wind Deflector by hand if necessary.



3 MOUNT THE RACK TO YOUR VEHICLE

REFER TO LEG ASSEMBLY INSTRUCTION (DOCUMENT LASSIUNI)

- (**A**) Grab your friend and with one of you on each side of the Rack, flip the rack end over end (Prevents the Hex Bolts from falling out the machines slots) so that the Legs are facing down. With the Wind Deflectors facing forward, approach the vehicle from the rear lifting the Rack up and over the roof.

Position the Rack as far back as possible without it overhanging the rear of the vehicle. Bring the rack down slowly making sure that the Legs go directly into the gutters of the vehicle.

Center the Rack left to right. Ensure that the Rack is level - front to back and left to right - before fastening.

Congratulations, you have completed your installation. Take a step back and admire your work. Good Job!

4 TAKE A TRIP

- (**A**) After your first adventure, check that all nuts, bolts, screws and fittings are tight. Re-tighten where needed. You'll find a small amount of settling has happened.

Go on many more adventures, periodically checking all nuts, bolts, screws and fittings.



Front Runner can not recommend a maximum load carrying capacity. Please refer to your vehicle manufacturer's recommendations.



FRONT RUNNER
VEHICLE OUTFITTERS

LEG ASSEMBLY

LASSUNI

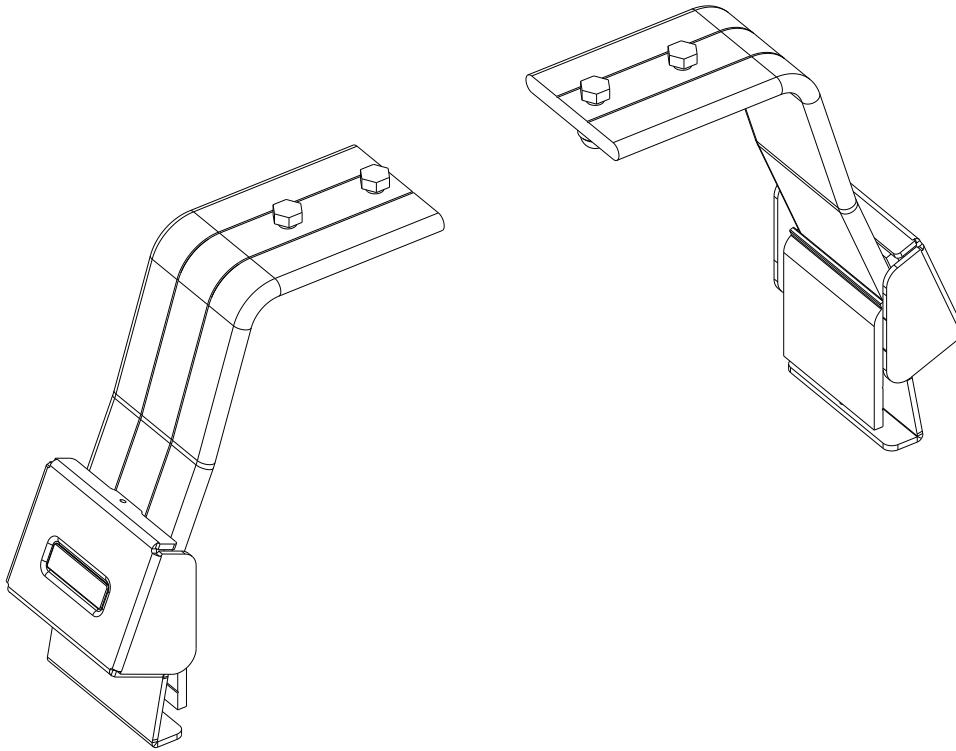

READ ME !

Thank you for purchasing a Front Runner Leg Assembly.

Before you start, take a moment to familiarize yourself with the Fitting Instructions and the components received.

Refer to Page 2 for a list of all the components, quantities and tools required.

IMPORTANT WARNING!

IT IS CRITICAL THAT ALL FRONT RUNNER PRODUCTS BE PROPERLY AND SECURELY ASSEMBLED AND ATTACHED TO YOUR VEHICLE. IMPROPER ATTACHMENT COULD RESULT IN AN AUTOMOBILE ACCIDENT, AND COULD CAUSE SERIOUS BODILY INJURY OR DEATH. YOU ARE RESPONSIBLE FOR ASSEMBLING AND SECURING ALL FRONT RUNNER PRODUCTS TO YOUR VEHICLE, CHECKING THE ATTACHMENTS PRIOR TO USE, AND PERIODICALLY INSPECTING THE PRODUCTS FOR ADJUSTMENT, WEAR AND DAMAGE. THEREFORE, YOU MUST READ AND UNDERSTAND ALL OF THE INSTRUCTIONS AND PRECAUTIONS SUPPLIED WITH YOUR FRONT RUNNER PRODUCT PRIOR TO INSTALLATION OR USE. IF YOU DO NOT UNDERSTAND ALL OF THE INSTRUCTIONS AND CAUTIONS, OR IF YOU HAVE NO MECHANICAL EXPERIENCE AND ARE NOT THOROUGHLY FAMILIAR WITH THE INSTALLATION PROCEDURES, YOU SHOULD HAVE THE PRODUCT INSTALLED BY A PROFESSIONAL INSTALLER OR OTHER QUALIFIED PERSONNEL.

NOTE: Front Runner will not be responsible for any damage caused by the failure to install the product according to these instructions.

1**GET ORGANIZED****IN THE BOX**

1	2 X	Leg
2	4 X	M8 x 25 Hex Bolt
3	2 X	M8 x 16 x 1.6SS Flat Washer
4	4 X	M8 Nyloc Nut
5	4 X	M8 Nut Cap
6	2 X	Gutter Clamp
7	2 X	M8 SS Spring Washer
8	2 X	M8 x 30 Button Head Bolt
9	2 X	Diagonal Leg
10	2 X	Leg Base

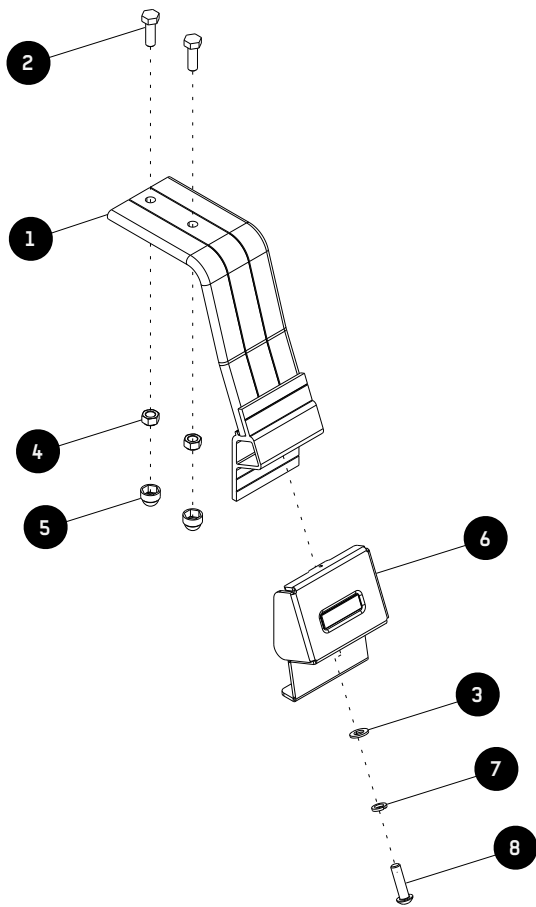
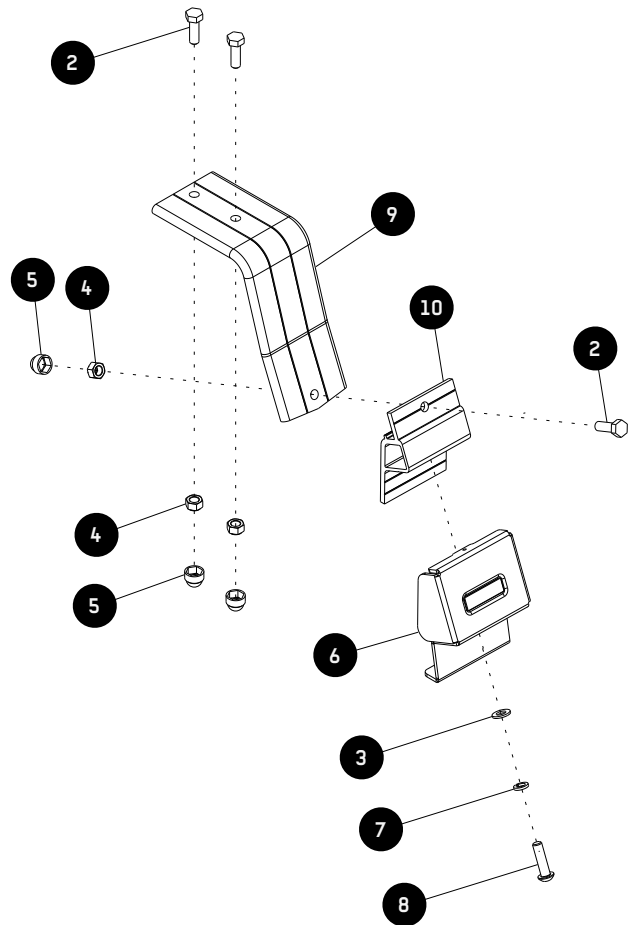
TOOLS NEEDED**FIGURE 1.1 - LEG****FIGURE 1.2 - DIAGONAL LEG**

2**FIT AND SECURE**

2.1

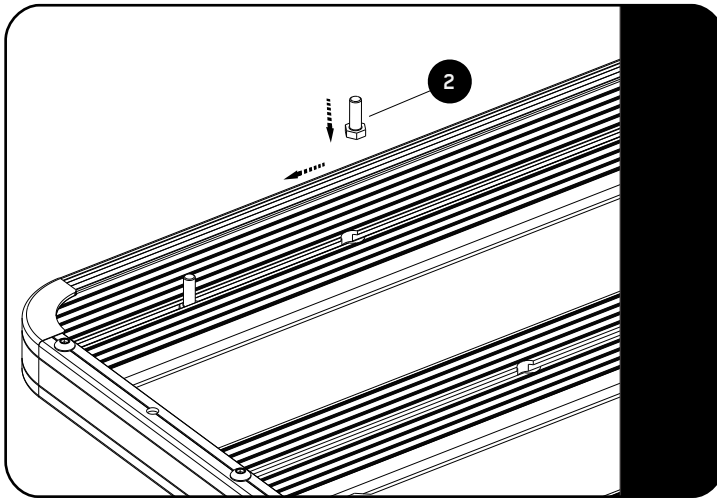

RECOMMENDED SPACING BETWEEN LEGS OR FEET ARE 3 SLATS.

SPACING MAY NOT EXCEED 4 SLATS.



Slide two M8 x 25 Hex Bolts (Item 2) into the Slats machined slots.

2.2

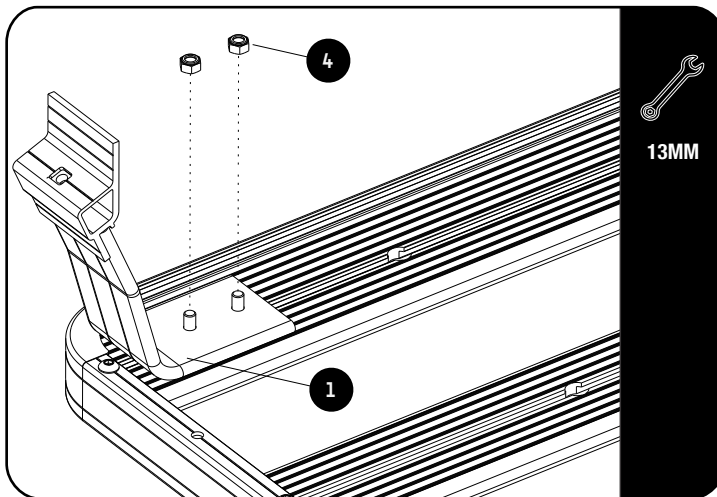

IF YOU ARE FITTING A DIAGONAL LEG, REFER TO FIGURE 1.2 FOR ASSEMBLY.



Loosly fit the Legs (Item 1 OR 9) using M8 Nyloc Nuts (items 3 & 4)

Flip the Rack over and position over the vehicle's roof. Let a friend help. Check that all the legs are seated in the gutter.

Check that the leg is correctly seated under the rack and adjust if needed. Fully tighten the leg to the rack and place Nut caps over all the nuts.



Tightening Torque 25Nm / 18.4 ft lbs

2.3

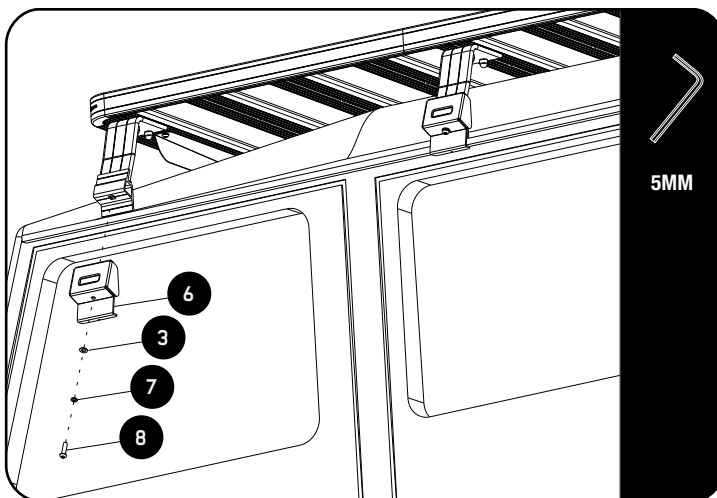

Secure the Gutter Clamps (Item 6) using M8 x 30 Button Heads, M8 Spring Washers and M8 x 16 x 1.6 Flat Washers (Items 3, 7 & 8). Check that the Clamp is seated correctly under the gutter before tightening.



Tightening Torque 16Nm / 11.8 ft lbs

3

FINISH

Congratulations! You did it. Take a step back and admire your work!

4

INSTALL OTHER VEHICLE AND RACK ACCESSORIES