



FRONT RUNNER

**FRONT / REAR
EXPEDITION RAIL KIT**

KRX*001



INSTALL TIME: 30 mins

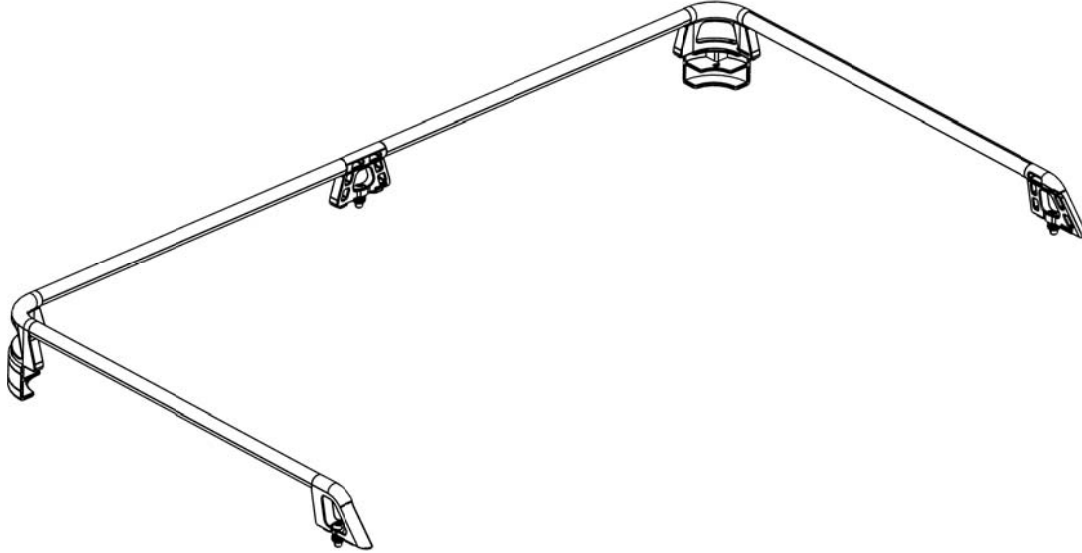

IMPORTANT INFORMATION

If your Rack has already been fitted to your vehicle, you will need to remove the Rack in order to fit the Expedition Rails. Start by removing all heavy items from the Rack. Depending on the mounting system used follow one of the three steps listed below to remove the Rack.

LEGS: Loosen and remove all the Clamps securing the Legs to the vehicle's gutters. Lift the Rack and walk it backwards and off the vehicle. Take care not to scratch the vehicle roof.

Track & Feet: Loosen and remove all of the MIDDLE bolts securing the top and bottom halves of the feet together. Lift the Rack and walk it backwards and off the vehicle. Take care not to scratch the vehicle roof.

Foot Rail: Loosen and remove all the nyloc nuts securing the Rack to the Foot Rails. Lift the Rack and walk it backwards and off the vehicle. Take care not to scratch the vehicle roof.



IMPORTANT WARNING!

IT IS CRITICAL THAT ALL FRONT RUNNER PRODUCTS BE PROPERLY AND SECURELY ASSEMBLED AND ATTACHED TO YOUR VEHICLE. IMPROPER ATTACHMENT COULD RESULT IN AN AUTOMOBILE ACCIDENT, AND COULD CAUSE SERIOUS BODILY INJURY OR DEATH TO YOU OR TO OTHERS. YOU ARE RESPONSIBLE FOR ASSEMBLING AND SECURING ALL FRONT RUNNER PRODUCTS TO YOUR VEHICLE, CHECKING THE ATTACHMENTS PRIOR TO USE, AND PERIODICALLY INSPECTING THE PRODUCTS FOR ADJUSTMENT, WEAR, AND DAMAGE. THEREFORE, YOU MUST READ AND UNDERSTAND ALL OF THE INSTRUCTIONS AND CAUTIONS SUPPLIED WITH YOUR FRONT RUNNER PRODUCT PRIOR TO INSTALLATION OR USE. IF YOU DO NOT UNDERSTAND ALL OF THE INSTRUCTIONS AND CAUTIONS, OR IF YOU HAVE NO MECHANICAL EXPERIENCE AND ARE NOT THOROUGHLY FAMILIAR WITH THE INSTALLATION PROCEDURES, YOU SHOULD HAVE THE PRODUCT INSTALLED BY A PROFESSIONAL INSTALLER OR OTHER QUALIFIED PERSONNEL.

1 GET ORGANIZED

Here is what you are looking at:

Item #	Quantity	Description
1	3	M8 x 25 BUTTON HEAD BOLT
2	1	JOINER PIECE
3	3	M8 NYLOC NUT
4	2	M6 x 12 BUTTON HEAD BOLT
5	2	PIPE A - LONG PIPE
6	2	CORNER PIECE
7	2	PIPE B - SHORT PIPE
8	2	END PIECE - 1 LEFT, 1 RIGHT
9	4	C-CLIP SPACER

You will need:

- 4 mm Hex Key
- 5 mm Hex Key
- Hack Saw
- Suitable Marker
- Measuring Tape

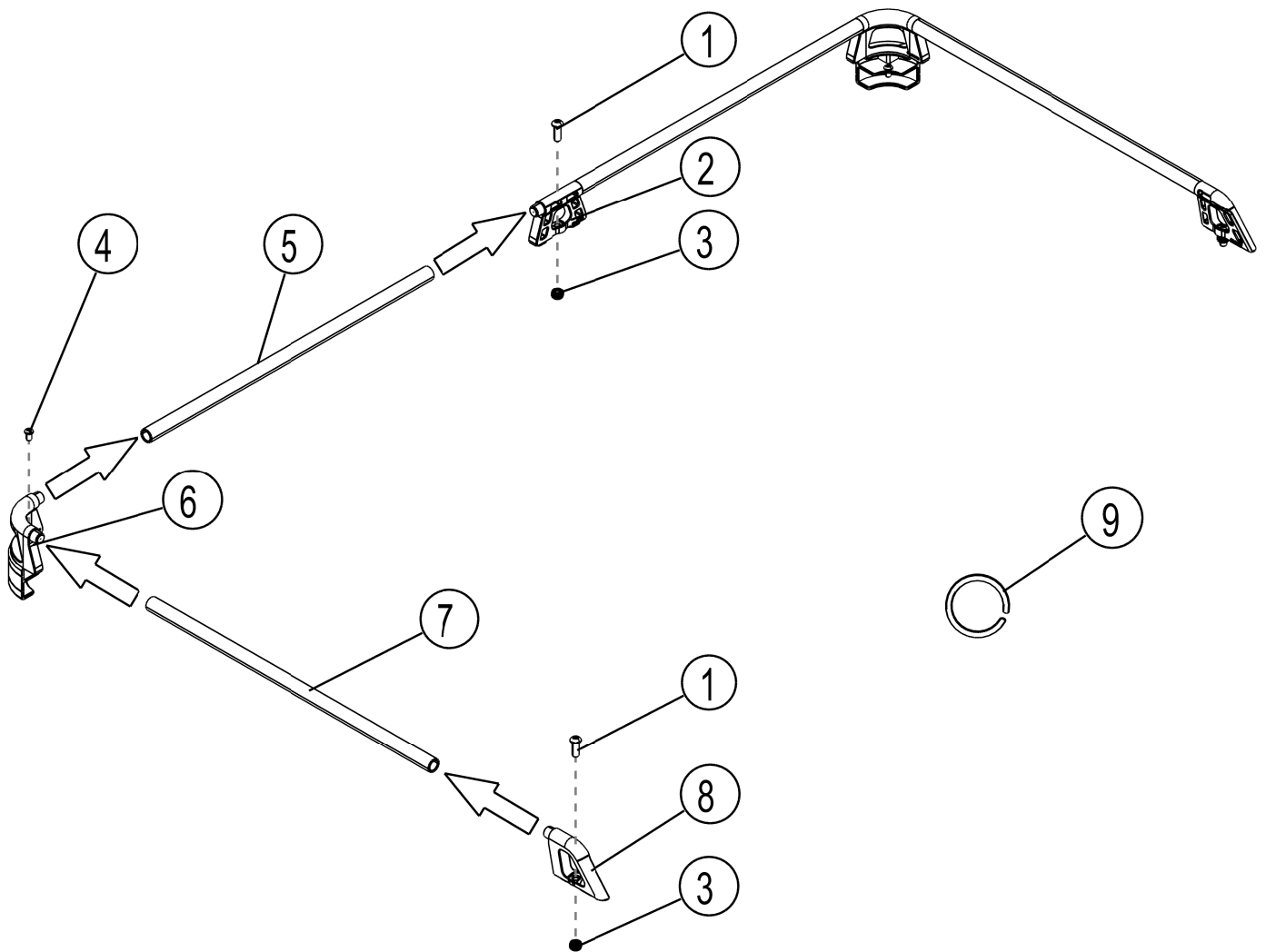

(A) Familiarize yourself with the parts and then step away from the work area and read through these instructions from beginning to end. Take a moment as a little prep now may save you a lot of time later.

2

FIT YOUR EXPEDITION RAILS

- (A) Decide whether you would like to fit your Expedition Rails to the front or rear of your Rack. Working on the chosen side, loosen the M6 Button Head Bolt securing the left and right hand side corners in position and remove the Corner of the Rack by pulling it away from the Rack.

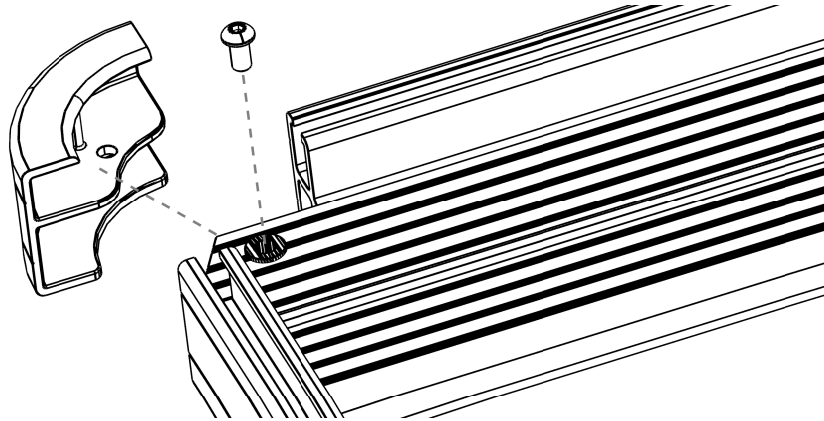

- (B) Loosely assembled a M8 x 25 Hex Bolt and M8 Nyloc Nut to the two End Pieces and Joiner Piece (Items 1, 2, 3, 8).

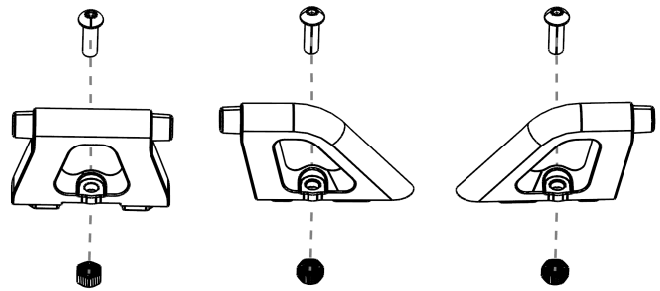

- (C) Referring to the images below, slide the two End Piece assemblies and the Joiner Piece assembly from Step 2B into the "u" channel of the Rack as shown.

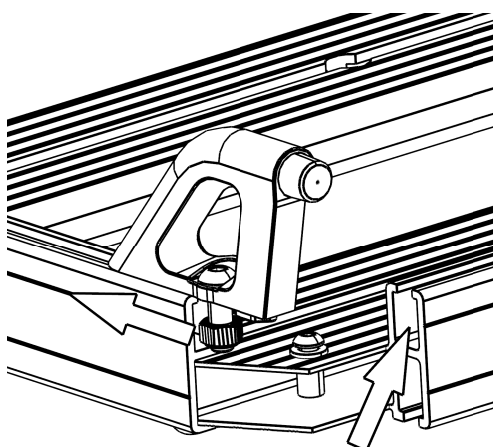

"U" Channel

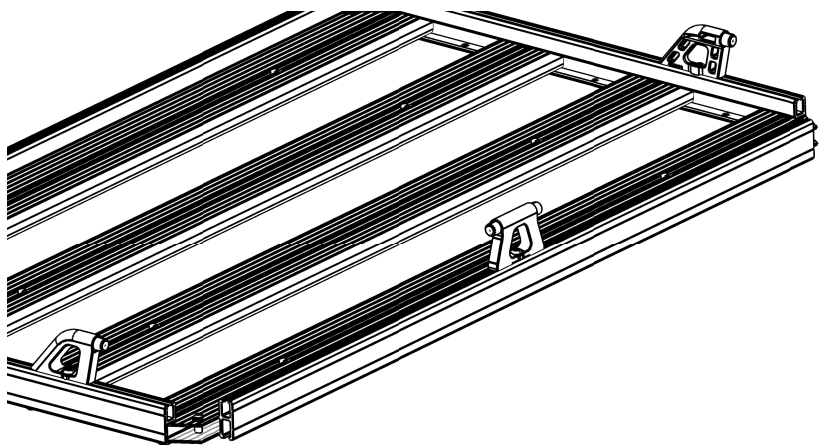

2**FIT YOUR EXPEDITION RAILS CONT...**

- (D) Starting on one of the Corners, loosen and remove the M8 Button Head Bolt securing the End Slat in position and slide / pull the Rear Slat backwards as shown.

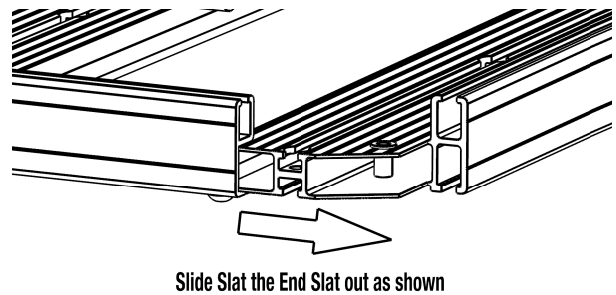
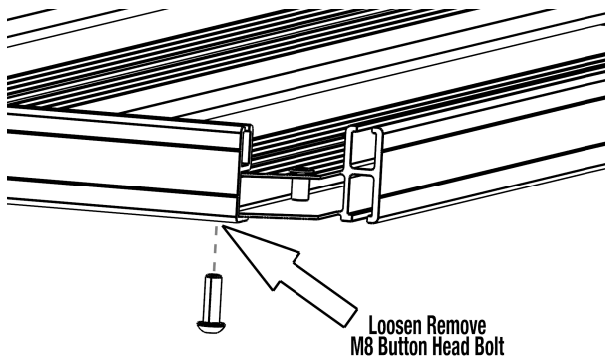

- (E) Slide a Corner Piece (Item 6) into the Rear Slat making sure that the Lip on the underside of the Corner Piece slides into the Top Lip of the "U" Channel. Once the Corner Piece is all the way into the Rear Slat, slide the Corner Piece and Rear Slat assembly onto the side of the Rack as shown. Secure the Rear Slat into position using the M8 Button Head Bolt removed in Step 2D. Secure the Corner Piece to the Rack using one of the M6 x 12 Button Head Bolts (Item 4) supplied.

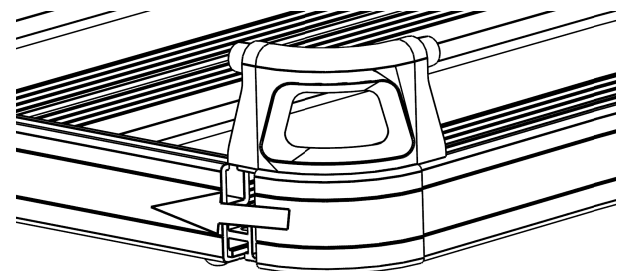
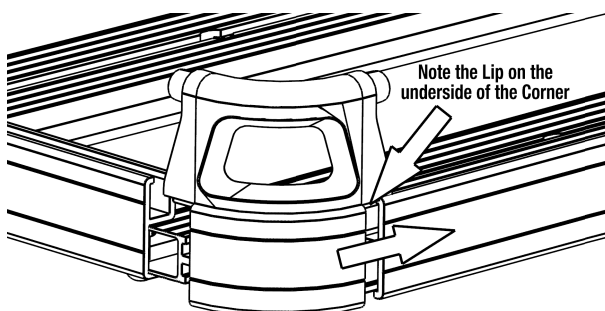

- (F) Referring Steps 2D & E, loosen and slide the open end of the Rear Slat out. Assemble the Steel Pipes (Item 5), Joiner Piece and remaining Corner Piece together as shown below and slide the Rear Slat with assembled components back into position. Secure the Rear Slat, Corner Piece and Joiner Piece in position.

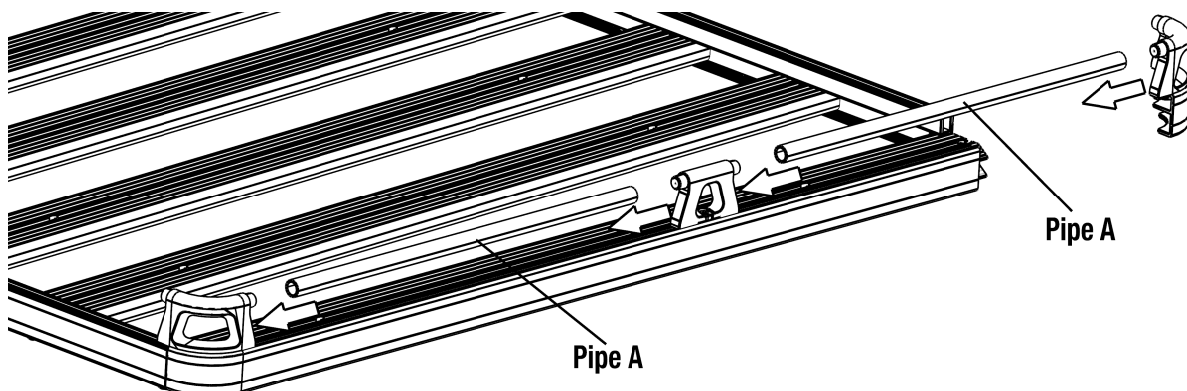

2 FIT YOUR EXPEDITION RAILS CONT...



Depending on the width and length of your Rack the two Steel Pipes that go on the side of the Rack may need to be cut shorter in order to fit onto the Rack correctly.

- (G) Assemble Pipes B (Item 7) to the side of the Rack as shown below. Once in position secure the End Pieces in place.

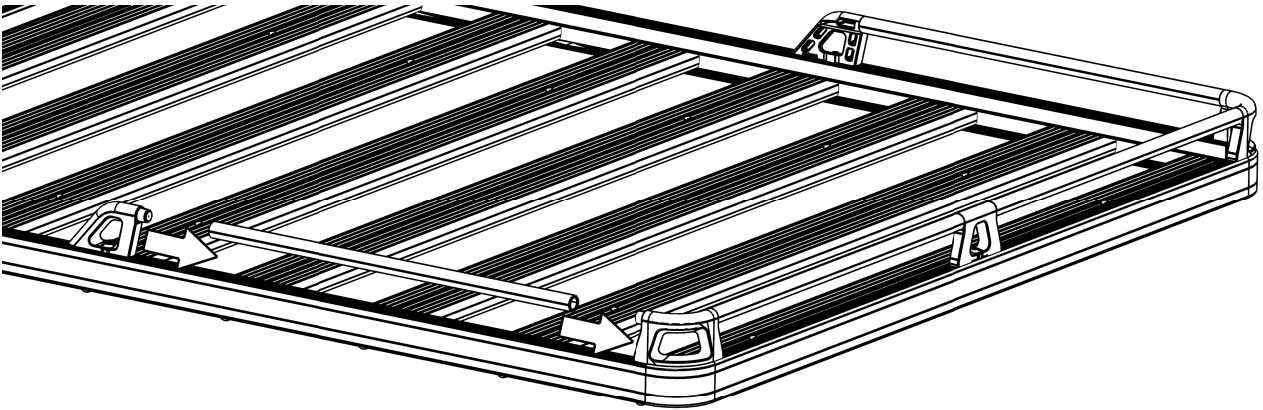

- (H) If either of the rear Pipes (Pipe A) are loose once your Expedition Rail has been assembled, you can loosen the appropriate section of Pipe and insert a C-clip Spacer (Item 9) over the taper of the Joiner or Corner as shown.

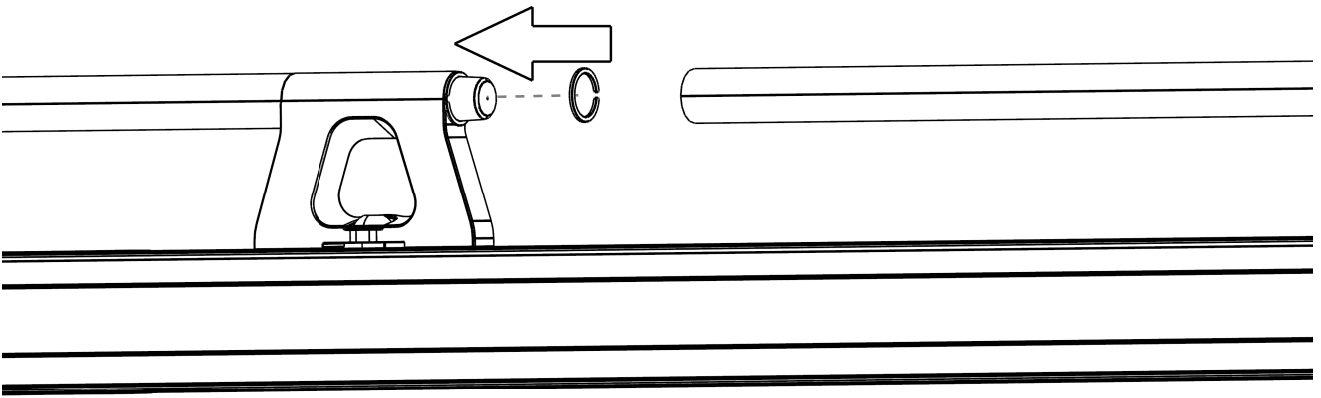

2 FIT YOUR EXPEDITION RAILS CONT...

- (I) Depending on your requirements and the size of your Rack, an additional Front / Rear Rail Kit or Full Kit may be fitted to your Rack as shown.

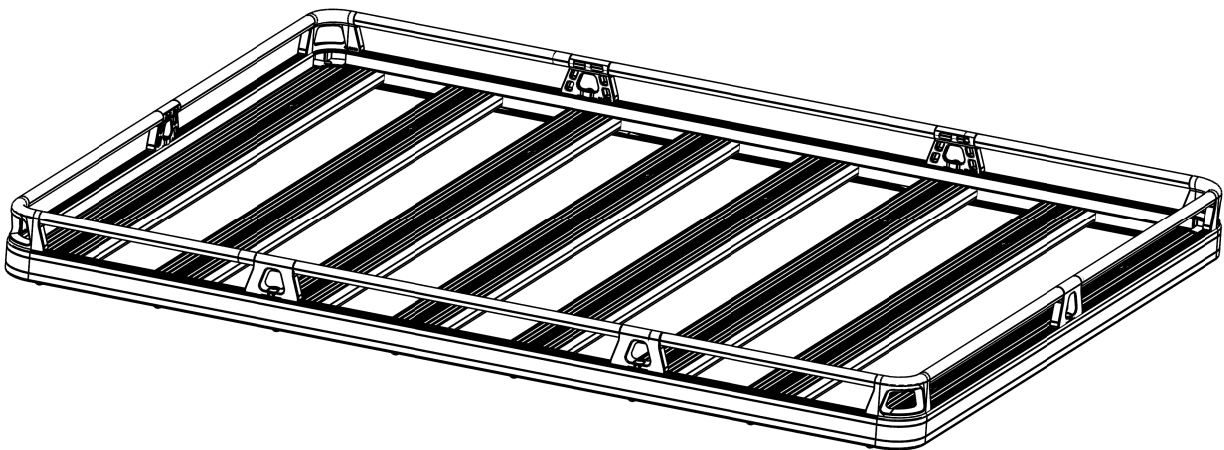
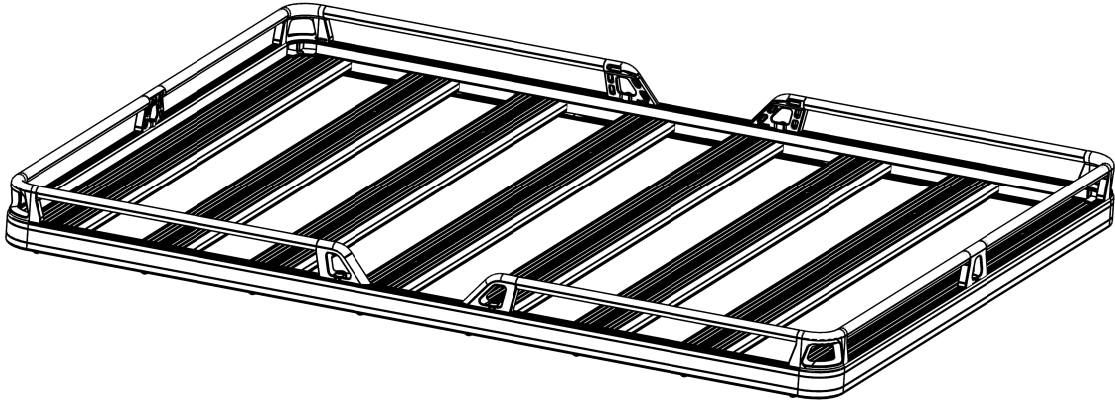

- (J) Congratulations, you have completed your installation. Take a step back and admire your work. Good Job!

3 INSTALL OTHER VEHICLE AND RACK ACCESSORIES



FRONT RUNNER

EXPEDITION FULL RAIL KIT

KRX*002



INSTALL TIME: 30 mins

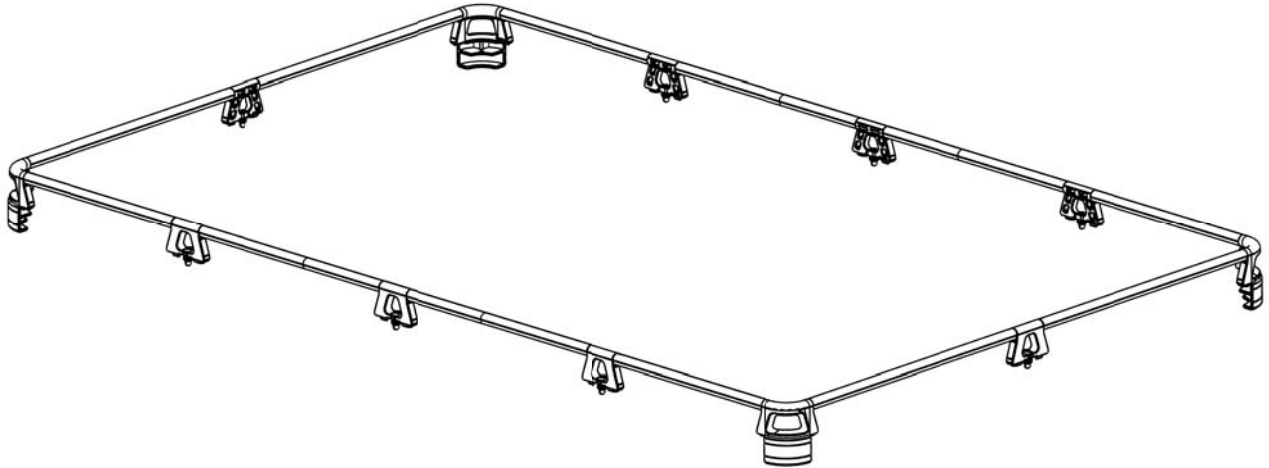

IMPORTANT INFORMATION

If your Rack has already been fitted to your vehicle, you will need to remove the Rack in order to fit the Expedition Rails. Start by removing all heavy items from the Rack. Depending on the mounting system used follow one of the three steps listed below to remove the Rack.

LEGS: Loosen and remove all the Clamps securing the Legs to the vehicle's gutters. Lift the Rack and walk it backwards and off the vehicle. Take care not to scratch the vehicle roof.

Track & Feet: Loosen and remove all of the MIDDLE bolts securing the top and bottom halves of the feet together. Lift the Rack and walk it backwards and off the vehicle. Take care not to scratch the vehicle roof.

Foot Rail: Loosen and remove all the nyloc nuts securing the Rack to the Foot Rails. Lift the Rack and walk it backwards and off the vehicle. Take care not to scratch the vehicle roof.

IMPORTANT WARNING!

IT IS CRITICAL THAT ALL FRONT RUNNER PRODUCTS BE PROPERLY AND SECURELY ASSEMBLED AND ATTACHED TO YOUR VEHICLE. IMPROPER ATTACHMENT COULD RESULT IN AN AUTOMOBILE ACCIDENT, AND COULD CAUSE SERIOUS BODILY INJURY OR DEATH TO YOU OR TO OTHERS. YOU ARE RESPONSIBLE FOR ASSEMBLING AND SECURING ALL FRONT RUNNER PRODUCTS TO YOUR VEHICLE, CHECKING THE ATTACHMENTS PRIOR TO USE, AND PERIODICALLY INSPECTING THE PRODUCTS FOR ADJUSTMENT, WEAR, AND DAMAGE. THEREFORE, YOU MUST READ AND UNDERSTAND ALL OF THE INSTRUCTIONS AND CAUTIONS SUPPLIED WITH YOUR FRONT RUNNER PRODUCT PRIOR TO INSTALLATION OR USE. IF YOU DO NOT UNDERSTAND ALL OF THE INSTRUCTIONS AND CAUTIONS, OR IF YOU HAVE NO MECHANICAL EXPERIENCE AND ARE NOT THOROUGHLY FAMILIAR WITH THE INSTALLATION PROCEDURES, YOU SHOULD HAVE THE PRODUCT INSTALLED BY A PROFESSIONAL INSTALLER OR OTHER QUALIFIED PERSONNEL.

1 GET ORGANIZED

Here is what you are looking at:

Item #	Quantity	Description
1	4	PIPE A *
2	4	PIPE B *
3	4	PIPE C - 700 mm LONG
4	8	JOINER PIECE
5	4	CORNER PIECE
6	8	M8 x 25 BUTTON HEAD BOLT
7	4	M6 x 12 BUTTON HEAD BOLT
8	8	M8 NYLOC NUT
9	16	C-CLIP SPACER

You will need:

- 4 mm Hex Key
- 5 mm Hex Key
- Hack Saw
- Suitable Marker
- Measuring Tape

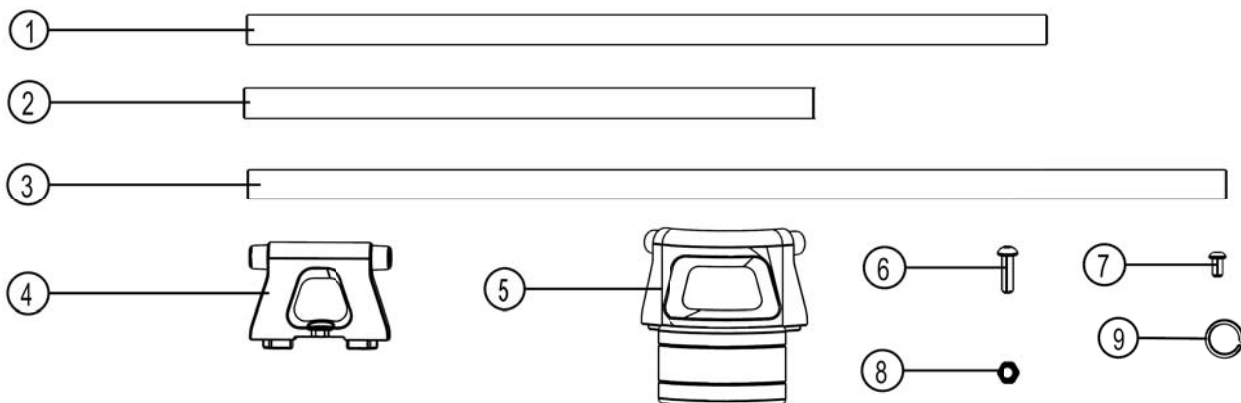

(A) * The lengths of Pipe A and Pipe B (Item 1 & 2) received in your Expedition Rail Kit will vary depending on the width and length of your Rack. Below are the various Rack widths and lengths of the two Pipes you should have received.

1165 Wide Rack: Pipe A - 480.5 mm
Pipe B - 365.5 mm

1425 Wide Rack: Pipe A - 610.5 mm
Pipe B - 570.5 mm

1255 Wide Rack: Pipe A - 525.5 mm
Pipe B - 365.5 mm

1475 Wide Rack: Pipe A - 480.5 mm
Pipe B - 570.5 mm

1345 Wide Rack: Pipe A - 570.5 mm
Pipe B - 570.5 mm

(B) The Illustrations on Page 3, show how the various components fit together and how your Expedition Rail will look depending on the width and length of your Rack. Refer for Appendix A to see which components will be used for your Rack.

If your Rack is 14 Slats or 2 772 mm Long, please refer to Page 7

(C) Familiarize yourself with the parts and then step away from the work area and read through these instructions from beginning to end. Take a moment as a little prep now may save you a lot of time later.

1

GET ORGANIZED CONT...



Depending on the width and length of your Rack not all components supplied will be used. Please refer to Appendix A at the back of this document for component requirements for each Rack. In each case it will be required to cut two or more pieces of Pipe C to length as per Appendix A.

Item #	Description
1	PIPE A
2	PIPE B
3	PIPE C

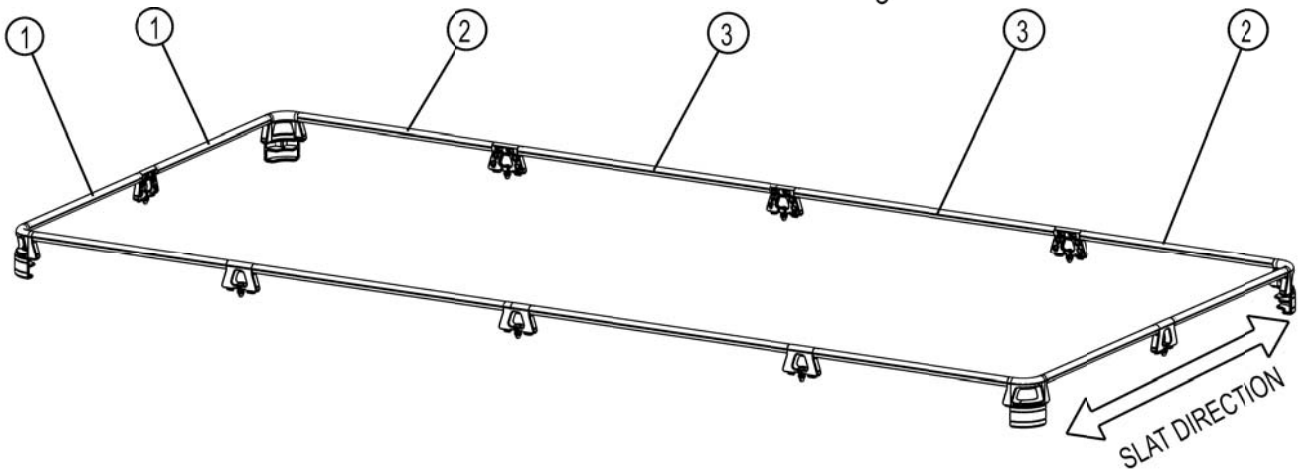
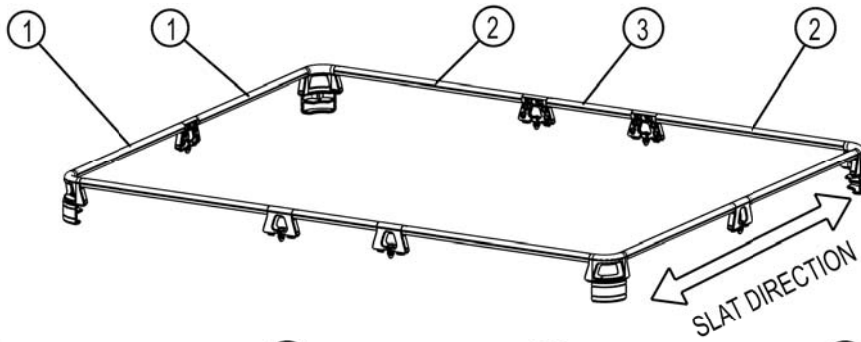
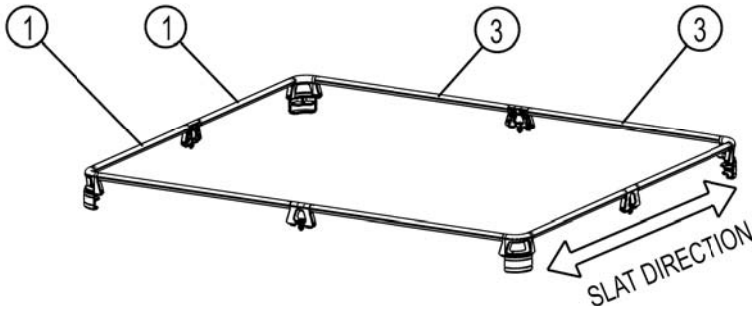
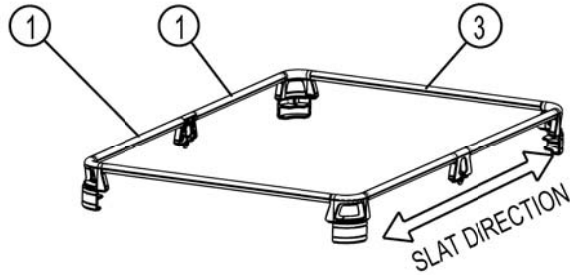

2

FIT YOUR EXPEDITION RAILS

(A) Referring to Appendix A, cut the required number of Pipe C to length.

(B) Referring to Appendix A, loosely assemble a M8 x 25 Hex Bolt and M8 Nyloc Nut to the required number of Joiner Pieces (Items 4, 6, 8).

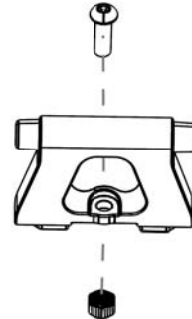

(C) Working at one end of your Rack, loosen the M6 Button Head Bolts securing the left and right hand side corners in position and remove the Corners from the Rack by pulling them away from the Rack.

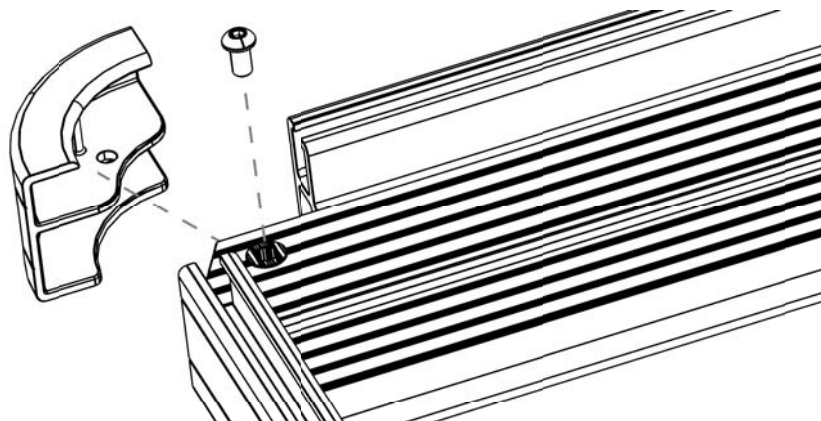

(D) Loosen and remove the M8 Button Head Bolt securing either end of the Slat in position and slide / pull the Slat backwards as shown.

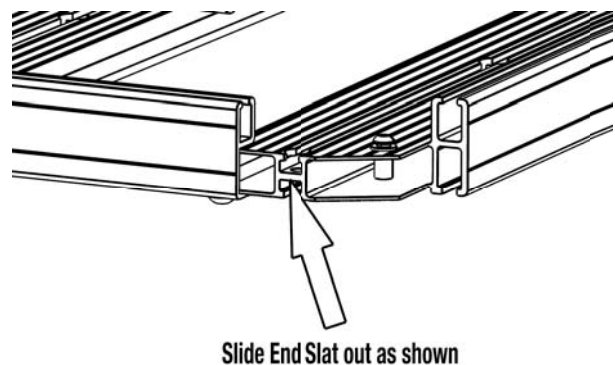
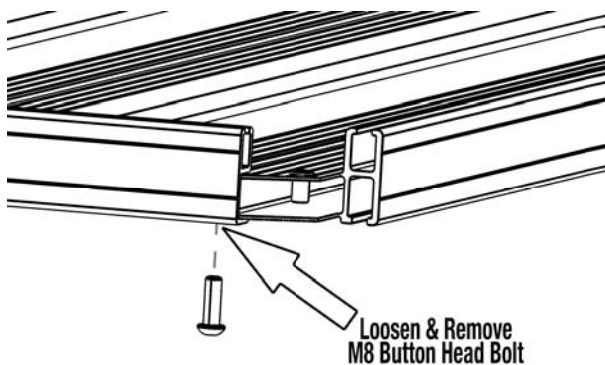

2

FIT YOUR EXPEDITION RAILS CONT...

- (E) Referring to the images below, insert one Joiner Piece assembly into the "U" Channel of the End Slat from Step 2D as shown. Depending on your Rack requirements (refer to Appendix A), slide either zero, one, two or three Joiner Piece assemblies into each side of the Rack. Depending on the length of your Rack, you may need to insert some of the Joiner Pieces before completing Step 2H due to the Rack joiner pieces that sit in the "U" Channel.

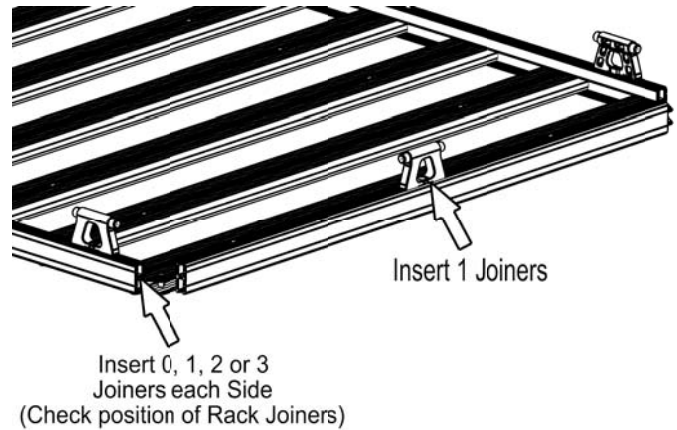
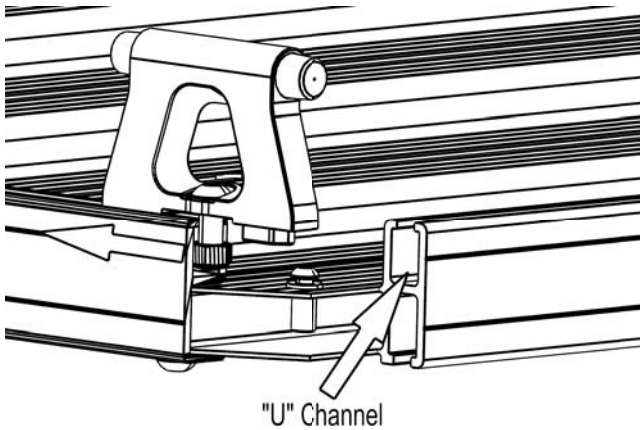

- (F) Slide a Corner Piece (Item 6) into the Slat making sure that the Lip on the underside of the Corner Piece slides into the Top Lip of the "U" Channel. Once the Corner Piece is all the way into the Rear Slat, loosely secure the Corner Piece to the Slat using one of the M6 x 12 Button Head Bolts (Item 4) supplied.

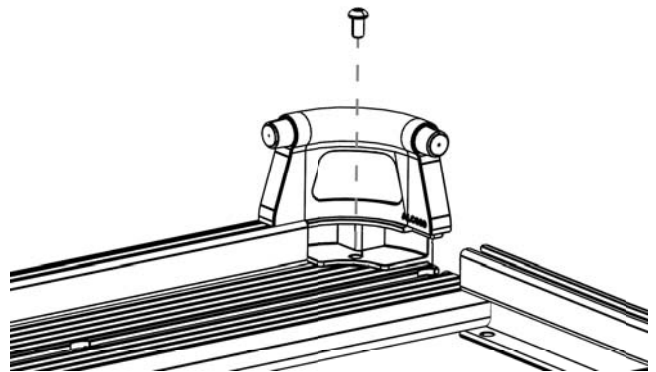
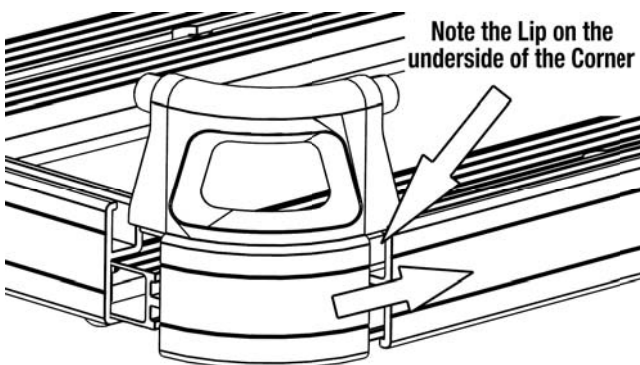

2

FIT YOUR EXPEDITION RAILS CONT...

- (G) Assemble two Pipe A's (Item 1), one Joiner Piece and one Corner Piece together as shown below. Loosely secure the Corner Piece in position and slide the Rear Slat with assembled components back into position and secure the Rear Slat to the Rack using the M8 x 25 Button Head Bolts removed in Step 2D.

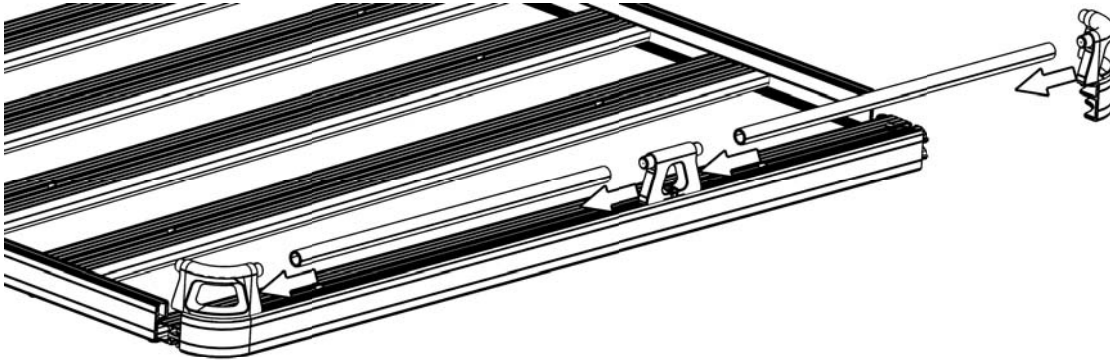

- (H) Repeat Steps 2C to 2G on the opposite side of the Rack, but do not slide the Slat Assembly back into position and secure. Remember to insert the Joiner Piece assemblies if required.

- (J) Referring to Page 3 and Appendix A, assemble the required number of Pipes B, Pipes C and Joiner Pieces together as shown.

- (K) Slide and fit the Slat assembly from Step 2H back into position and secure in place using the M8 x 25 Button Head Bolts removed in Step 2H.

- (L) If some of the Pipes are loose once your Expedition Rail has been assembled, you can loosen the appropriate section of Pipe and insert a C-clip Spacer (Item 9) over the taper of the Joiner or Corner as shown.

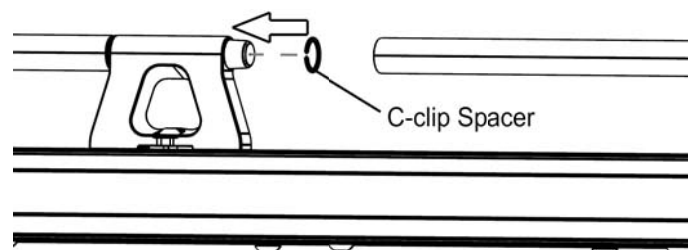

- (M) Ensure that all Bolts are fastened.

- (N) Congratulations, you have completed your installation. Take a step back and admire your work. Good Job!

3 FITMENT ON A 14 SLAT RACK

- (A) A 14 Slat Rack is the exception to the rule when fitting a full Expedition Rail due to the side profiles of the rack joining in the middle.

Some additional components not listed on Page 2 (but received in your kit) will be required. They are referred to as the End Pieces for the remainder of this document and are shown to the Right.

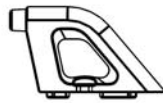

← Right Hand Side End Piece x 2

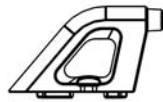

← Left Hand Side End Piece x 2

- (B) Following Steps 2A to 2G assemble the front and rear of the Expedition Rail taking note of the following.

Step2B: Assemble the four End Pieces in addition to the six Joiner Pieces.

Step2E: Insert one Joiner Piece into each End Slat (Front / Rear) as instructed. Insert one End Piece and one Joiner Piece through each corner into the side of the Rack as shown below.

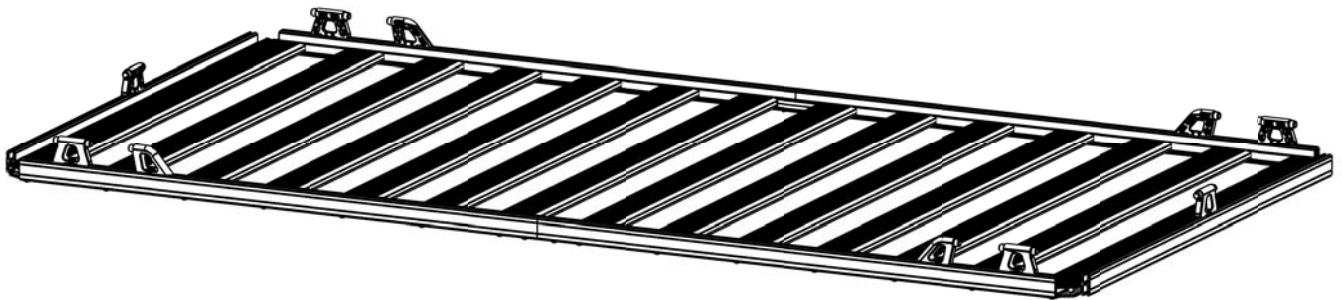

- (C) Assemble Pipe B and Pipe C to each "quarter" of the Rack as shown below and tighten all bolts. Should either of the rear pipe be loose, refer to Step 2L.

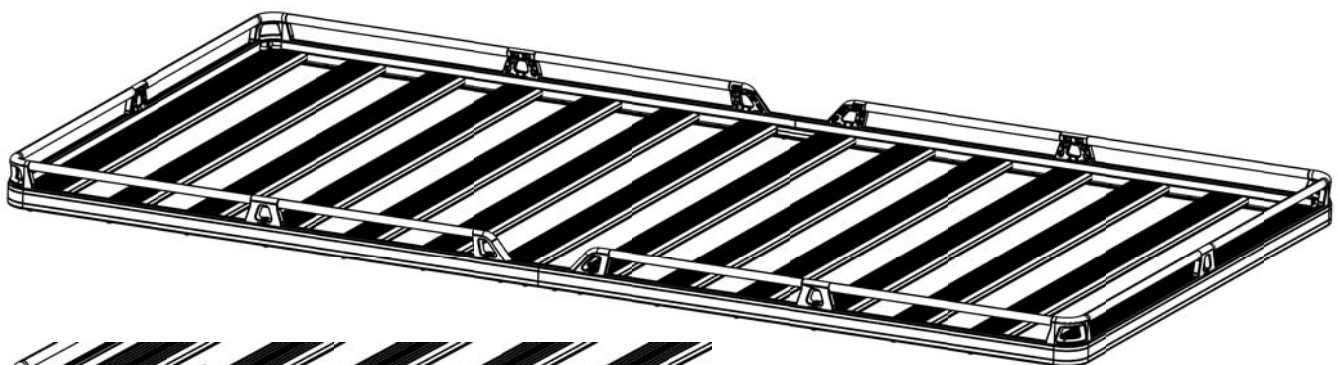

Pipe B

Pipe C

APPENDIX A

KRXA (1165mm Wide Rack)		Pipe A	Pipe B	Pipe C	
Rack Length: Number of Slats	Number of Joiners Required	Number of 480.5mm Pipes Required	Number of 365.5mm Pipes Required	Number of 700mm Pipes Required	Cut length Required
4	2	4		2	614
5	4	4		4	374
6	4	4		4	475
7	4	4		4	576
8	6	4	4	2	555
9	8	4	4	4	345
10	8	4	4	4	446
11	8	4	4	4	547
12	8	4	4	4	648
13					
14					

KRXD (1255mm Rack Width)		Pipe A	Pipe B	Pipe C	
Rack Length: Number of Slats	Number of Joiners Required	Number of 525.5mm Pipes Required	Number of 365.5mm Pipes Required	Number of 700mm Pipes Required	Cut length Required
4	2	4		2	614
5	4	4		4	374
6	4	4		4	475
7	4	4		4	576
8	6	4	4	2	555
9	8	4	4	4	345
10	8	4	4	4	446
11	8	4	4	4	547
12	8	4	4	4	648
13					
14					

KRXG (1345mm Rack Width)		Pipe A	Pipe B	Pipe C	
Rack Length: Number of Slats	Number of Joiners Required	Number of 570.5mm Pipes Required	Number of 570.5mm Pipes Required	Number of 700mm Pipes Required	Cut length Required
4	2	4		2	614
5	4	4		4	374
6	4	4		4	475
7	4	4		4	576
8	4	4		4	677
9	6	4	4	2	347
10	6	4	4	2	549
11	8	4	4	4	342
12	8	4	4	4	443
13	8	4	4	4	544
14	6	4	4	4	500

KRXJ (1425mm Rack Width)		Pipe A	Pipe B	Pipe C	
Rack Length: Number of Slats	Number of Joiners Required	Number of 610.5mm Pipes Required	Number of 570.5mm Pipes Required	Number of 700mm Pipes Required	Cut length Required
4	2	4		2	614
5	4	4		4	374
6	4	4		4	475
7	4	4		4	576
8	4	4		4	677
9	6	4	4	2	347
10	6	4	4	2	549
11	8	4	4	4	342
12	8	4	4	4	443
13	8	4	4	4	544
14	6	4	4	4	500

KRXM (1475mm Rack Width)		Pipe A	Pipe B	Pipe C	
Rack Length: Number of Slats	Number of Joiners Required	Number of 635.5mm Pipes Required	Number of 570.5mm Pipes Required	Number of 700mm Pipes Required	Cut length Required
4	2	4		2	614
5	4	4		4	374
6	4	4		4	475
7	4	4		4	576
8	4	4		4	677
9	6	4	4	2	347
10	6	4	4	2	549
11	8	4	4	4	342
12	8	4	4	4	443
13	8	4	4	4	544
14	6	4	4	4	500