



Installation Instructions

Cat-Back Single Exhaust

Nissan Pathfinder
4.0L, 2/4wd, 4dr.

Part #12210

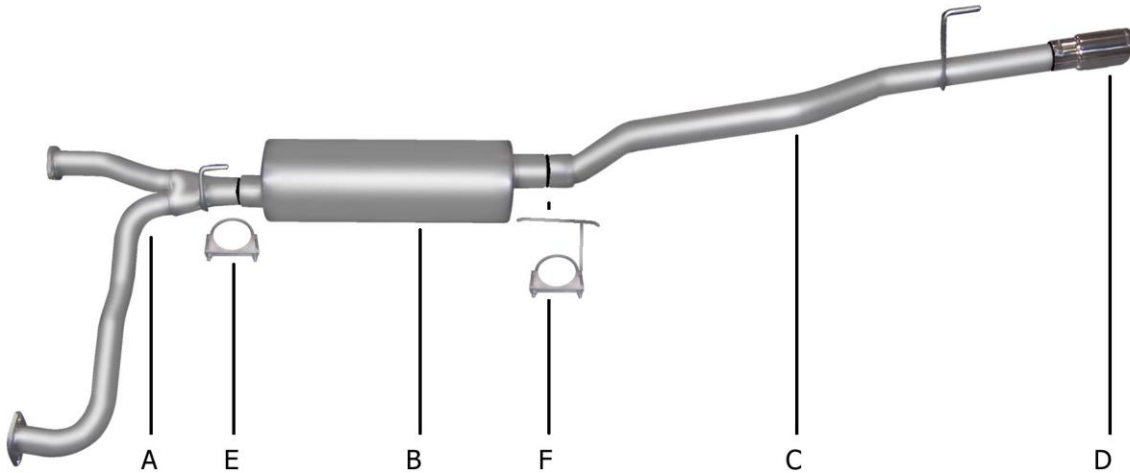

ITEM	PART	QUANTITY	DESCRIPTION
A	700631	1	2.5" Y-Pipe
B	788824	1	Superflow Muffler
C	700632	1	2.5" Tailpipe
D	500396	1	3.5" Stainless Tip
E	OHD300	1	3" Clamp
F	4235	1	2.5" Rear Muffler Hanger

Installation Instructions #12210

When installing this exhaust system make sure to use proper safety precautions. Use jack stands when working under the vehicle, set parking brake, block tires and use safety glasses and gloves. Allow exhaust to cool before attempting installation. Severe injury or burns could occur if safety measures are not taken.

SUGGESTED TOOLS: 1/2", 9/16", 15mm wrenches & sockets, WD-40, hacksaw, jack stands

1. Disconnect the negative battery cable before removal of OEM exhaust. This will allow the computer to reset and recognize the new exhaust. Lay out the exhaust on the floor so it looks like the drawing and compare parts with manual.



2. To remove the stock exhaust, unbolt the 2-bolt flanges located in front of your factory muffler. Next, unbolt your stock tailpipe behind your muffler. Do not discard your factory hardware, you will reuse it. (May need to remove spare tire for easier removal of tailpipe.)



6. Next, install rear muffler hanger #F onto outlet of muffler. Insert hanger into rubber grommet. Do not tighten.



3. Install Y-pipe #A onto your existing stock flanges. Insert hanger into rubber grommet. Use your factory hardware to secure. Do not tighten.



7. Install overaxle tailpipe #C into muffler 1.5"-2". Secure to the muffler using clamp #F. Do not tighten.



4. Install muffler #B onto headpipe #A 1.5"-2" with the louvers facing towards the converter. Use a jack stand to support the muffler. Use clamp #E to secure the muffler to the headpipe. Do not tighten. Muffler inlet is looking into the louvers. Outlet of muffler will be at the one o'clock position.



8. Install stainless steel tip. Clamp down. When you have everything in place, firmly tighten all bolts and clamps down securely. Start from the front of the system and work your way back. Use stainless steel cleaner and a Scotch Brite pad weekly to prevent tip from discoloration. Inspect all fasteners after 25-50 miles of operation and re-tighten as necessary.

GIBSON EXHAUST systems are designed on a factory stock vehicle
Any aftermarket products installed could increase the sound levels of the exhaust.

Make sure there is a 1" clearance from ALL rubber brake lines, shock boots, lines, tires, etc. to prevent heat related damage or fire.