

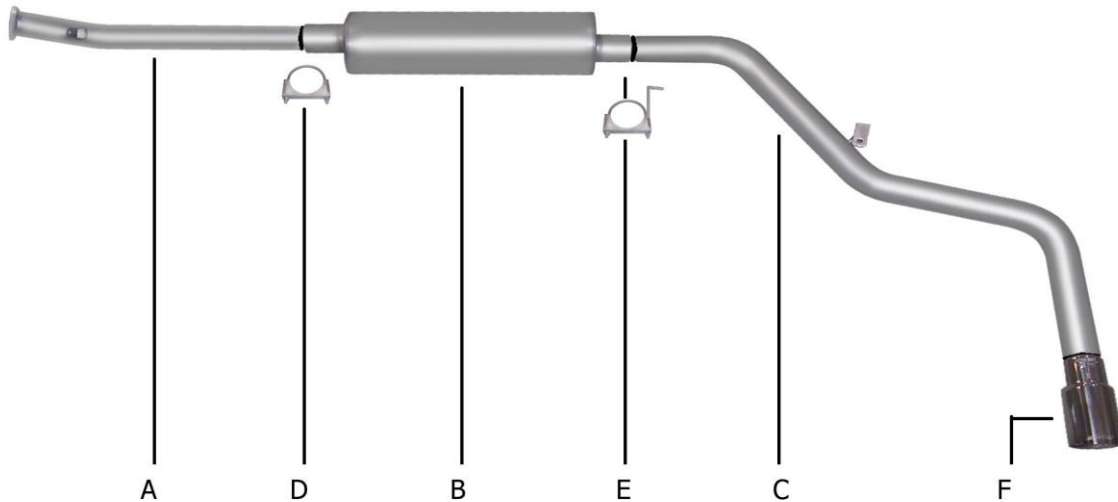

PERFORMANCE EXHAUST SYSTEMS

**INSTRUCTION MANUAL  
CAT BACK STAINLESS SINGLE EXHAUST  
NISSAN FRONTIER 3.3L  
CREWCAB, SHORTBED 2WD  
3.3L EXTENDED CAB, SHORTBED 2WD  
PART# 612202**

---



---

ITEM	PART #	QUANTITY	DESCRIPTION
A	451-700311S	1	STAINLESS HEADPIPE W/ FLANGE #GP-102
B	788200S	1	STAINLESS SUPERFLOW MUFFLER
C	452-700221S	1	2.5" STAINLESS TAILPIPE
D	5757	1	2.5" CLAMP
E	40104	1	2.5" CLAMP W/ HANGER
F	500361	1	3" STAINLESS TIP

---

# EXHAUST INSTALLATION

## PART #612202

WHEN INSTALLING THIS EXHAUST SYSTEM MAKE SURE TO USE PROPER SAFETY PRECAUTIONS. USE JACKSTANDS WHEN UNDER THE VEHICLE, SET PARKING BRAKE, BLOCK TIRES AND USE SAFETY GLASSES. **DO NOT WORK WITH HOT PIPES!!!**

### SUGGESTED TOOLS:

9/16" SOCKET, 1/2" WRENCH, HACKSAW, JACKSTANDS, WD-40, HI TEMP GASKET SEALER



LAY OUT THE GIBSON EXHAUST ON THE FLOOR AND COMPARE PART NUMBERS WITH THE MANUAL. LEAVE ALL FACTORY GROMMETS IN PLACE. FOR EASIER REMOVAL OF GROMMETS AND HANGERS USE WD-40 ON THEM.

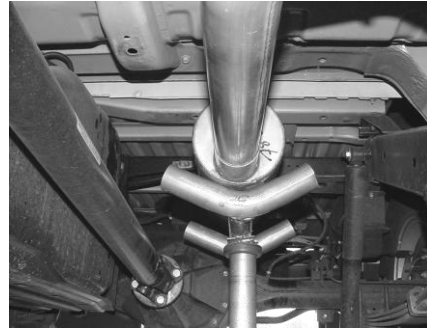

INSTALL THE MUFFLER ONTO THE HEADPIPE 1" TO 2". THE INLET OF THE MUFFLER WILL HAVE THE INSIDE LOUVERS FACING FORWARD. OUTLET WILL BE AT THE 12 O'CLOCK POSITION. DO NOT TIGHTEN. MUFFLER INLET IS LOOKING INTO LOUVERS.



REMOVE THE STOCK EXHAUST BY UNBOLTING THE 17MM BOLTS IN FRONT OF THE MUFFLER. UN-BOLT FACTORY HEADPIPE (YOU WILL RE-USE YOUR FLANGE BOLTS). DO NOT DAMAGE THE FACTORY GASKET YOU WILL NEED TO RE-USE! THEN CUT DIRECTLY BEHIND THE MUFFLER AND REMOVE THE STOCK EXHAUST.



SLIP THE OVER AXLE TAILPIPE #C INTO THE OUTLET OF THE MUFFLER 1" TO 2". CONNECT REAR HANGER WITH FACTORY BOLT. HANGER #I ON THE MUFFLER OUTLET. DO NOT TIGHTEN.



INSTALL THE HEADPIPE RE-USING THE FACTORY GASKET AND BOLTS. APPLY A SMALL AMOUNT OF HI-TEMP GASKET SEALER ONTO THE GASKET TO ENSURE A LEAK FREE CONNECTION. DO NOT TIGHTEN.



NEXT INSTALL YOUR STAINLESS STEEL TIP TO YOUR DESIRED LOOK. USE A STAINLESS OR ALUMINUM CLEANER TO POLISH TIP. NOW TIGHTEN ALL HANGERS AND CLAMPS STARTING FROM THE FRONT WORKING BACK.

**"MAKE SURE YOU HAVE A 1" CLERANCE ON ALL PIPES FROM ALL RUBBER BRAKE LINES, TIRES, SHOCK BOOTS, FUEL LINES, ETC..."**