



PERFORMANCE EXHAUST SYSTEMS

INSTRUCTION MANUAL

CAT-BACK STAINLESS SINGLE EXHAUST

TAHOE & YUKON 5.7L 2 DOOR 2/4WD

PART # 615501

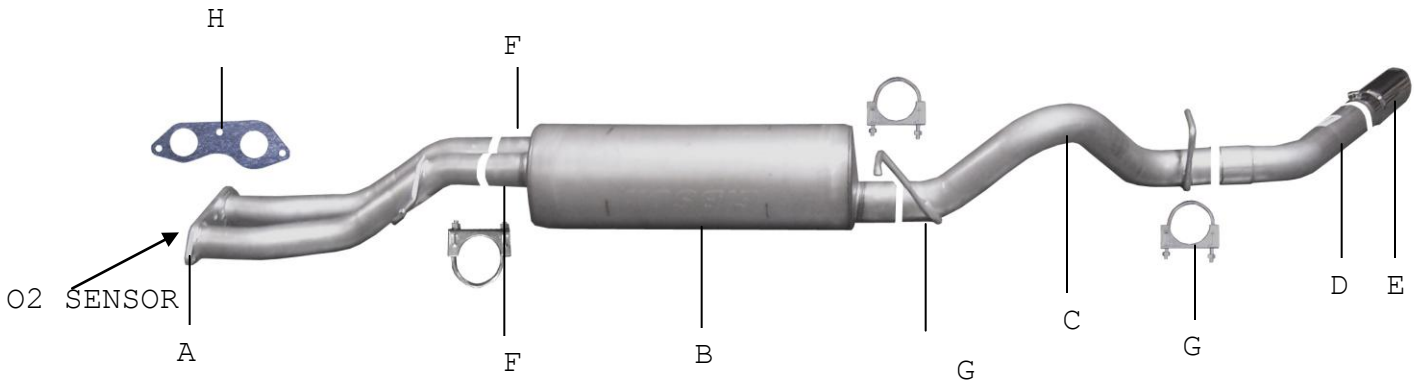

ITEM	PART #	QUANTITY	DESCRIPTION
A	178-500619S	1	STAINLESS HEADPIPE W/FLANGE GP-96
B	758250S	1	SUPERFLOW STAINLESS DUAL MUFFLER
C	179-500614S	1	3" STAINLESS OVERAXLE TAILPIPE
D	154-50032RS-2	1	3" STAINLESS TURNOUT PIPE
E	500360	1	3-1/2" STAINLESS STEEL TIP
F	5757	2	2-1/2" CLAMP
G	OHD300	2	3" CLAMP
H	9681	1	CONVERTER FLANGE GASKET

EXHAUST INSTALLATION #615501

WHEN INSTALLING THIS EXHAUST SYSTEM MAKE SURE TO USE ALL THE PROPER SAFTEY PRECAUTIONS. USE JACK STANDS WHEN UNDER TRUCK. SET PARKING BRAKE, BLOCK TIRES AND USE SAFTEY GOGGLES. DO NOT WORK WITH HOT PIPES!

SUGGESTED TOOLS

15MM SOCKET, 9/16" SOCKET, 1/2" SOCKET, 1/2" WRENCH, JACKSTAND, HACKSAW,WD-40, ANTI-SEIZE, HIGH TEMP O2 SENSOR SAFE GASKET SEALER

LAYOUT THE EXHAUST AND MATCH PART NUMBERS TO THE DRAWING.

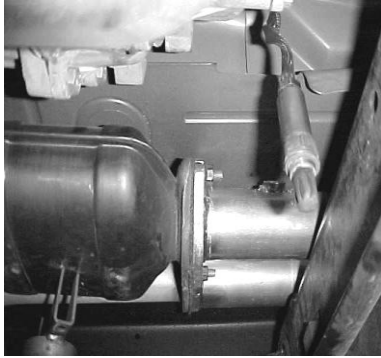

REMOVE O2 SENSOR FROM STOCK HEAD PIPE AND UN-BOLT STOCK HEAD-PIPE. YOU WILL REUSE YOUR STOCK NUTS AND BOLTS. CUT STOCK EXHAUST JUST BEHIND THE MUFFLER FOR EASIER REMOVAL. LEAVE ALL RUBBER GROMMETS IN PLACE. FOR EASIER REMOVAL OF HANGERS SPRAY WD-40 TO AID YOU IN REMOVING THEM.



INSTALL THE OVERAXLE TAILPIPE #C INTO MUFFLER AT LEAST 1 1/2" TO 2" USING CLAMP #G . DO NOT TIGHTEN. INSERT WELDED HANGERS INTO RUBBER GROMMETS. THE SPARE TIRE ON SOME VEHICLES MAY NEED TO BE LOOSEN ED AND PULLED TO THE DRIVER SIDE AND RE-TIGHTENED. ROTATE PIPES UNTIL YOU HAVE AT LEAST A 1" CLEARANCE AWAY FROM ALL PIPES, ETC.



BOLT HEADPIPE #A USING SUPPLIED FLANGE GASKET AND REUSING FACTORY BOLTS. APPLY A SMALL A MOUNT OF HIGH-TEMP O2 SENSOR SAFE SILICONE ON THE FLANGE TO PREVENT ANY LEAKS. INSERT WELDED HANGER INTO RUBBER GROMMET. DO NOT TIGHTEN



INSTALL TURNOUT PIPE #D INTO TAILPIPE USING CLAMP #G . INSTALL THE STAINLESS TIP AND CLAMP DOWN. USE ANY STAINLESS STEEL OR ALUMINUM CLEANER TO POLISH TIP.

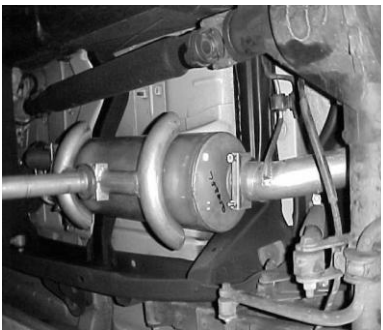

SLIDE MUFFLER WITH DUAL INLET ONTO HEADPIPE AT LEAST 1-1/2" TO 2". MUFFLER OUTLET SHOULD BE AT THE 12 O'CLOCK POSITION. USE CLAMPS #F TO ATTACH HEADPIPE. MAKE SURE INLETS AND MUFFLER IS LEVEL. AND TIGHTEN DOWN. USE JACK STAND TO SUPPORT MUFFLER.



RE-INSTALL O2 SENSOR. USE A SMALL AMOUNT ANTI-SIEZE ON THE THREADS. NOW FIRMLY TIGHTEN ALL CLAMPS, HANGERS, FLANGE, AND BOLTS.

MAKE SURE YOU HAVE A 1" CLEARANCE AWAY FROM ALL FUEL LINES, BRAKE LINES, ETC. SHOCK, TIRES, ETC...