

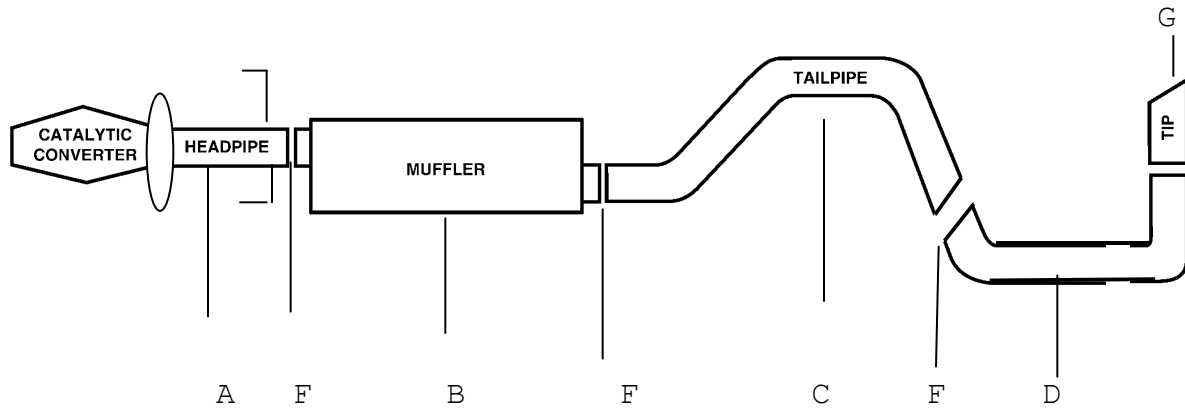

INSTRUCTION MANUAL

**CAT-BACK ELITE SINGLE EXHAUST
 FORD RANGER/MAZADA TRUCK
 2.3L, 3.0L, 4.0L 2/4WD
 STANDARD CAB, LONG BED
 PART#619705**



ITEM	PART #	QUANTITY	DESCRIPTION
A	267-25003S	1	S/S HEADPIPE WITH FLANGE #GP-102
B	788200S	1	SUPEFLOW S/S MUFFLER
C	217-25002S-B	1	2-1/2" S/S OVERAXLE PIPE
D	214-25002S-A	1	2-1/2" S/S TURNOUT PIPE
E	500361	1	3" STAINLESS TIP
F	5757	3	2-1/2" CLAMP

EXHAUST INSTALLATION

WHEN INSTALLING THIS EXHAUST SYSTEM MAKE SURE TO USE PROPER SAFETY PRECAUTIONS. ALWAYS BLOCK TIRES, USE JACK STANDS WHEN UNDER THE VEHICLE, ALONG WITH SAFETY GLASSES AND GLOVES. DO NOT WORK WITH HOT PIPES!

1. UNBOLT STOCK EXHAUST FROM BEHIND THE CATALYTIC CONVERTER. USE JACK STANDS TO SUPPORT CONVERTER.
 2. LAY OUT THE GIBSON EXHAUST SYSTEM ON THE FLOOR SO IT LOOKS LIKE THE DRAWING.
 3. INSTALL THE HEADPIPE AND BOLT TO THE EXISTING FLANGE.
 4. SLIDE MUFFLER WITH INLET TOWARDS THE CONVERTER ONTO THE HEADPIPE. USE A JACK STAND TO SUPPORT THE MUFFLER AND CLAMP DOWN BUT DO NOT TIGHTEN.
 5. INSTALL THE OVERAXLE TAILPIPE.
 6. SLIDE TURN OUT PIPE ON THE TAILPIPE BEHIND THE REAR TIRE AND CLAMP.
 7. INSTALL STAINLESS STEEL TIP. CLAMP DOWN. TO CLEAN STAINLESS STEEL TIP USE A SCOTCH BRITE PAD AND ANY STAINLESS STEEL OR ALUMINUM CLEANER.
 8. WHEN YOU HAVE EVERYTHING IN PLACE TIGHTEN ALL BOLTS AND CLAMP DOWN.
- ❖ **MAKE SURE YOU HAVE A 1" CLEARANCE ON ALL PIPES FROM ALL RUBBER BRAKE LINES, SHOCK BOOTS AND TIRES.**