

GIBSON

PERFORMANCE EXHAUST

INSTRUCTION MANUAL

CAT-BACK SINGLE STAINLESS EXHAUST

TOYOTA 4 RUNNER 2.7L 2WD 4DR

PART # 618100-B

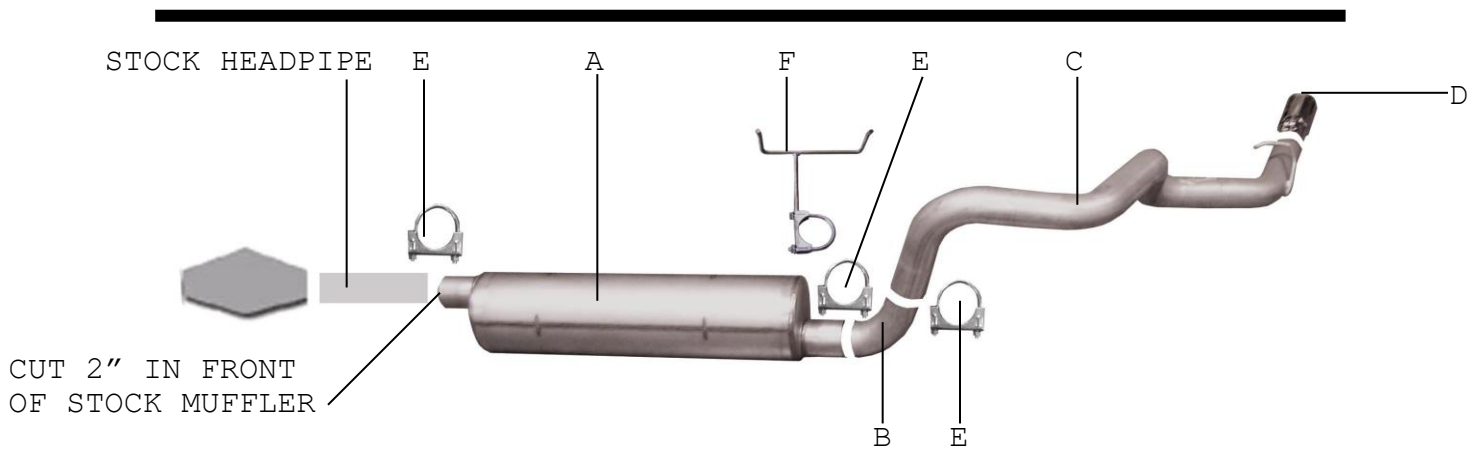

ITEM	PART #	QTY	DESCRIPTION
A	788500S-2	1	SUPERFLOW STAINLESS MUFFLER
B	241-500680S-A	1	2-1/2" STAINLESS FRONT TAILPIPE
C	242-500680S-B	1	2-1/2" STAINLESS OVERAXLE TAILPIPE
D	500640-B	1	BLACK STAINLESS TIP
E	5757	3	2-1/2" CLAMP
F	4105	1	REAR MUFFLER HANGER

EXHAUST INSTALLATION #618100-B

WHEN INSTALLING THIS EXHAUST SYSTEM, MAKE SURE TO USE PROPER SAFETY PRECAUTIONS. USE JACK STANDS WHEN UNDER TRUCK, BLOCK TIRES, USE SAFETY GLASSES AND GLOVES.

DO NOT WORK WITH HOT PIPES!

1. Lay out the GIBSON EXHAUST SYSTEM on the floor so it looks like the drawing and compare part numbers.
2. **Cut stock exhaust 2" in front of muffler using a hacksaw and remove stock exhaust leaving all of the factory rubber grommets.**
3. Slide muffler with inlet towards the converter onto the stock front pipe. Must be directly against the converter. Use a jack stand to support the muffler and clamp down using clamp #E but do not tighten. Muffler outlet should be approximately between 5-6 o'clock. Muffler inlet is looking into the louvers.
4. Install tailpipe # B with long side into the outlet of the muffler using #F clamp to muffler. Then install over axle tailpipe #C.
5. Install stainless steel tip. Clamp down. To clean stainless tip use a scott brite pad and any stainless steel or aluminum cleaner.
6. When you have everything in place, tighten all bolts and clamp down.

***MAKE SURE YOU HAVE A 1" CLEARANCE ON ALL PIPES FROM ALL FUEL & BRAKE LINES, SPARE TIRE, SHOCKS, TIRES, ETC.**