



PERFORMANCE EXHAUST SYSTEMS

INSTALLATION INSTRUCTIONS

Dual Split Rear Cat-Back
Chevy/GMC 1500 Crew Cab, Short Bed (5.8"), 5.3L 4wd

PART #65689

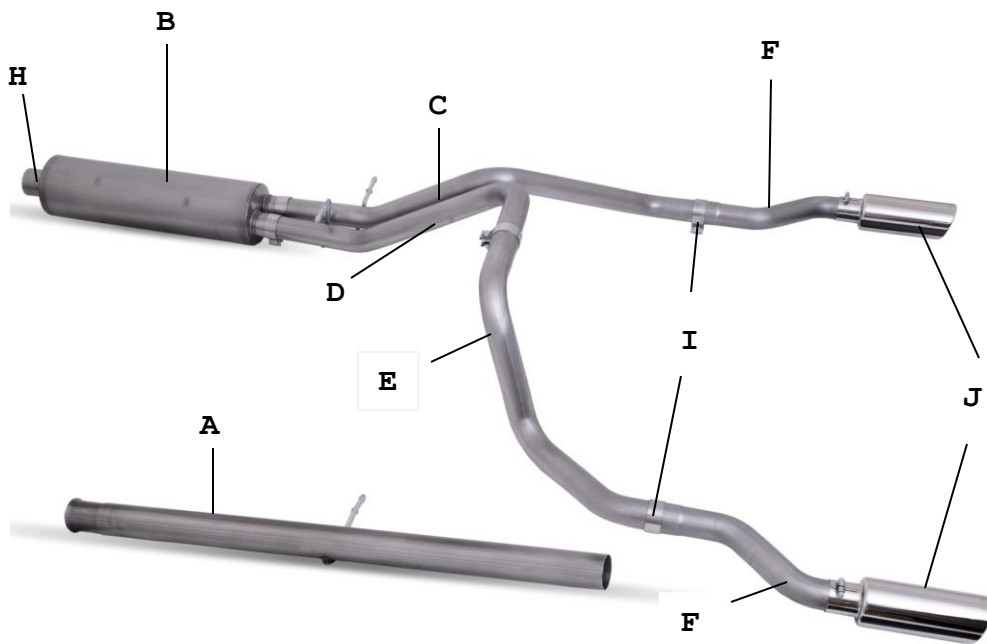

ITEM	PART #	QTY	DESCRIPTION
A	999701009S	1	3.0" Stainless Headpipe w/ Welded Hanger
B	789800S	1	SFT Stainless Superflow
C	999701015S	1	2.5" Passenger side Overaxle pipe
D	999701011S	1	2.5" Driver Side Overaxle pipe (A)
E	999701016S	1	2.5" Driver Side Overaxle pipe (B)
F	999701017S	2	2.5" Exit pipe
G	800040	1	Driver Side Rear Exhaust Hanger
H	5763	1	3.0" Stainless steel band clamp
I	5760	5	2.5" Stainless steel band clamp
J	500640	2	4.0" Rolled Polished Stainless steel tip's
H	4240	2	Rubber Grommet

EXHAUST INSTALLATION

PART# 65689

WHEN INSTALLING THIS EXHAUST SYSTEM MAKE SURE TO USE ALL THE PROPER SAFETY PRECAUTIONS. USE JACK STANDS WHEN UNDER TRUCK, SET PARKING BRAKE, BLOCK TIRES AND USE SAFETY GLASSES.

DO NOT WORK WITH HOT PIPES!!!

1. Disconnect the negative battery cable before removal of the OEM Exhaust. This will allow the computer to reset and recognize the new exhaust. Lay out the exhaust on the floor so it looks like the drawing and compare parts with manual. Remove the factory exhaust by cutting behind the factory muffler. Once the tail pipe has been removed un-bolt the muffler and head pipe at the flange located behind the catalytic converter. Use wd-40 or another type of penetrating oil to remove the rubber grommets. Do not damage these they will be re used.



2. Remove clamp from factory head pipe using a small flathead screwdriver to bend up the retaining clip and then install onto new head pipe (Item A). Next, install head pipe and tighten with allowance for adjustment.

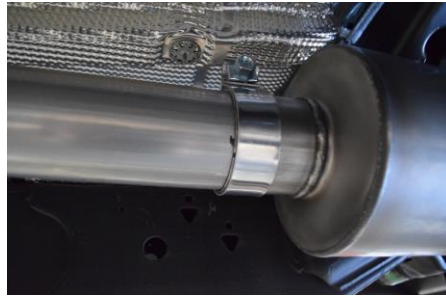

3. Install supplied 3" clamp (Item H) onto inlet end of new muffler (Item B) and slip onto end of the head pipe with 2-1/4" inserted into muffler. Tighten with allowance for adjustment.



4. Before install of (Item C) install supplied rubber hanger onto factory hanger mount (see picture). Install supplied 2-1/2" band clamp (Item I) onto inlet side of passenger side over-axle pipe (Item C) and install onto outlet of muffler. Install hanger into factory rubber grommet hanger. Tighten with allowance for adjustment.



5. Before install of item E, install Driver side hanger bracket as shown in picture. Install supplied 2-1/2" band clamp onto the inlet side of the driver side over-axle pipe A and install onto outlet of muffler. Install hanger into factory rubber grommet hanger. Next install another 2-1/2" band clamp onto the inlet side of driver side over-axle pipe B (Item E) and install onto outlet of Item D. Tighten both clamps with allowance for adjustment.



6. Install supplied 2-1/2" band clamp (Item I) onto the inlet side of both the Driver and Passenger side exit pipes (Item F) and install them onto the outlets of each over-axle pipe. Tighten both clamps with allowance for adjustment.



7. Rotate pipes as needed to achieve desired fit and adequate clearance of chassis and components. Start with the forward head-pipe clamp and work back towards the exit pipes securing each clamp joint along the way.

"MAKE SURE YOU HAVE A 1" CLEARANCE ON ALL PIPES FROM ALL RUBBER BRAKE LINES, SHOCK BOOTS, TIRES, ETC..." TORQUE ALL CLAMPS TO APPROX. 100 TO 150 FT LBS.

Rely only on high-grade performance exhaust systems offered on our virtual shelves.