



Installation Instructions

Cat-Back Stainless Dual Sport Exhaust

Toyota Tundra 4.6L, 4.7L, 5.7L 2/4wd

Double Cab, Long Bed

Part #67103B

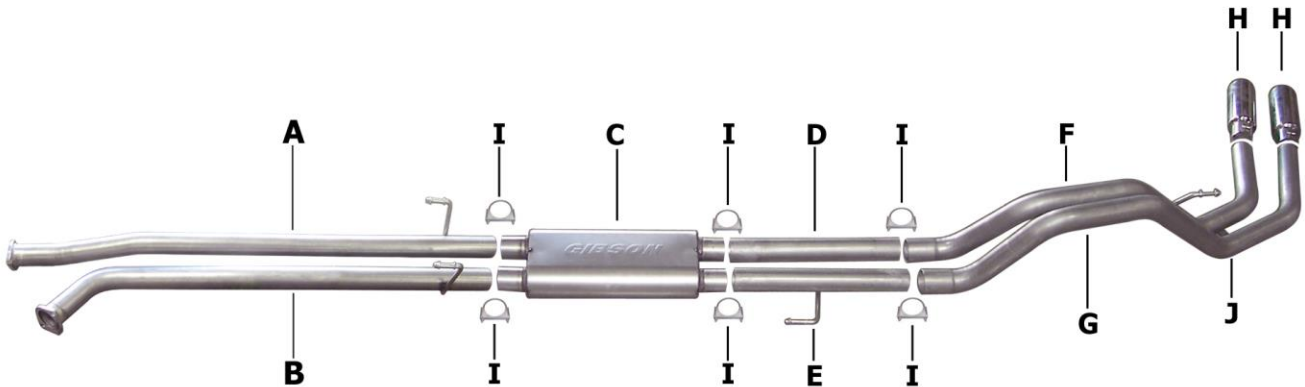

ITEM	PART	QUANTITY	DESCRIPTION
A	1214-700969S	1	2.5" Stainless Passenger Side Headpipe
B	1215-700970S	1	2.5" Stainless Driver Side Headpipe
C	11240S	1	Stainless Superflow CFT Muffler
D	1150-700909S	1	2.5" Stainless Passenger Side Extension Pipe
E	1151-700910S	1	2.5" Stainless Driver Side Extension Pipe
F	1152-700911S	1	2.5" Stainless Passenger Side Overaxle Pipe
G	1153-700912S	1	2.5" Stainless Driver Side Overaxle Pipe
H	500640-B	2	Black Ceramic Tip
I	5757	6	2.5" Clamp
J	BO-906	1	Bolt Kit

Installation Instructions #67103B

When installing this exhaust system make sure to use proper safety precautions. Use jack stands when working under the vehicle, set parking brake, block tires and use safety glasses and gloves. Allow exhaust to cool before attempting installation. Severe injury or burns could occur if safety measures are not taken.

SUGGESTED TOOLS: 1/2", 9/16", 15mm wrenches & sockets, WD-40, hacksaw, jack stands

1. Disconnect the negative battery cable before removal of OEM exhaust. This will allow the computer to reset and recognize the new exhaust. Lay out the exhaust on the floor so it looks like the drawing and compare parts with manual.



2. Remove the stock exhaust at the 2-bolt flange located in front of the muffler. Disengage the welded hangers from the OEM rubber grommets. Use WD-40 to help in the process. Do not damage or remove the rubber grommets as you will reuse them to mount your new system. Now, unbolt the tailpipe and remove exhaust. Do not throw away stock flange bolts, as you will reuse them.

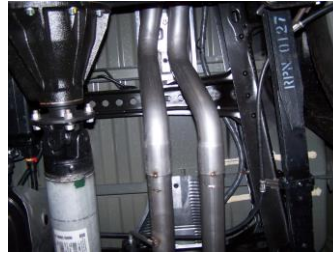

6. Install the passenger side over axle tailpipe #F to the extension pipe 1.5"-2". Using clamp #I to secure pipes together. Do not tighten. Insert welded hanger into rubber grommet.



3. Install passenger side headpipe #A using your stock bolts. Do not tighten. Next, install driver side headpipe #B using stock bolts. Do not tighten. Install metal hangers into rubber grommets.



7. Install driver side over axle tailpipe #G onto extension pipe. Use clamp #I to secure the pipe. Do not tighten.



4. Install muffer #C onto headpipes 1.5"-2" with the louvers facing towards the converter. Use a jack stand to support the muffer. Use clamps #I to secure the muffer to the headpipes. Do not tighten. Muffer inlet is looking into the louvers.



8. Use bolt kit #J to secure tabs. Make sure driver side tab is on the bottom. (You may need to loosen up the spare tire and move it over for better clearance.)



5. Install extension pipe #D into muffer. Use clamp #I to secure. Do not tighten. Next install driver side extension pipe #E into muffer using clamp #I to secure. Do not tighten. Insert welded hanger into rubber grommet.



9. Install stainless steel tips. Clamp down. When you have everything in place, firmly tighten all bolts and clamps down securely. Use stainless steel cleaner and a Scotch Brite pad weekly to prevent tip from discoloration. Inspect all fasteners after 25-50 miles of operation and re-tighten as necessary.



GIBSON EXHAUST systems are designed on a factory stock vehicle. Any aftermarket products installed could increase the sound levels of the exhaust. **Make sure there is a 1" clearance from ALL rubber brake lines, shock boots, lines, tires, etc. to prevent heat related damage or fire.**

Gibson provides the best performance exhaust systems.