

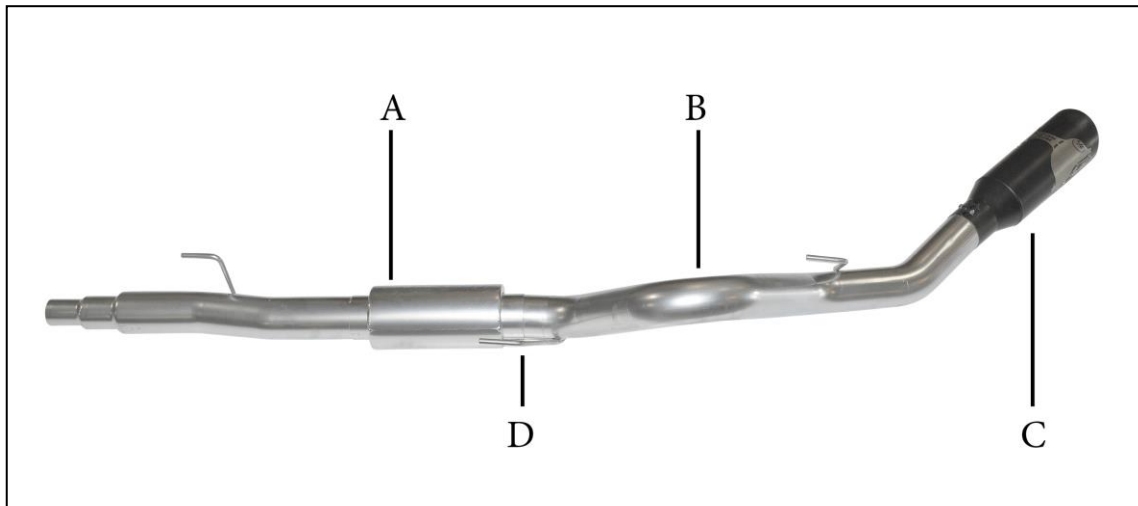

INSTALLATION INSTRUCTIONS

Patriot Skull Stainless Steel Exhaust
2009-2010 Ford F-150 4.2L, 4.6L, 5.4L
Super Crew, Super Cab, Standard Cab – Short & Long Bed
PART #76-0010



| ITEM | PART # | QTY | DESCRIPTION |
|------|-----------|-----|------------------------------|
| A | MM019 | 1 | 4.0" Muffler Assembly |
| B | MM018 | 1 | 4.0" Overaxle Pipe |
| C | 77-1036-B | 1 | 6" Patriot Skull Exhaust Tip |
| D | 5759 | 1 | 4" Band Clamp |
| | | | |

Note: This exhaust will exceed some state sound laws and requirements. Aggressive driving will get you noticed and can result in a ticket or warning from your local law enforcement agency.

EXHAUST INSTALLATION

PART# 76-0010

WHEN INSTALLING THIS EXHAUST SYSTEM MAKE SURE TO USE ALL THE PROPER SAFETY PRECAUTIONS. USE JACK STANDS WHEN UNDER TRUCK, SET PARKING BRAKE, BLOCK TIRES AND USE SAFETY GLASSES.

DO NOT WORK WITH HOT PIPES!!!

1. Disconnect the negative battery cable before removal of the OEM Exhaust. This will allow the computer to reset and recognize the new exhaust. Lay out the exhaust on the floor so it looks like the drawing and compare parts with manual. Remove the factory exhaust by cutting behind the factory muffler. Once the tail pipe has been removed un-bolt the muffler and head pipe at the clamp located in front of the factory muffler. Use wd-40 or another type of penetrating oil to remove the rubber grommets. Do not damage these they will be re used.

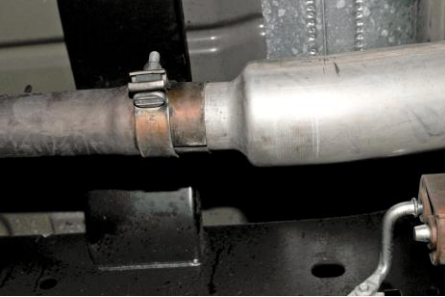

2. Install muffler assembly Item # A into the factory head pipe. You will re use the factory clamp at this connection. Install hanger into rubber grommet and loosely tighten down the clamp.

3. With the muffler assembly installed you may want to use a jack stand to support the muffler while installing the over axle pipe.

4. Install over axle pipe Item # B into the muffler outlet. Slip the hangers into the rubber grommets and keep tailpipe loose.



5. With everything loose you may need to adjust the system for proper clearance of shocks, brake lines, ect.

6. With proper clearance from spare tire install the exhaust tip onto the tailpipe. The system was designed to have the tip 1" below the quarter panel of the vehicle. With the tip in your desired position begin to tighten down all clamp connections from the front head pipe back.

7. Be sure to check all clearance after each section has been tightened to be sure there is proper clearance. It may take 4-500 miles for your vehicle to fully adjust to the changes in exhaust flow.

"MAKE SURE YOU HAVE A 1" CLEARANCE ON ALL PIPES FROM ALL RUBBER BRAKE LINES, SHOCK BOOTS, TIRES, ETC..." TORQUE ALL CLAMPS TO APPROX. 100 TO 150 FT LBS.

Looking for dependable performance exhaust systems? Rely on Gibson for quality and long-lasting products.