

BRACKET	OVAL SIDE BAR WIDESIDER 4"	WHEEL TO WHEEL WIDESIDER 4"	RUNNING BOARD WIDESIDER 5" & 6"	APPLICATION	MODEL
391235 684097B	-	394323	-	DODGE RAM 1500 / 2500 / 3500 QUAD CAB. 6.5'	02 - 08
	394123	-	39087	DODGE RAM 1500 / 2500 / 3500 QUAD CAB.	02 - 08
	64097	-	39087	DODGE RAM 1500 / 2500 / 3500 QUAD CAB.	02 - 08

Parts List:

ITEM	QTY.	CODE	DESCRIPTION	TORQUE
1	3	391234BB	Main bracket set	-
2	1	471232AA	Front auxiliary bracket set	-
3	1	391232B	Middle auxiliary bracket set	-
4	1	471232BA	Rear auxiliary bracket set	-
5	10	370200AA	3/8" bolt plate	30 Lb/Ft
KTE-391235 Hardware kit including:				
6	12	-	5/16" Box head bolt	11 Lb/t
7	12	-	5/16" Flat washer	-
8	12	-	5/16" Lock washer	-
9	12	-	5/16" Hex nut	11 Lb/t
10	6	-	3/8 x 1 1/4" Carriage head bolt	30 Lb/Ft
11	16	-	3/8" Flat washer	-
12	16	-	3/8" Lock washer	-
13	16	-	3/8" Hex nut	30 Lb/Ft
14	6	-	Vinyl gasket	-
NOTE: 394123(9-8-6-0) - 394323(6-9) / 64097(B-C-PS-BS) INCLUDES:				
15	1	-	Oval 4" Widesider bar set	-

Tools required not including:

DESCRIPTION	QTY
Socket hex 19mm -9/16" - 1/2"	1
17mm Double hex socket (12 point) or 15mm Wrench	1
Ratchet	1
Extension ratchet	1

ILLUSTRATION 1.

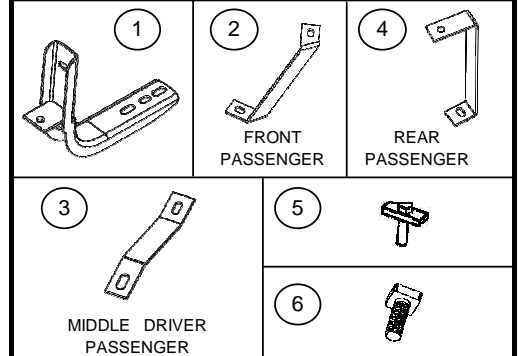

Approximated installation time: 30 min.

Instructions:

1. Before beginning the installation read all instructions thoroughly and verify that all hardware is accounted for. if there are any listed parts missing, please notify your distributor immediately.

ILLUSTRATION 2.

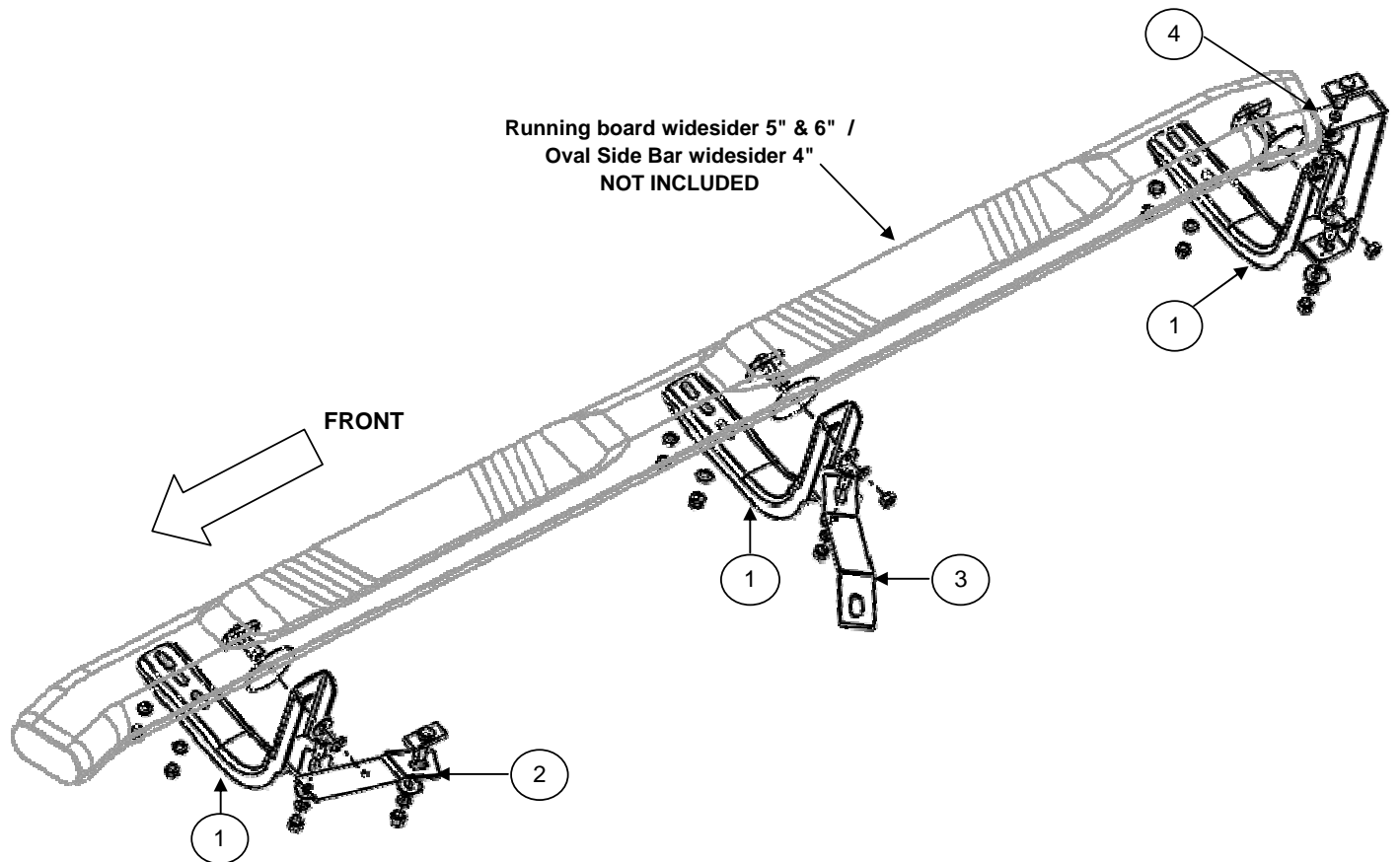

Illustration passenger side.

Cleaning and care instructions:

Protect the finish with a non-abrasive automotive wax, (e.g. Pure Carnauba) on a regular basis. The use of any soap, polish, or wax that contains an abrasive is detrimental to the finish, as the compounds scratch the finish and cause corrosion.

Design:

Quality:

INSTALLATION INSTRUCTIONS

2. To install front, middle & rear mounting brackets locate in the rocker panel the holes covered in tape and remove the tape. Place (1) vinyl gasket to the bolt of the "T" plate then insert into the exposed hole. **SEE PICTURE 1.**

PICTURE 1.

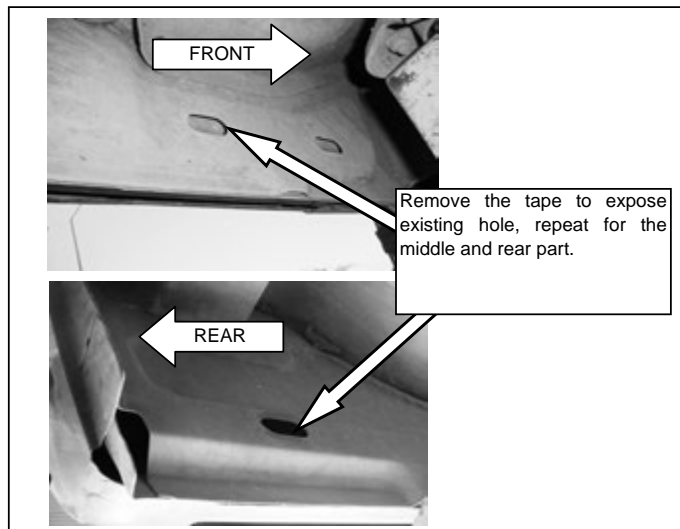

NOTE 1: It is important to place vinyl gaskets to the bolts to prevent the 3/8" bolt plate from falling into the rocker panel. **SEE PICTURE 2.**

PICTURE 2.

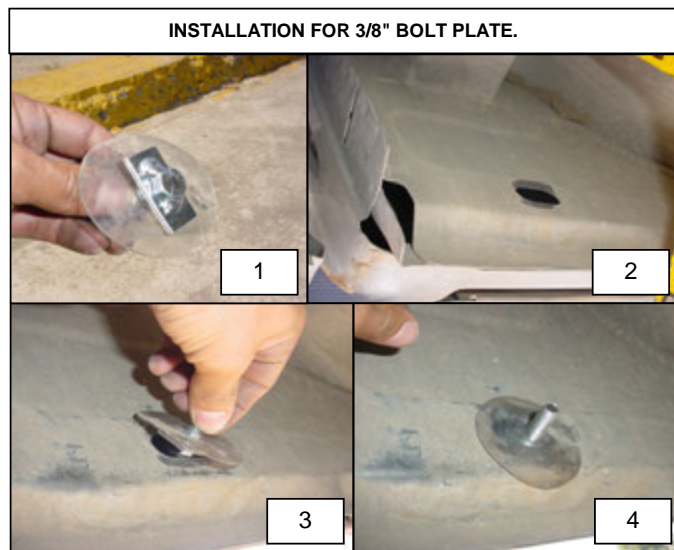

3. Place (1) front mounting bracket attach to the 3/8" bolt plate previously placed using: 3/8" flat and lock washers and 3/8" hex nut. Leave loose.

4. To install auxiliary front mounting bracket, locate existing hole next to the cab's mounting support then insert through the hole 3/8" bolt plate. Place auxiliary front mounting bracket and secure to the 3/8" bolt plate using: 3/8" flat and lock washers and 3/8" hex nut. Secure the other end to front mounting bracket using 3/8 x 1" carriage head bolt, 3/8" flat and lock washers and 3/8" hex nut. **SEE ILLUSTRATION 3.** Leave loose.

ILLUSTRATION 3.

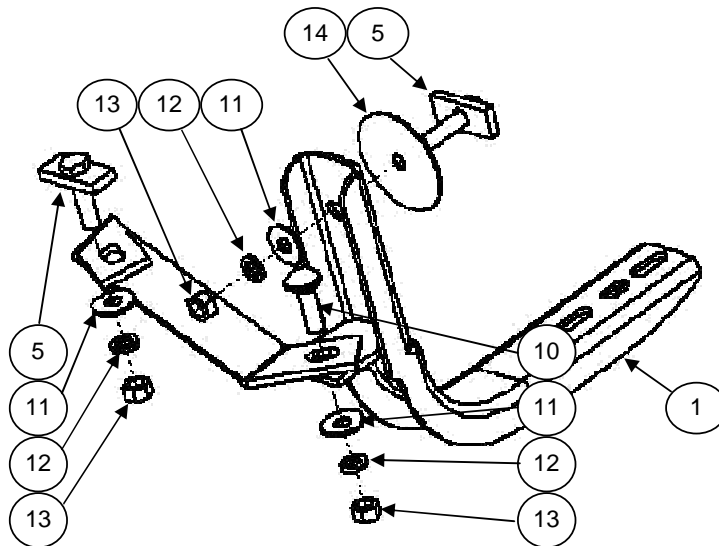

Use ratchet & 9/16" hex socket.

5. Place (1) middle mounting bracket attach to the 3/8" bolt plate previously placed using: 3/8" flat and lock washers and 3/8" hex nut. Leave loose.

6. Remove the support of the body mount, located in a flank of the frame, middle part, identify and you mount auxiliary brackets and attach with bolts before removed. Secure the other end to middle mounting bracket using 3/8 x 1" carriage head bolt, 3/8" flat and lock washers and 3/8" hex nut. **SEE ILLUSTRATION 4.** Leave loose.

ILLUSTRATION 4.

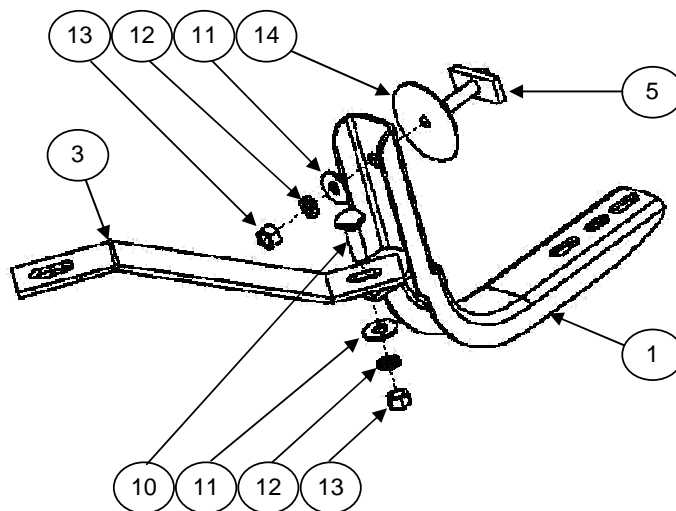

Use ratchet & 19mm - 9/16" hex socket.
Remove the bolt OEM with: ratchet & 19mm hex socket.

Cleaning and care instructions:

Protect the finish with a non-abrasive automotive wax, (e.g. Pure Carnauba) on a regular basis. The use of any soap, polish, or wax that contains an abrasive is detrimental to the finish, as the compounds scratch the finish and cause corrosion.

Design:

Quality:

INSTALLATION INSTRUCTIONS

7. Place (1) rear mounting bracket attach to the 3/8" bolt plate previously placed using: 3/8" flat and lock washers and 3/8" hex nut. Leave loose.

8. To install auxiliary rear mounting bracket, locate existing hole next to cab's support. **SEE PICTURE 1.** Introduce (1) 3/8" bolt plate then place rear auxiliary mounting bracket and secure to the bolt previously placed using 3/8" flat and lock washers and 3/8" hex nut. Secure the other end to the rear mounting bracket using 3/8 x 1" carriage head bolt, 3/8" flat and lock washers and 3/8" hex nut. **SEE ILLUSTRATION 5.** Leave loose.

10. If you acquired a Oval side bar widesider 4", place on brackets and attach with: 5/16" square head bolt, 5/16" Flat and lock washer. **SEE ILLUSTRATION 7.** Repeat for the opposite side. Leave loose.

11. Align Running board widesider 5" & 6" or Oval side bar widesider 4" and then tighten all bolts.

12. Periodically check your product because it may need a re-tighten of bolts.

13. Fill the warranty card and place it inside your vehicle's glove box.

ILLUSTRATION 5.

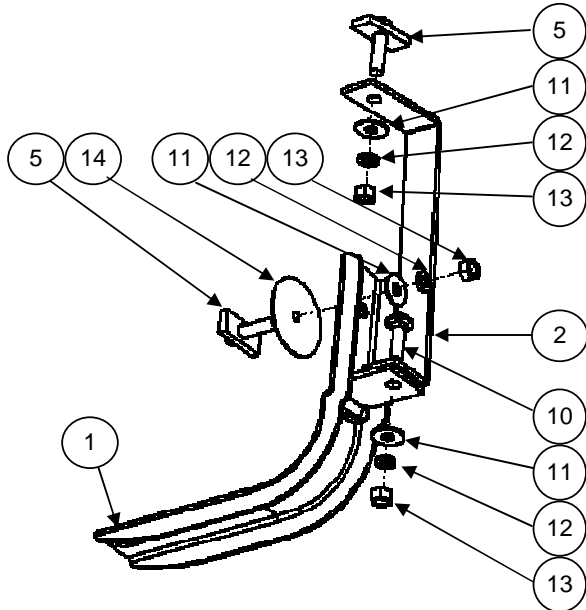

Use ratchet & 9/16" hex socket.

9. If you acquired a Running board widesider 5" & 6", insert 5/16" square head bolt on rail, place on brackets and attach with: 5/16" Flat and lock washer, 5/16" hex nut. **SEE ILLUSTRATION 6.** Repeat for the opposite side. Leave loose.

ILLUSTRATION 6

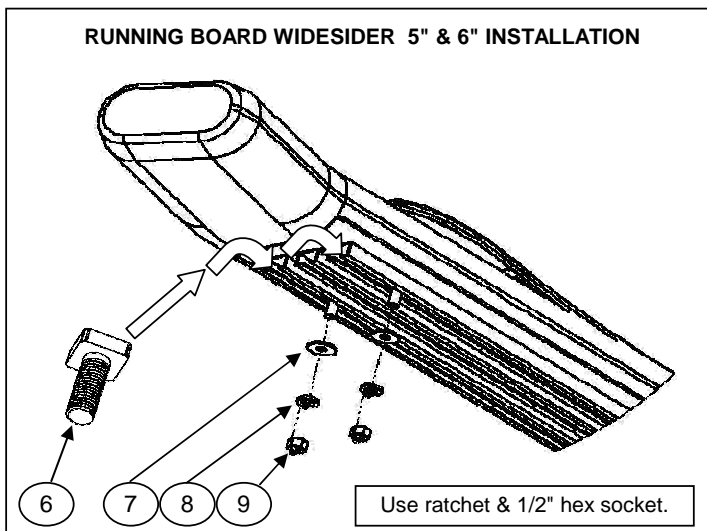
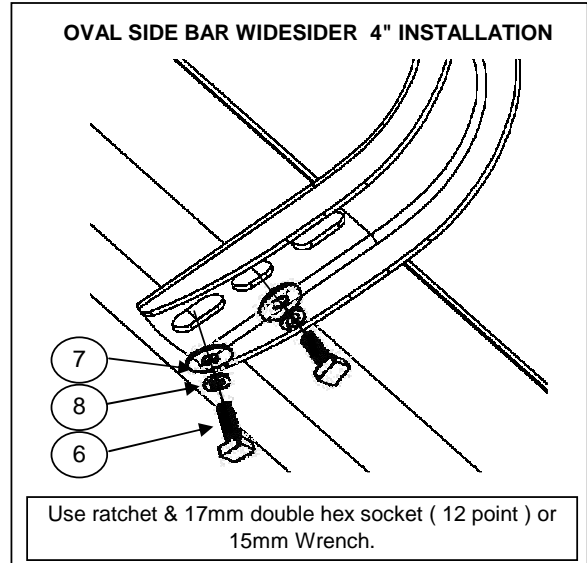

ILLUSTRATION 7



Cleaning and care instructions:

Protect the finish with a non-abrasive automotive wax, (e.g. Pure Carnauba) on a regular basis. The use of any soap, polish, or wax that contains an abrasive is detrimental to the finish, as the compounds scratch the finish and cause corrosion.

Design:

Quality:

Looking for dependable running boards & step bars?
Rely on Go Rhino for quality and long-lasting products.