

INSTALLATION INSTRUCTIONS

BRACKET	OVAL SIDE BAR WIDESIDER 4"	WHEEL TO WHEEL WIDESIDER 4"	RUNNING BOARD WIDESIDER 5" & 6"	VEHICLE	YEAR
6844155	64416(PS-SB) 64415(PS-SB)	- -	680087(B-C) 680087(B-C)	TOYOTA TUNDRA DOUBLE CAB TOYOTA TUNDRA CREW MAX	07-13 07-13

PARTS LIST:

ITEM	QTY.	DESCRIPTION	MAX TORQ.
1	1	3912896AA FRONT DRIVER AND PASSENGER BRACKET	
2	2	3912896BA MID AND REAR DRIVER AND PASSENGER BRACKET	
KTE-392895 HARDWARE KIT			
3	12	- 5/16X15/16" BLACK SQUARE HEAD BOLT	11LB/FT.
4	12	- 5/16" BLACK NUT	11LB/FT.
5	12	- 5/16" BLACK FLAT WASHER	-
6	12	- 5/16" BLACK LOCK WASHER	-
7	12	- M8X25 ZINC PLATE HEX HEAD BOLT	11LB/FT.
8	12	- 5/16" ZINC PLATE FLAT WASHER	-
9	12	- 5/16" ZINC PLATE LOCK WASHER	-
10	1	NOTE: 394185 (9-66)/ 394090 (9-66) INCLUDES: OVAL 4" WIDESIDER BAR SET	-

TOOLS REQUIRED, NOT INCLUDED:

DESCRIPTION	QTY.
RATCHET	1
12 mm SOCKET	1
13 mm SOCKET	1
5" EXTENSION RATCHET	1
15mm WRENCH	1

Pict. 1

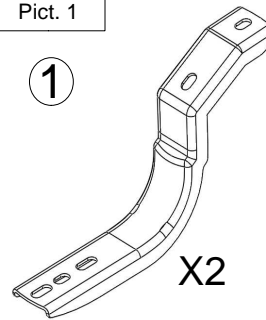

FRONT DRIVER AND PASSENGER BRACKET

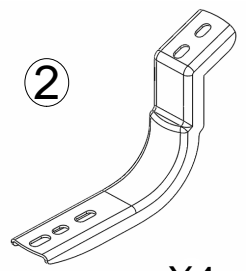

MID AND REAR, DRIVER AND PASSENGER BRACKET

APPROXIMATED INSTALLATION TIME: 30 MIN.

Pict. 2

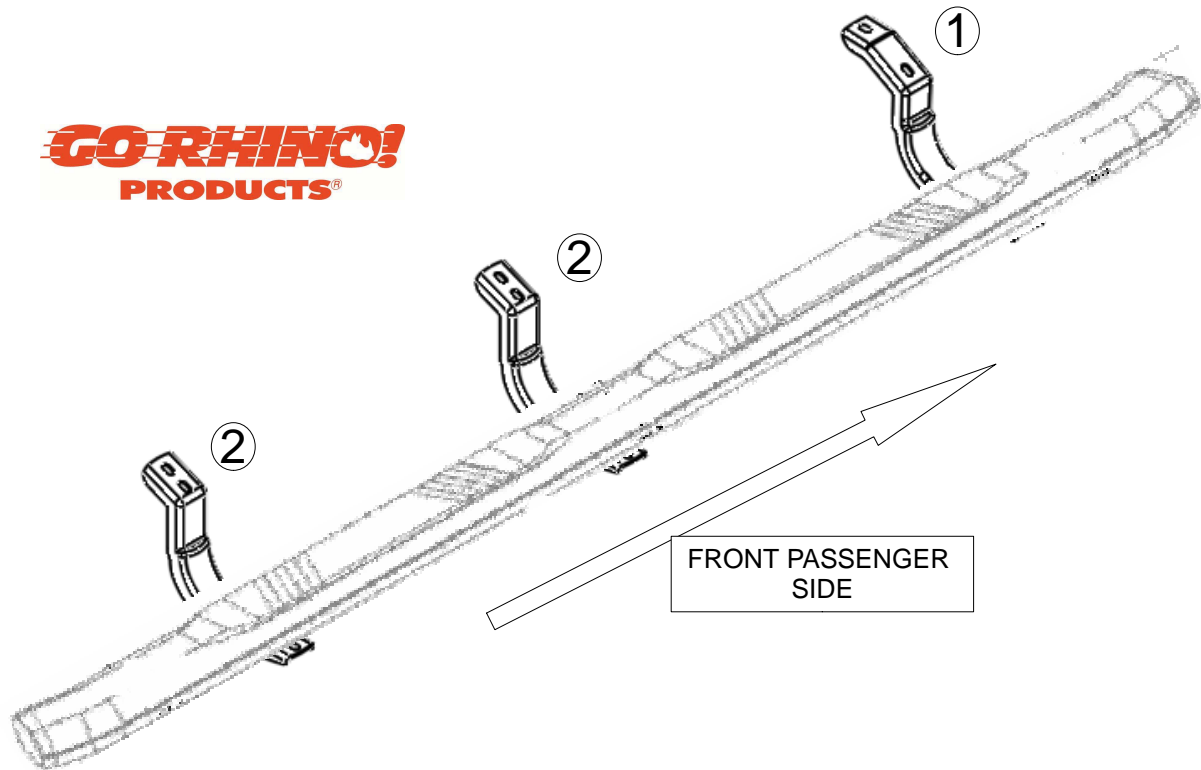

INSTALLATION INSTRUCTIONS

1. Before beginning the installation read all instructions carefully and verify that all the hardware is accounted for. If there are any listed part missing please notify your distributor immediately.
2. See pictures 3, 3a y 3b and locate the holes where the brackets are going to be installed.

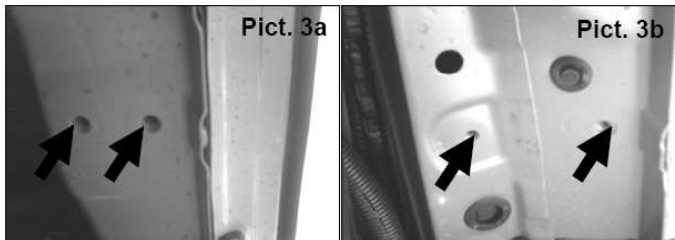
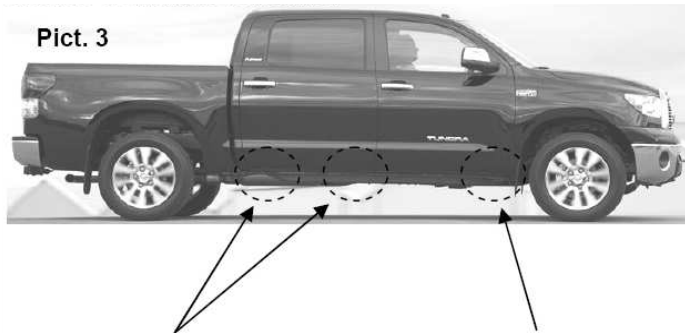

3. For the front bracket install two M8x25 hex head galvanized bolts, two flat washers and two lock washers. See picture 4 and repeat it in the opposite side of the vehicle. Leave loose.

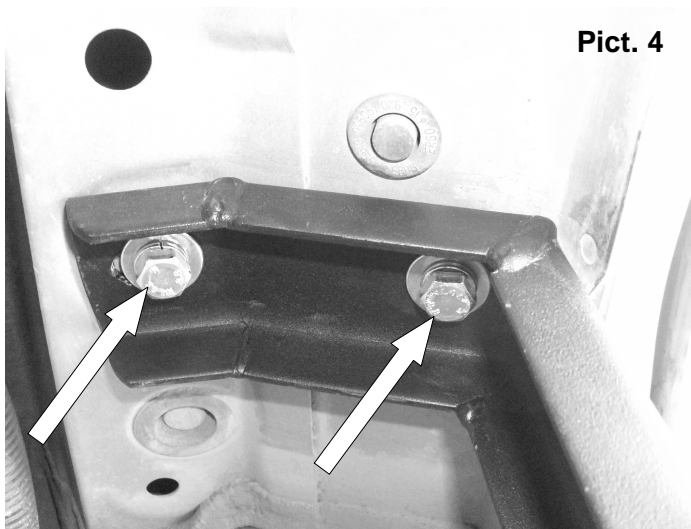

4. To install middle and rear brackets use two M8x30 hex head galvanized bolts, two flat washers and two lock washers for each bracket see picture 5 and repeat it in the opposite side. Leave loose.



5. Now proceed to install the running board sidebar (sold separately).
6. To install the running board, insert three square head bolts per each channel that it's located on the bottom (discard middle channel) refer picture 6.

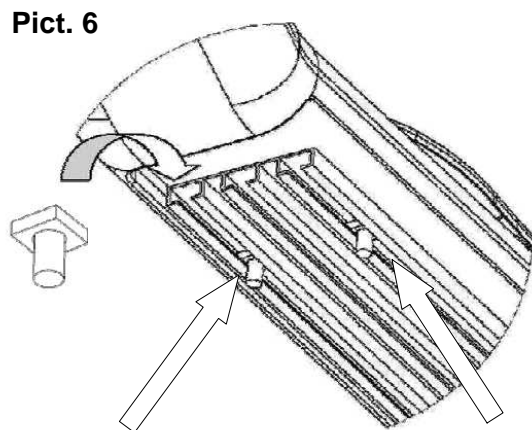

INSTALLATION INSTRUCTIONS

7. Place the running board above the brackets attach it with six 5/16" nuts, six flat washers and six lock washers per side. (hardware in black galvanized finish). See picture 7 and repeat in the opposite side. Leave loose.



8. If you are going to install an oval sidebar use two flat washers, two lock washers and two 5/16" nuts per bracket (hardware in black galvanized finish). See picture 8 and repeat in the opposite side. Leave loose.

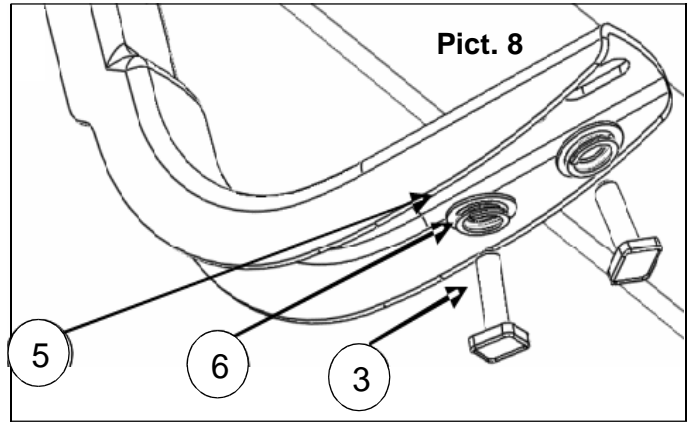

9. Align sidebar and then tighten all bolts.
10. Do not use abrasive substances to clean your product.
11. Periodically check your product because it may need a re-tighten of bolts.
12. Fill the warranty card and place it inside your vehicle's glove box.

INSTALLATION INSTRUCTIONS

UNIVERSAL RUNNING BOARD

Parts List				
Item	Qty.	Code	Description	Max. Torque
1	1 Set	-	Running Board	-
2	6 Pc.	396804AA	U (Clamp) Bracket *	-

* Wheel to Wheel Running Boards have the U (Clamp) Brackets included on the Bracket Kit (Sold Separately)

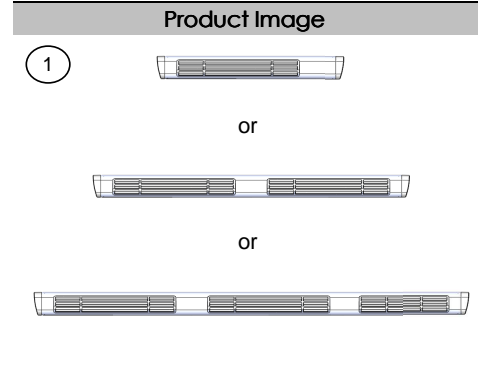

Required Tools (Not included)

Qty.	Description
1	15mm Wrench
1	17mm Socket
1	Ratchet

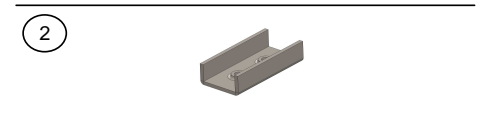

Instructions

1. Before beginning the installation, please read all directions carefully and verify that all necessary hardware is accounted for. If any parts are missing, stop the installation and contact your distributor immediately.
2. To maintain and care this product keep it clean and do not use abrasive cleaners or polish waxes. We recommend to use only non-abrasive automotive wax such as pure carnauba to avoid scratches and rust.
3. Once the main brackets are installed (**sold separately**), the approximate installation time is **15 min.**
4. Place the U brackets inside the Running Board. Move them to align to the main brackets. **See illustration 1.**
5. Place the flat and lock washers with the square head bolts. This hardware kit is included on the main brackets that are (**sold separately**). **See illustration 1.**
6. Align the Running board and tighten the bolts using a 1/2" wrench.
7. **NOTE: For some regular cabs only two U brackets are needed per side.**

ILLUSTRATION 1.

