

INSTALLATION INSTRUCTIONS

UNIVERSAL RUNNING BOARD

Parts List				
Item	Qty.	Code	Description	Max. Torque
1	1 Set	-	Running Board	-
2	6 Pc.	396804AA	U (Clamp) Bracket *	-

* Wheel to Wheel Running Boards have the U (Clamp) Brackets included on the Bracket Kit (Sold Separately)

Required Tools (Not included)	
Qty.	Description
1	15mm Wrench
1	17mm Socket
1	Ratchet

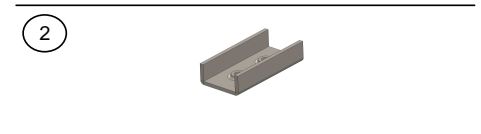
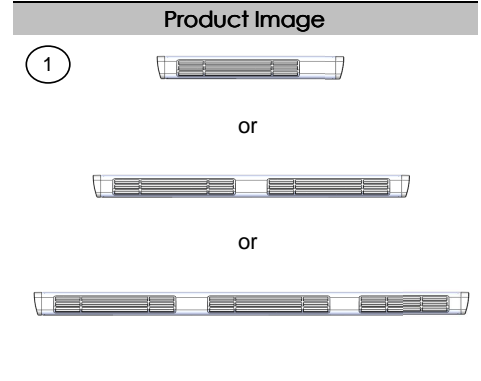

Instructions

1. Before beginning the installation, please read all directions carefully and verify that all necessary hardware is accounted for. If any parts are missing, stop the installation and contact your distributor immediately.
2. To maintain and care this product keep it clean and do not use abrasive cleaners or polish waxes. We recommend to use only non-abrasive automotive wax such as pure carnauba to avoid scratches and rust.
3. Once the main brackets are installed (**sold separately**), the approximate installation time is **15 min.**
4. Place the U brackets inside the Running Board. Move them to align to the main brackets. **See illustration 1.**
5. Place the flat and lock washers with the square head bolts. This hardware kit is included on the main brackets that are (**sold separately**). **See illustration 1.**
6. Align the Running board and tighten the bolts using a 1/2" wrench.
7. **NOTE: For some regular cabs only two U brackets are needed per side.**

ILLUSTRATION 1.

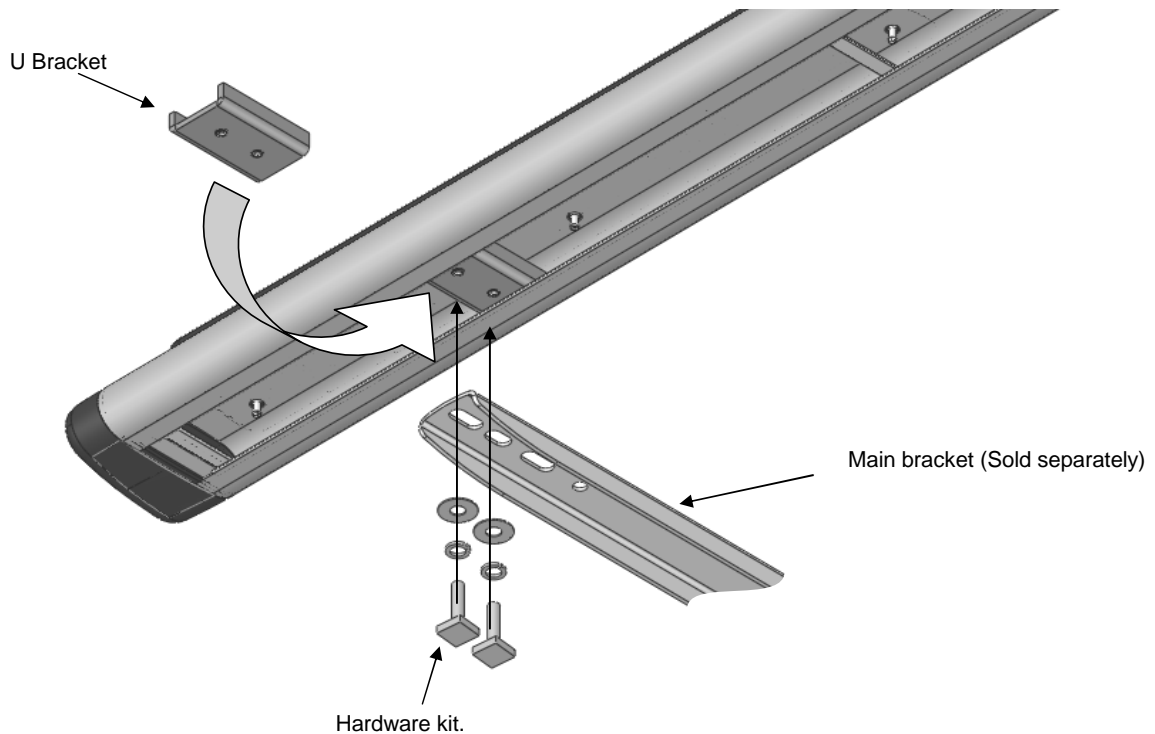

INSTALLATION INSTRUCTIONS

BRACKET	OVAL SIDE BAR WIDESIDER 4"	WHEEL TO WHEEL WIDESIDER 4"	RUNNING BOARD WIDESIDER 5" & 6"	APPLICATION	MODEL
6841805	64180 67180	-	39587 39687	FORD SUPER DUTY CREW CAB.	99 - 13
	64176 67176	-	39587 39687	FORD SUPER DUTY EXT. CAB.	99 - 13
	-	641262	-	FORD SUPER DUTY CREW CAB. 6'	99 - 13
	-	641256	-	FORD SUPER DUTY EXT. CAB. 6'	99 - 13

Parts List:

ITEM	QTY	CODE	DESCRIPTION	MAX. TORQUE
1	3	3910306AB	Brackets set (Front & Middle & Rear)	-
		KTE-390305	Hardware kit includes:	
2	12	-	5/16" Box head bolt	11 lb.ft
3	12	-	5/16" Flat washer	-
4	12	-	5/16" Lock washer	-
5	12	-	5/16" Hex nut	11 lb.ft
6	12	-	3/8 x 1 1/4" Hex head bolt	30 lb.ft
7	18	-	3/8" Flat washer	-
8	12	-	3/8" Lock washer	-
9	6	-	3/8" Hex nut	30 lb.ft
10	6	-	3/8" Clip nut	30 lb.ft
11	1	-	Oval side bar widesider 4"	-

Tools required not including:

DESCRIPTION	QTY
9/16" & 1/2" Hex socket / 9/16" Wrench	1
17mm Double hex socket (12 point) or 15mm Wrench	1
Ratchet	1
Ratchet extension	1

ILLUSTRATION 1

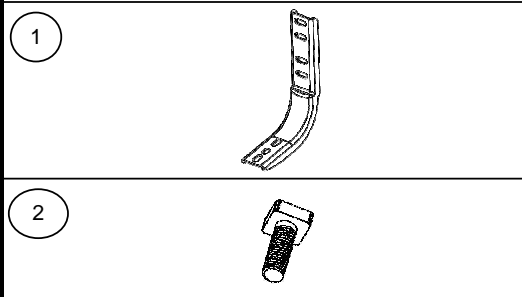

Approximated installation time: 30 min.

Instructions:

1. Before beginning the installation read all instructions thoroughly and verify that all hardware is accounted for. if there are any listed parts missing, please notify your distributor immediately.

ILLUSTRATION 2

Running board widesider 5" & 6" /
Oval Side Bar widesider 4"
NOT INCLUDED

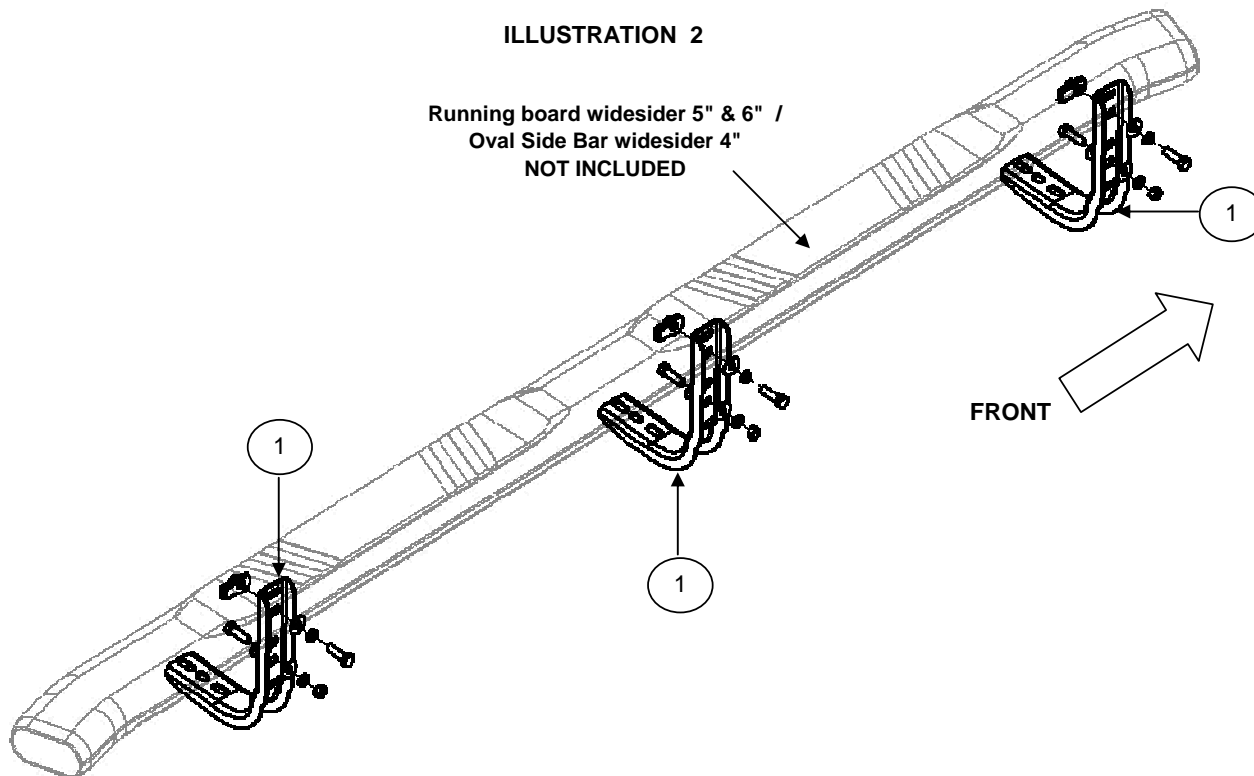

Illustration driver side.

Cleaning and care instructions:

Protect the finish with a non-abrasive automotive wax, (e.g. Pure Carnauba) on a regular basis. The use of any soap, polish, or wax that contains an abrasive is detrimental to the finish, as the compounds scratch the finish and cause corrosion.

INSTALLATION INSTRUCTIONS

2. Located holes inside the body in vehicle, front, middle, rear, place a clip nut in upper part. **SEE ILLUSTRATION 3.**

ILLUSTRATION 3

To install the brackets in rocker panel.

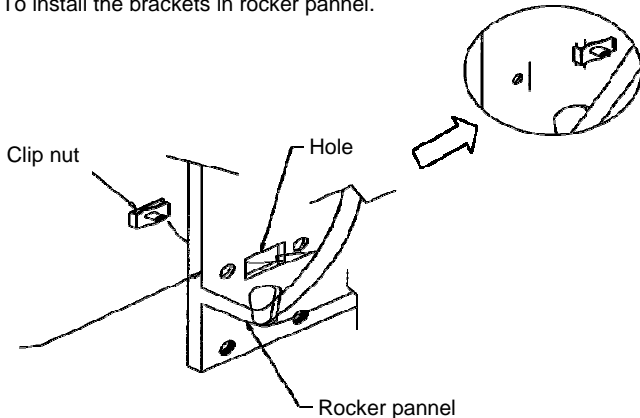

3. Mount bracket and attach with: (1) 3/8 x 1 1/4" hex head bolt, (1) 3/8" flat and lock washers, in lower part attach with: (1) 3/8 x 1 1/4" hex head bolt, (2) 3/8 flat washer, (1) 3/8" lock washer, (1) 3/8" hex nut. **SEE ILLUSTRATION 4.** By each bracket. Leave loose.

ILLUSTRATION 4

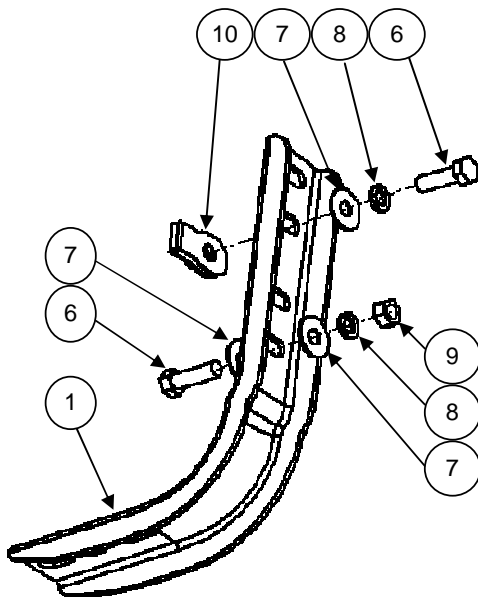

Use ratchet & 9/16" hex socket & 9/16" wrench.

Illustration to front, middle and rear part. Driver side.

4. If you acquired a Running board widesider 5" & 6", insert 5/16" square head bolt on rail, place on brackets and attach with: 5/16" Flat and lock washer, 5/16" hex nut. **SEE ILLUSTRATION 5.** Repeat for the opposite side. Leave loose.

ILLUSTRACION 5

RUNNING BOARD WIDESIDER 5" & 6" INSTALLATION

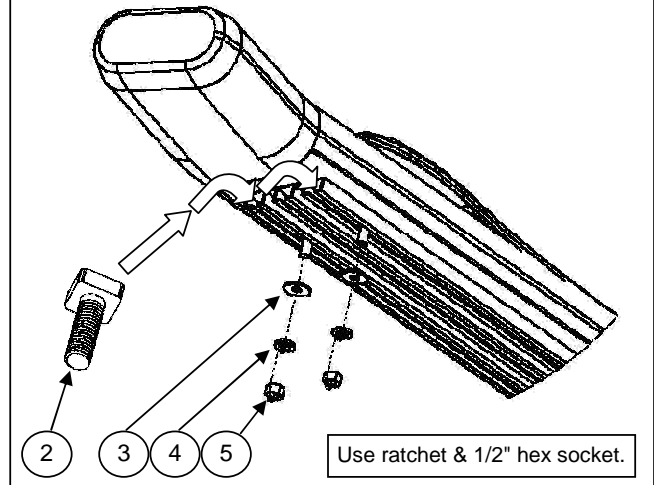

5. If you acquired a Oval side bar widesider 4", place on brackets and attach with: 5/16" square head bolt, 5/16" Flat and lock washer. **SEE ILLUSTRATION 6.** Repeat for the opposite side. Leave loose.
 6. Align Running board widesider 5" & 6" or Oval side bar widesider 4" and then tighten all bolts.
 7. Periodically check your product because it may need a re-tighten of bolts.
 8. Fill the warranty card and place it inside your vehicle's glove box.

ILLUSTRACION 6

OVAL SIDE BAR WIDESIDER 4" INSTALLATION

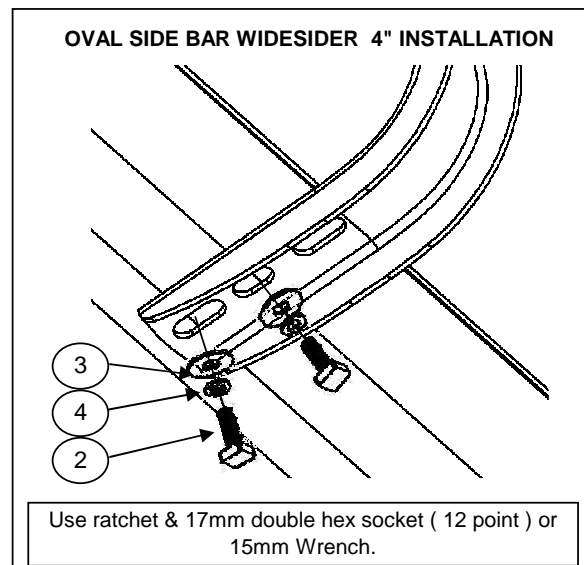

Use ratchet & 17mm double hex socket (12 point) or 15mm Wrench.

Cleaning and care instructions:

Protect the finish with a non-abrasive automotive wax, (e.g. Pure Carnauba) on a regular basis. The use of any soap, polish, or wax that contains an abrasive is detrimental to the finish, as the compounds scratch the finish and cause corrosion.