

**INSTALLATION INSTRUCTIONS**

BRACKET	OVAL SIDE BAR WIDESIDER 4"	WHEEL TO WHEEL	RUNNING BOARD WIDESIDER 5" & 6"	APPLICATION	MODEL
6843515	64351 - 67351	-	39087	NISSAN TITAN CREW CAB.	04 - 12
	64353 - 67353	-	39080	NISSAN TITAN EXT. CAB.	04 - 12

**Parts List:**

ITEM	QTY	CODE	DESCRIPTION	TORQUE MAX.
1	6	390594AA	Main brackets pc	-
<b>KTE-390595 Hardware kit including:</b>				
2	12	-	5/16" Square head bolt	11 Lb.ft
3	24	-	5/16" Flat washer	-
4	24	-	5/16" Lock washer	-
5	12	-	5/16" Hex nut	11 Lb.ft
6	6	-	M8 x 30mm Hex head bolt	11 Lb.ft
7	6	-	M8 hex nut	11 Lb.ft
<b>NOTE: 394058(9-66) / 394059(9-66) INCLUDES:</b>				
8	1	-	Oval 4" Widesider bar set	-

**Tools required not including:**

DESCRIPTION	QTY
13mm Socket / Wrench	1
Ratchet	1
Extension ratchet	1

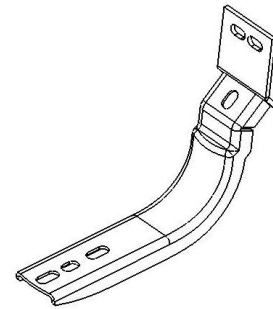

**Instructions:**

**Approximated installation time: 30 min.**

1. Before beginning the installation read all instructions thoroughly and verify that all hardware is accounted for. If there are any listed parts missing, please notify your distributor immediately.
2. Locate in the rocker panel the existing bolts and the threaded holes covered with a plastic plugs (remove the plastic plugs). See Picture 1.
3. Place mounting bracket as shown, secure to the threaded hole using (1) M8 x 30mm hex head bolt and 5/16" flat and lock washer and to the existing bolt with (1) 5/16" lock and flat washer and (1) M8 hex nut. Leave loose. See Diagram 1. Repeat the same procedure for each bracket.

**PICTURE 1**

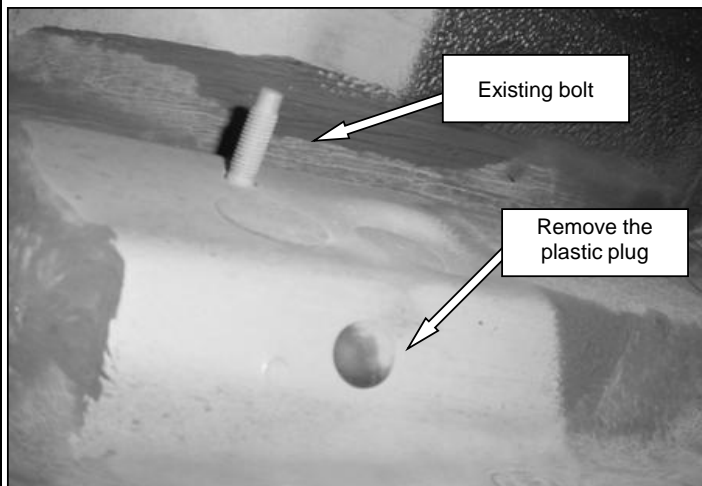

**DIAGRAM 1**

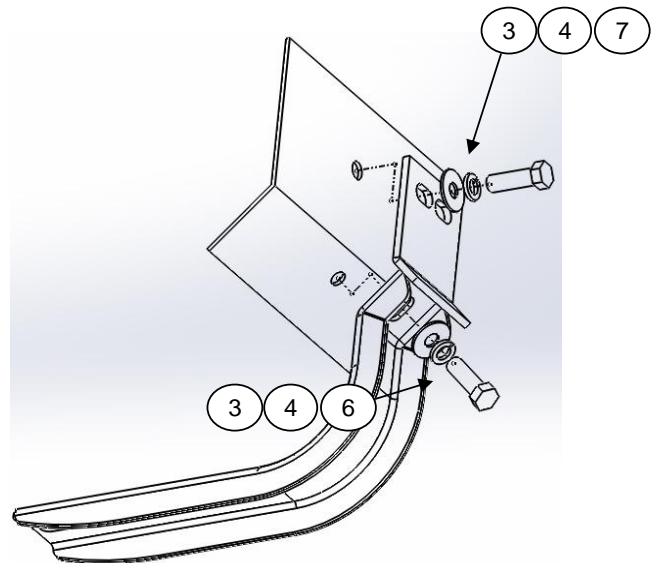

## INSTALLATION INSTRUCTIONS

4. Install Running board, first insert 5/16" square head bolt on rail, place on brackets aligns and attach with: ( 2 ) 5/16" Flat and lock washer, ( 2 ) 5/16" hex nut. **See illustration 1 or 2 depending on which product you acquired.** Repeat for each bracket. Leave loose.
5. Align, and then get tighten all bolts. Repeat the steps to install the opposite side.
6. Do not use abrasive substances to clean your product.
7. Periodically check your product because it may need a re-tighten of bolts.
8. Fill the warranty card and place it inside your vehicle's glove box.

PICTURE 2

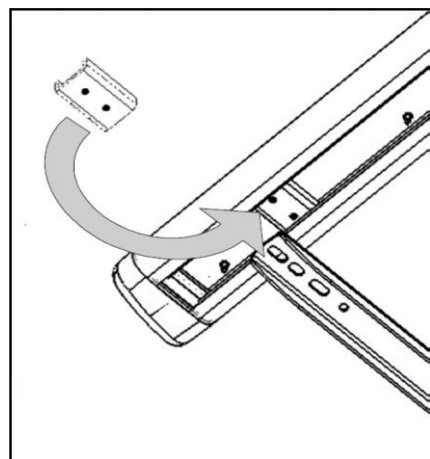
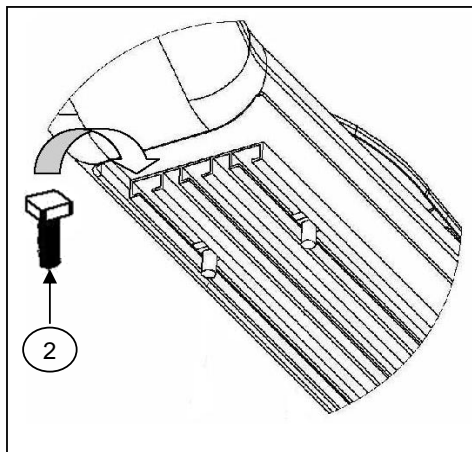
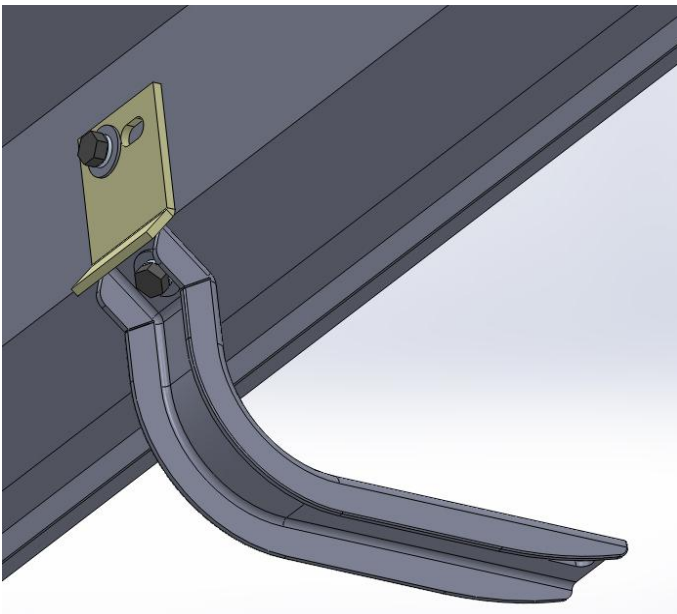

# INSTALLATION INSTRUCTIONS

## UNIVERSAL RUNNING BOARD

Parts List				
Item	Qty.	Code	Description	Max. Torque
1	1 Set	-	Running Board	-
2	6 Pc.	396804AA	U (Clamp) Bracket *	-

\* Wheel to Wheel Running Boards have the U (Clamp) Brackets included on the Bracket Kit (Sold Separately)

Required Tools (Not included)	
Qty.	Description
1	15mm Wrench
1	17mm Socket
1	Ratchet

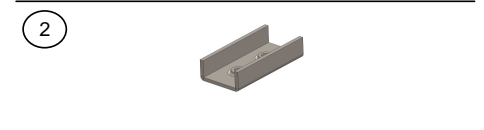
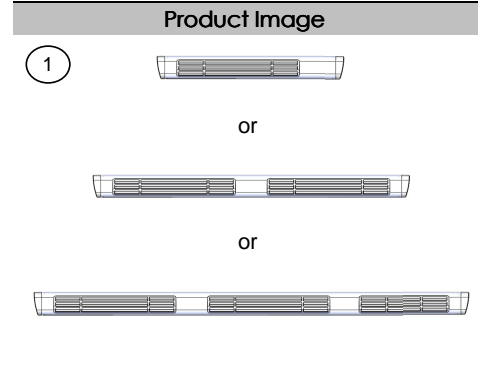

### Instructions

1. Before beginning the installation, please read all directions carefully and verify that all necessary hardware is accounted for. If any parts are missing, stop the installation and contact your distributor immediately.
2. To maintain and care this product keep it clean and do not use abrasive cleaners or polish waxes. We recommend to use only non-abrasive automotive wax such as pure carnauba to avoid scratches and rust.
3. Once the main brackets are installed **(sold separately)**, the approximate installation time is **15 min.**
4. Place the U brackets inside the Running Board. Move them to align to the main brackets. **See illustration 1.**
5. Place the flat and lock washers with the square head bolts. This hardware kit is included on the main brackets that are **(sold separately)**. **See illustration 1.**
6. Align the Running board and tighten the bolts using a 1/2" wrench.
7. **NOTE: For some regular cabs only two U brackets are needed per side.**

ILLUSTRATION 1.

