



**Installation Guide:  
LED Beacons  
Model 7781 Model 7782  
Model 7783 Model 7784**

**⚠ WARNING:** This product can expose you to chemicals including Methylene Chloride which is known to the State of California to cause cancer, and Bisphenol A, which is known to the State of California to cause birth defects or other reproductive harm.

## ***Safety First***

This document provides all the necessary information to allow your Grote® product to be properly and safely installed. Before beginning the installation and/or operation of your new product, the installation technician and operator must read this manual completely. Important information is contained herein that could prevent serious injury or damage.

- **Proper installation of this product requires the installer to have a good understanding of automotive electronics, systems and procedures.**
- **If mounting this product requires drilling holes, the installer MUST be sure that no vehicle components or other vital parts could be damaged by the drilling process. Check both sides of the mounting surface before drilling begins. Also de-burr the holes and remove any metal shards or remnants. Install grommets into all wire passage holes.**
- **If this manual states that this product may be mounted with magnets or any other temporary mounting style, clean the mounting surface with a 50/50 mix of isopropyl alcohol and water and dry thoroughly.**
- **DO NOT INSTALL THIS PRODUCT OR ROUTE ANY WIRES IN THE DEPLOYMENT AREA OF YOUR AIR BAG. EQUIPMENT MOUNTED OR LOCATED IN THE AIR BAG DEPLOYMENT AREA WILL DAMAGE OR REDUCE THE EFFECTIVENESS OF THE AIR BAG, OR BECOME A PROJECTILE THAT COULD CAUSE SERIOUS PERSONAL INJURY OR DEATH. REFER TO YOUR VEHICLE OWNERS MANUAL FOR THE AIR BAG DEPLOYMENT AREA. THE USER/INSTALLER ASSUMES FULL RESPONSIBILITY TO DETERMINE PROPER MOUNTING LOCATION, BASED ON PROVIDING ULTIMATE SAFETY TO ALL PASSENGERS INSIDE THE VEHICLE.**
- **For this product to operate at optimum efficiency, a good electrical connection to chassis ground must be made. The recommended procedure requires the product ground wire to be connected directly to the NEGATIVE (-) battery post (this does not include products that use cigar power cords).**
- **If this product uses a remote device for activation or control, make sure that this device is located in an area that allows both the vehicle and the device to be operated safely in any driving condition.**
- **Do not attempt to activate or control this device in a hazardous driving situation.**
- **This product contains either strobe light(s), halogen light(s), high-intensity LEDs or a combination of these lights. Do not stare directly into these lights. Momentary blindness and/or eye damage could result.**
- **Use only soap and water to clean the outer lens. Use of other chemicals could result in premature lens cracking (crazing) and discoloration. Lenses in this condition have significantly reduced effectiveness and should be replaced immediately. Inspect and operate this product regularly to confirm its proper operation and mounting condition. Do not use a pressure washer to clean this product.**
- **It is recommended that these instructions be stored in a safe place and referred to when performing maintenance and/or reinstallation of this product.**
- **FAILURE TO FOLLOW THESE SAFETY PRECAUTIONS AND INSTRUCTIONS COULD RESULT IN DAMAGE TO THE PRODUCT OR VEHICLE AND/OR SERIOUS INJURY TO YOU AND YOUR PASSENGERS!**

**Grote®** beacon models 7781, 7782, 7783 & 7784 feature pattern selection capabilities that allow you to choose between 15 available flash patterns. Models 7781 & 7783 feature three different mounting options: permanent mount, 1" NPT pipe mount or J-bolt mount. Models 7782 & 7784 are magnetically mounted beacons and **do not** offer pattern selection capability.

**Wiring:**

**Note: All beacons in this manual should be fused at 5 AMPS.**

**WARNING! All customer supplied wires should be sized to supply at least 125% of the maximum operating current and be fused at the battery to carry the load.**

Listed below are the wire designations. Use the recommended gauge when extending beacon wires.

WIRE COLOR	WIRE GAUGE	FUNCTION
ORANGE or WHITE	18 AWG	Positive
BLACK	18 AWG	Ground
WHITE-VIOLET	18 or 22 AWG	Pattern Selection

**Mounting:**

**1 Inch (NPT) Pipe Mount:**

Threading for a 1 inch (NPT) pipe mounting is precast in the base.

1. Feed power cable through the 1 inch pipe and connect the cable to the wires of the beacon.
2. Screw the beacon into the threads on the 1" pipe, taking precaution not to damage the connected power wires. Do not tighten base too hard as not to damage threads on base.

**Permanent Mount:**

1. Use the base as a template and mark off the three mounting holes onto the mounting surface. After removing the base, in the center between the three mounting holes, mark the location of the wire access hole.
2. Drill mounting holes into the mounting surface with a drill sized for the #10 mounting screws supplied. Drill the wire access hole using a 3/8" drill (.375 inch). Remove any burrs from the wire access hole as not to damage wires. It is also recommended that you install a rubber grommet (customer supplied) into the wire hole to further protect the wires.
3. The base seal will be used between the LED beacon base and the mounting surface.

**Mounting Plan / Permanent Mount**

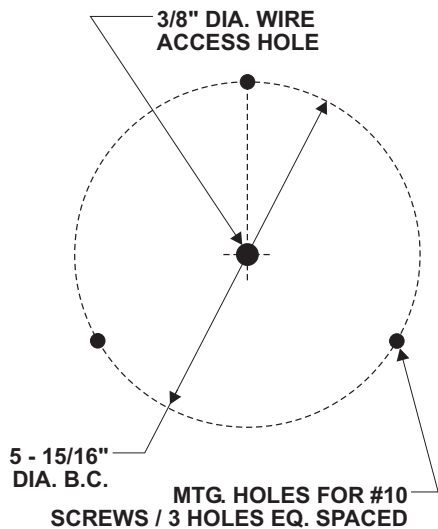

4. Feed the wires first through the base seal and then through the cable access hole and place the base (with seal) on the mounting surface (while lining up the mounting holes in the base with the mounting holes you drilled into the mounting surface). Secure the beacon firmly to the mounting surface with the supplied mounting screws (ITEM 8).

**"J" Bolt Mount:**

This beacon is equipped to handle the "J" bolt mount available on some beacons. Be sure to use the correct "J" bolt mounting holes (Fig. 1).

**Magnetic Mount:**

With the magnetic mount you will be able to mount your beacon so that you can remove it if necessary and avoid drilling. With a magnet mount equipped beacon, you just place the beacon on any metal surface, plug the cigar cord into you vehicles cigar lighter and you are ready to go.

**Note: Magnetically mounted models do not offer Pattern Selection and comes equipped with SignalAlert™75.**

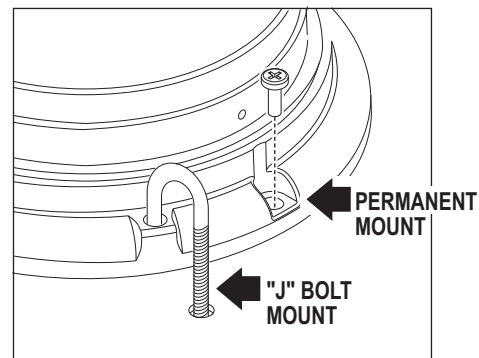

**WARNING: The use of any magnetically mounted warning beacon on the outside of a vehicle while it is in motion is not recommended and is at the sole discretion and risk of the user.**

**Programming / Pattern Selection / White-Violet:**

When the lighthouse is turned on, the default pattern is displayed.

**To advance to the next pattern:** With the lighthouse on, apply positive voltage to the WHITE-VIOLET wire for less than 1 second and release. Repeat the procedure to advance the lighthouse to the next pattern.

**To lock in a pattern:** While cycling through the patterns, let a pattern run for more than 5 seconds and it will become the default pattern.

**To cycle backwards to previous patterns:** With the lighthouse on, apply positive voltage to the WHITE-VIOLET wire for more than 1 second and release.

**To reset to the factory default pattern:** Turn off power to the beacon. Then, while applying positive voltage to the WHITE-VIOLET wire, turn the beacon back on. Continue to apply voltage to the WHITE-VIOLET wire for 5 seconds.

**Available Scan-Lock™ Patterns:**

- |                      |                          |
|----------------------|--------------------------|
| 1 - SignalAlert™ 75  | 9 - ActionFlash™         |
| 2 - SignalAlert™ 150 | 10 - ModuFlash™ 80       |
| 3 - SingleFlash 375  | 11 - ComAlert™           |
| 4 - SingleFlash 150  | 12 - ActionScan™         |
| 5 - SingleFlash 75   | 13 - SignalAlert™ Steady |
| 6 - DoubleFlash 150  | 14 - Steady-Brake        |
| 7 - DoubleFlash 75   | 15 - Steady              |
| 8 - CometFlash® 75   |                          |