

## 1937-1939 and 1940-1948 CHEVY



### IMPORTANT INFORMATION!

- 1 Read these instructions fully before starting your installation.
- 2 MEASURE TWICE, WELD ONCE!

## 1 Preparing the Frame

Support the vehicle on 4 jack stands and remove all stock components. Next, trim the stock front crossmember as shown in **Figure 1**. Trim off the flanges on the underside of the frame rails that were attached to the trimmed-off crossmember section. The knee action front crossmember should be trimmed in the same way. See **Figure 2**. For a 1940-48 Chevy, unbolt and remove the front suspension assembly (including the stock crossmember) from the frame at this time. Using the rubber snubber holes at the top of the frame as a guide, make a line mark on the frame 1/2" back. Scribe the line mark around the frame, to denote the axle centerline. See **Figure 3**. Trim off the flange on the inside of the frame rails in the area of the new crossmember as shown in **Figure 4**.

## 2 Installing the Crossmember

Trial fit the crossmember onto the rails. It should be centered on the marked axle centerline as shown in **Figure 5**. Make sure the crossmember is fully seated on the underside of the frame and not on the remaining flange of the old front crossmember section. Clamp in place and weld when the crossmember is completely square and the measurements have been double checked. Weld the sides, top and bottom to prevent unwanted flex and twist.

**Figure 1.**

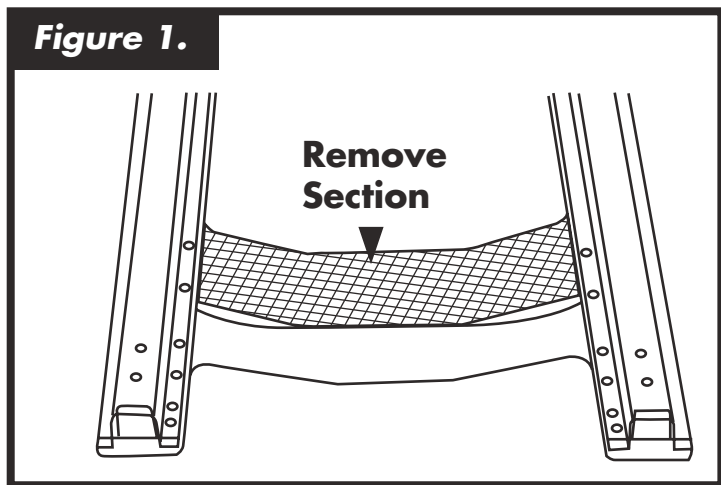

## 3 Assembling the Components

Position the upper control-arm mounts as shown in **Figure 6**. The upper mounts should line up with the main crossmember and contact the entire top of the main crossmember. Make sure the upper mounts are parallel as shown in **Figure 7**. The dimension across the upper mount tubes should be 28-1/8". Weld securely after measurements have been double-checked. Assemble all [suspension components](#) but do not install the coil-over assemblies at this time. Next, position the car at the desired finished ride angle (rake) and prop up the lower control arms so they are level. Using the adjusters in the upper control arms, adjust the caster, camber and toe-in using the following settings:

*Caster: 1° positive*

*Camber: 1/4° positive*

*Toe-In: 1/8" +/- 1/8"*

Both adjusters should be adjusted equally, as should both sides of the vehicle. 2° or 3° of caster will give better high-speed stability. Fine-tune to desired quality. Relax the suspension and install the coil-overs with the spring seats in the bottom position to provide the least amount of preload. Place the car on the ground and adjust the spring seat rings to level out the lower control arms. The vehicle should be fully weighted as finished at this point.

## 4 Final Adjustments

The vehicle should be finished and driveable. After a few hundred miles, double-check the alignment and ride height as the springs may have settled and changed the camber settings. Adjust the ride height before changing the alignment.

**Figure 2.**

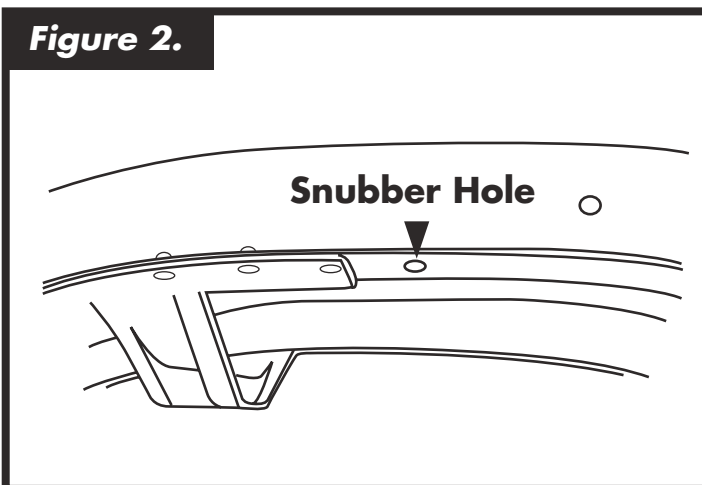

User Guide & Installation Manual  
**CORNER KILLER II IFS**

**1937-1939 and 1940-1948 CHEVY**

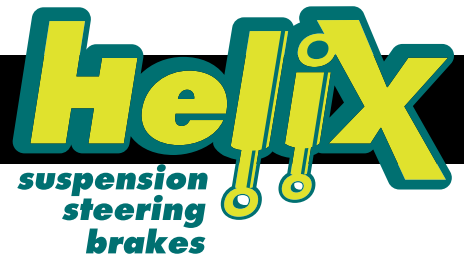

**Figure 3.**

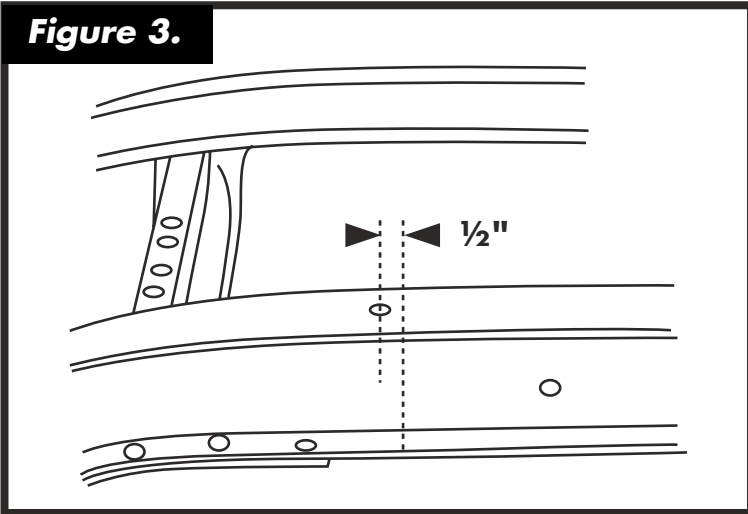

**Figure 4.**

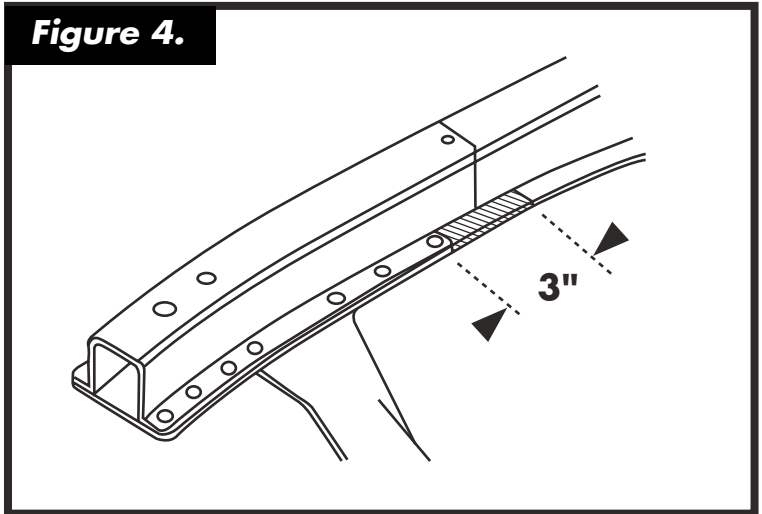

**Figure 5.**

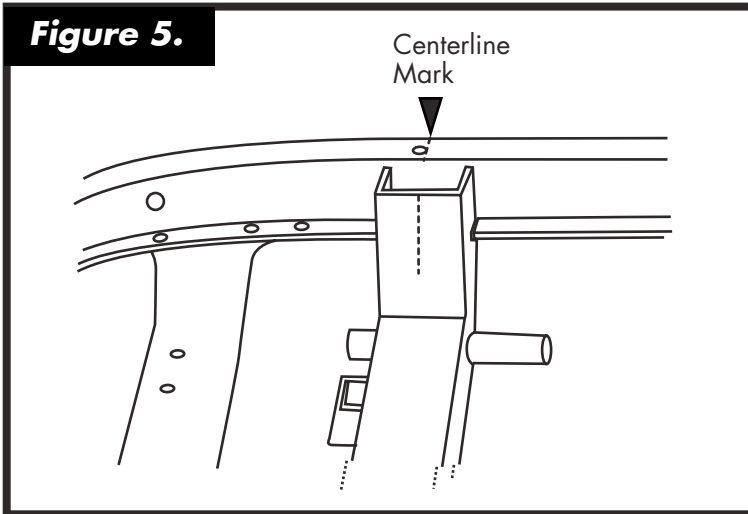

**Figure 6.**

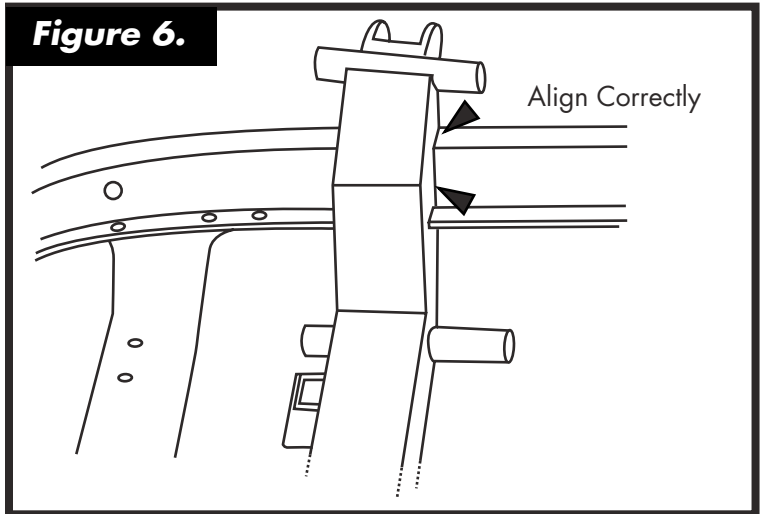

**Figure 7.**

