

Hellwig PRODUCTS

INSTALLATION INSTRUCTIONS FRONT STABILIZER BAR

Thank you for purchasing a quality Hellwig Product.

PLEASE READ THIS INSTRUCTION SHEET COMPLETELY BEFORE STARTING YOUR INSTALLATION

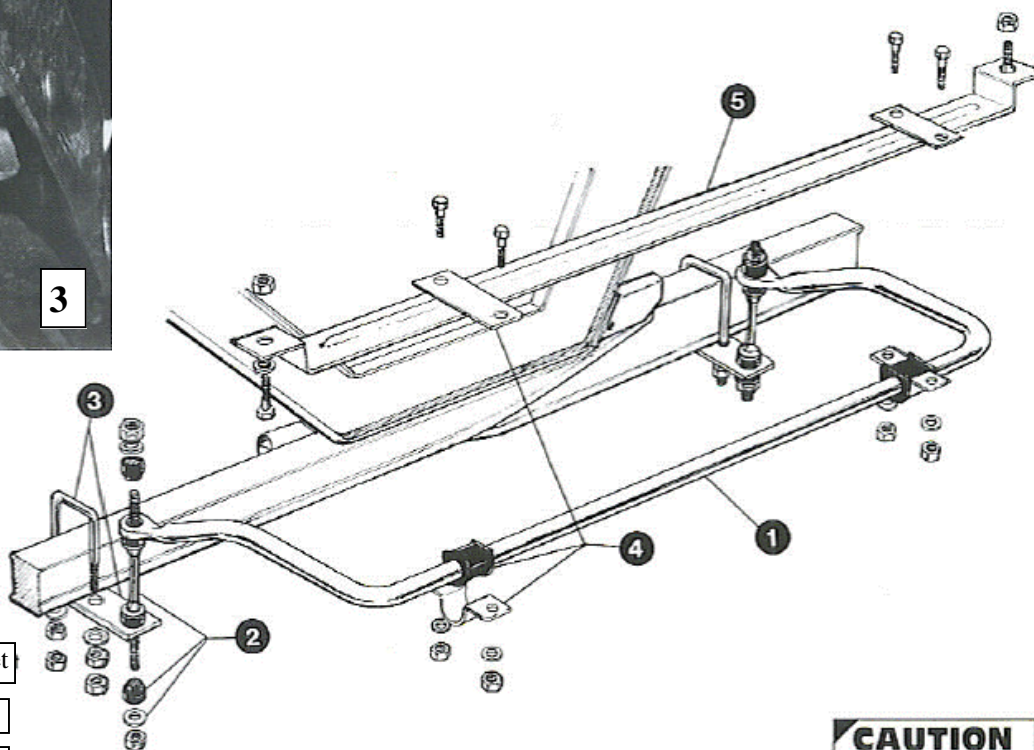
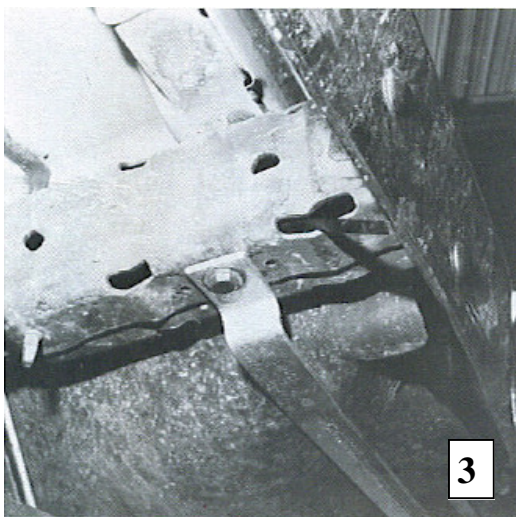
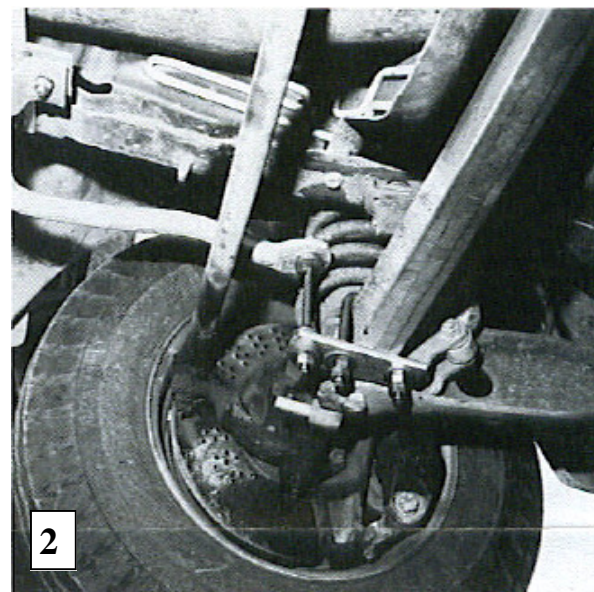
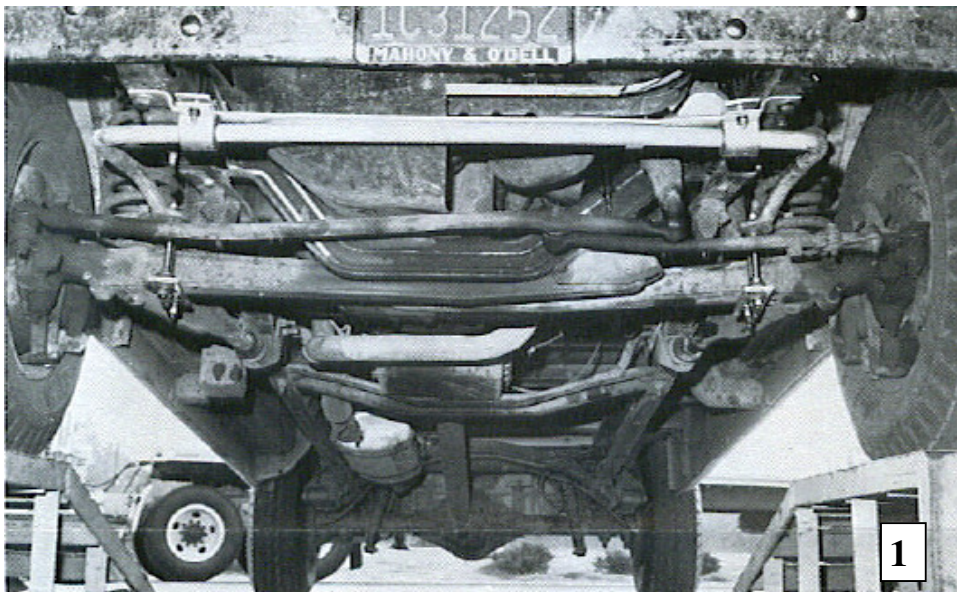

- 1 Sway Bar
- 2 End Link Assembly
- 3 U-Bolt and Axle Bracket
- 4 D-Bushing Bracket
- 5 Cross Member

CAUTION
Stay Clear of Brake Lines

Hellwig PRODUCTS

SAFETY: BEFORE STARTING YOUR INSTALLATION, BE SURE TO SET PARKING BRAKE AND CHOCK TIRES.

NOTE: TO EASE INSTALLATION AND TO PROPERLY ADJUST THE BAR, THE WEIGHT OF THE VEHICLE MUST BE ON THE SUSPENSION, AS IF DRIVING DOWN THE ROAD. DO NOT RAISE VEHICLE BY THE FRAME.

NOTE: THIS KIT MAY INCLUDE LOCK NUTS WHICH REQUIRES TIGHTENING WITH A WRENCH AFTER BEING STARTED BY HAND.

TORQUE TABLE

BOLT SIZE: 3/8" = 20-30 ft. lbs. – 7/16" = 35-45 ft. lbs. – 1/2" = 50-70 ft. lbs. – 9/16" = 70-90 ft. lbs.-5/8"=120 ft. lbs.

1. Install cross-member on frame using 1/2" cap screw and threaded plate, as in Photos 1 and 2. Place threaded plate in frame, centered over large hole, put 1/2" cap screw through hole in cross-member and start into plate. Do not tighten.
2. Put U-bolt assembly on I-beam and install end link on it. Photo 2. Do not tighten.
3. Lubricate the inside and place large D-shaped bushing on sway bar, position bar along cross-member and install mounting components as in Photo 1, then swing ends of bar up onto end link. Follow the line drawing of the end link assembly. **Note:** when tightening lock nuts on end link assembly, tighten just until bushing begins to compress slightly. **DO NOT OVER TIGHTEN.**
4. Position end link so it is in a near vertical position. Tighten U-bolt securely, be sure to double nut U-bolt.
5. Tighten cross-member mounting components. Be sure bar is centered on cross-member before tightening components.
6. Tighten 1/2" cap screws on cross-member.
7. Bounce the vehicle and check for clearance on all undercarriage components with the wheel straight and turned both left and right. Be sure all nuts and bolts are securely fastened and double nuts used where necessary or provided.
8. Recheck your installation, look for clearance between gas lines, exhaust pipes, brake lines, wiring, etc. After one week of driving check your installation and periodically thereafter.

Maintenance and Inspection:

Your Hellwig Suspension Product is built to last. However, as with all vehicle systems, it requires routine inspection. Inspect your Hellwig installation looking for secure hardware and tight fitting brackets and bushings. If you do not perform this inspection, have your professional mechanic inspect as described.

