



Holley Accessory Drive Kit Part Number 20-156 & 20-162

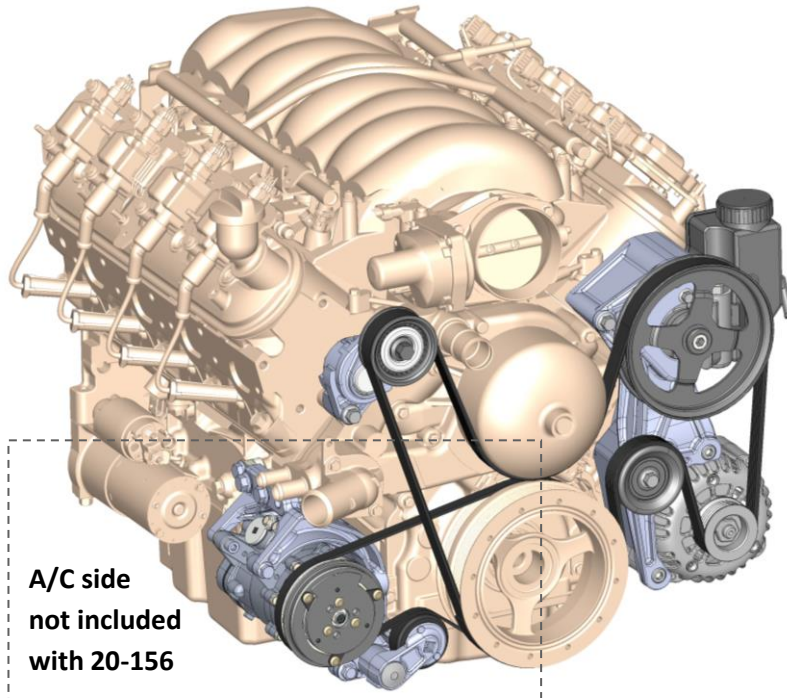
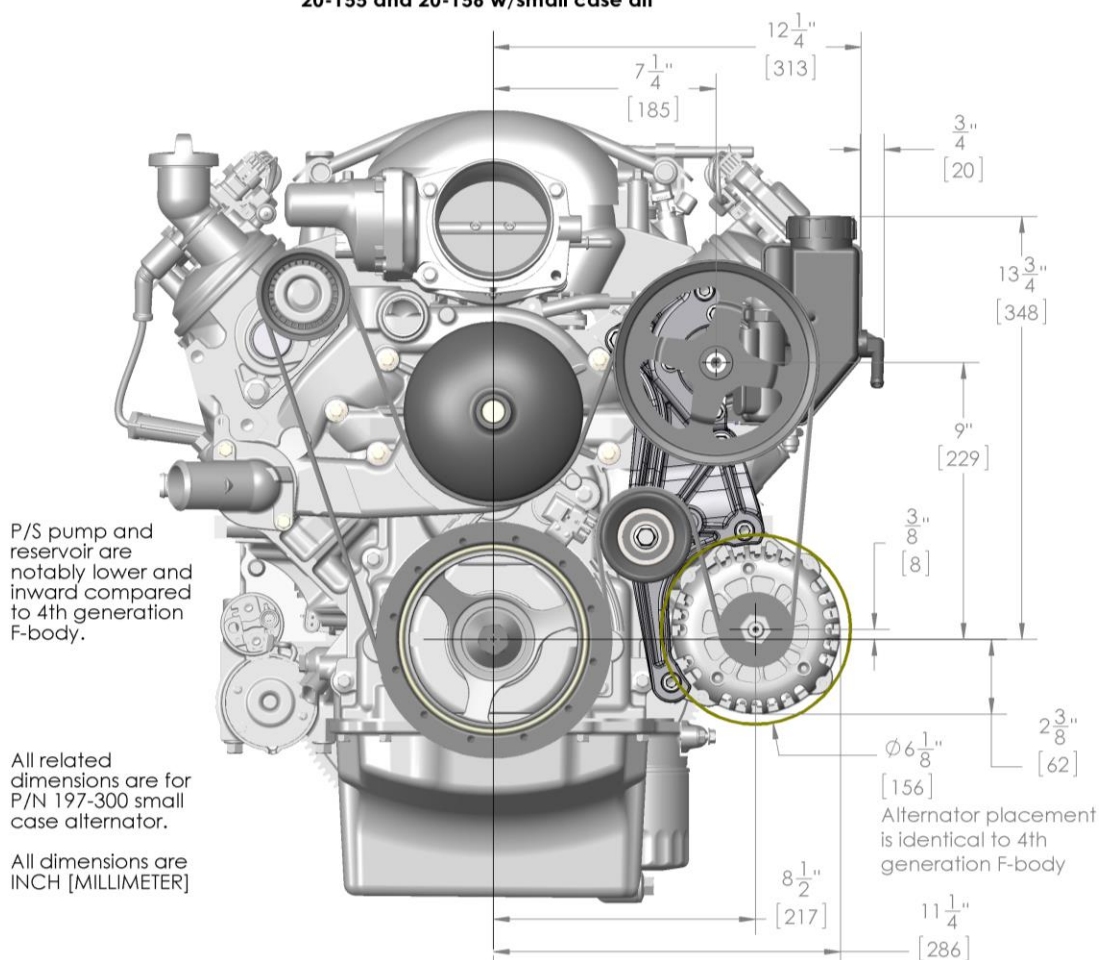

Table of Contents

Introduction:.....	2
Crank Pulley Belt Alignment Determination:	3
Overview of Parts Needed (but NOT included with 20-156 bracket kit):	3
Water Pump Determination and Associated Idler Assembly:	4
Parts List:	7
Driver's Side Bracket Installation:	9
Alternator Installation:	10
P/S Pump/Reservoir Installation:	11
P/S and Idler Pulley Installation (position options):.....	12
Belt Routing & Length Calculation:	13

For part numbers
20-155 and 20-156 w/small case alt



Introduction:

Holley's accessory drive kits offer clean, economical mounting of all LS engine accessories. These brackets look truly at home on any LS engine as if they came from the factory this way. Holley's complete accessory drive systems come with virtually everything needed for installation, from the accessories to the pulleys and even the belt.

This kit can be paired with Holley's low mount A/C bracket kit 20-159 or the engine's original A/C bracket and compressor. This bracket will also work with Holley high mount A/C bracket kit 20-133 or 20-134.

Typically, it is most cost effective to retain the existing crank pulley/water pump and space the bracket and other accessories to match. This bracket does not work with STANDARD belt alignment. If this is the original alignment, the crank pulley and possibly the water pump must be changed. An installation kit (part # 21-4) is REQUIRED for Long belt alignments. No installation kit is required when installing a 20-156 on an application with a MIDDLE belt alignment.

Note: All Corvette part application references in this guide are to NON-supercharged LS engines.

Crank Pulley Belt Alignment Determination:

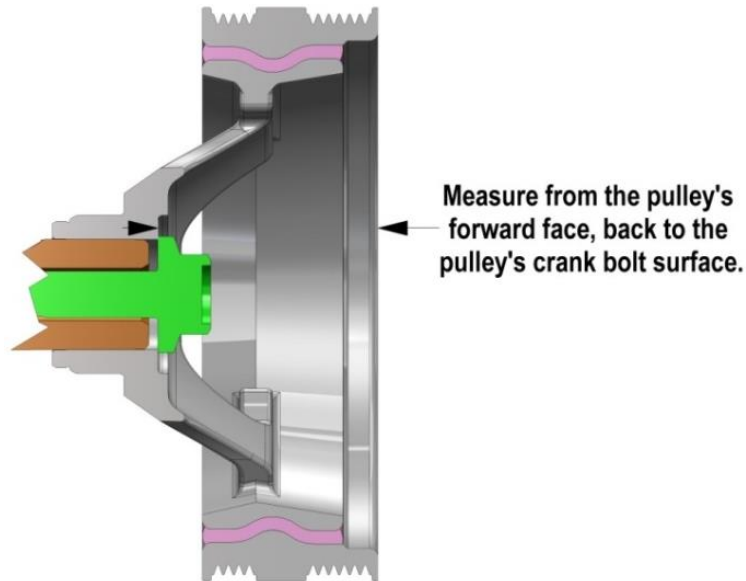

See the below chart for reference dimensions.

Overview of Parts Needed (but NOT included with 20-156 bracket kit):

Components with specific belt alignments

Belt Alignment Group	LS Application (Alignment Specific)	Holley Installation Kit (Alignment Specific)	Crank Pulley (Reference Dimension)		Water Pump (Alignment Specific)	Original Equipment Passenger's side A/C assembly
					GM #	GM # (Numerous)
Standard <u>(will not work with this bracket)</u>	Corvette / CTS-V / G8	N/A	1.5"	37 MM	N/A	<u>Will not work with this bracket</u>
Middle	F-body / GTO	N/A	2.25"	55 MM	19256263	Many LS passenger's side A/C compressors and brackets can be used with this kit, but only in conjunction with the original belt alignment.
Long	Camaro ('10-UP) / Truck (all)	21-4	3"	75 MM	19207665 or any truck WP	

Components that will work with all belt alignments

	Passenger's Side A/C Bracket
	Holley #
	Low mount: 20-159
	High mount: 20-133 and 20-134 (also requires installation kit 21-2, or 21-3)

NOTE: If installing A/C, follow assembly instruction supplied with that bracket before proceeding.

Water Pump Determination and Associated Idler Assembly:

To determine which water pump type you have, refer to the following illustrations-

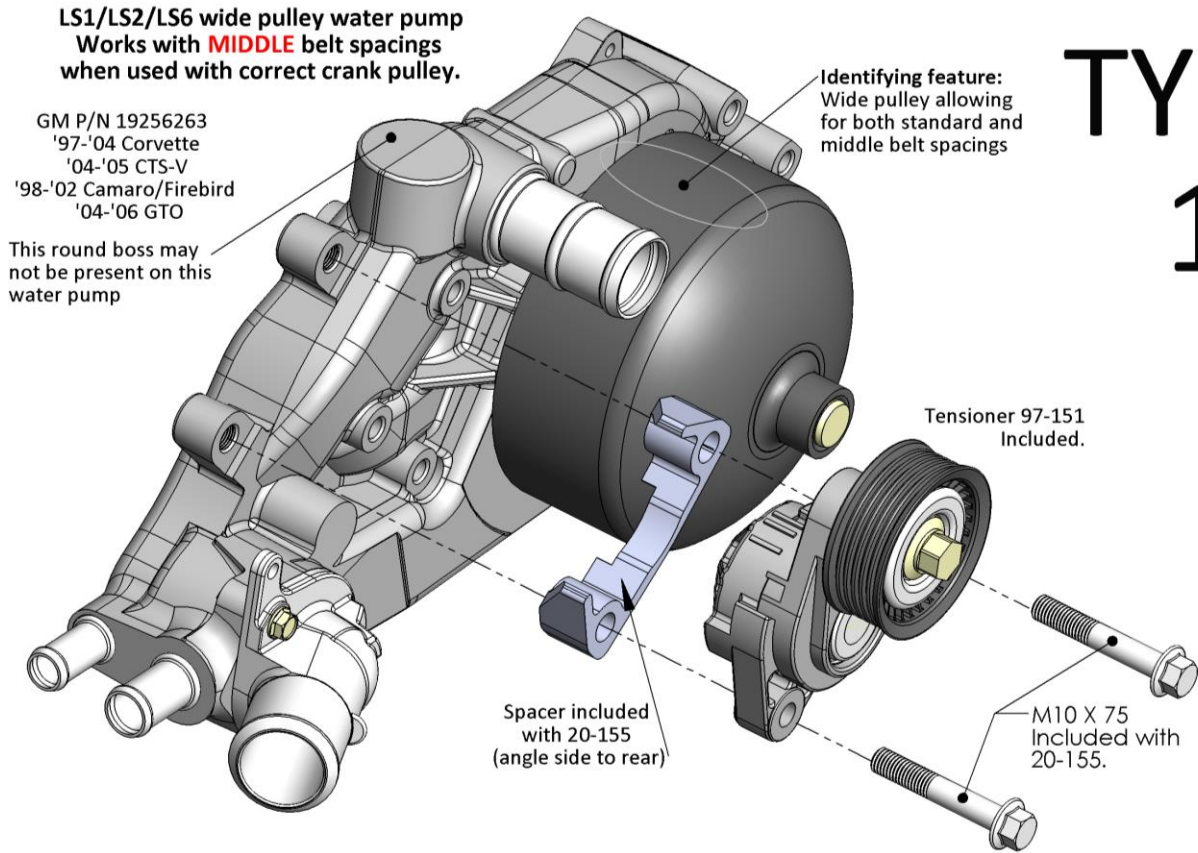

Holley Water pump - part # 22-100

LS2 Specific water pump
Works with **STANDARD**
belt spacing **ONLY**

GM P/N 89018052
'05-'07 Corvette
'06-'07 CTS-V

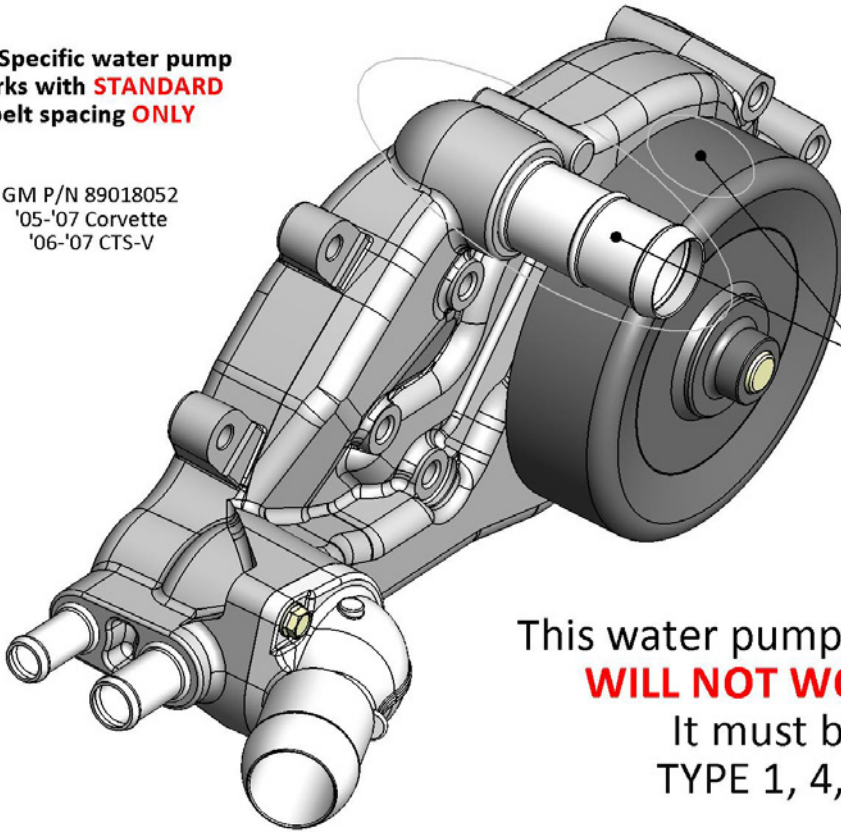

TYPE 2

Identifying features:
Narrow pulley and
passenger's side outlet

This water pump and respective tensioner
WILL NOT WORK with this bracket.
It must be replaced with a
TYPE 1, 4, or 5 water pump.

LS3 Corvette/G8 water pump
Works with **STANDARD**
belt spacing **ONLY**

GM P/N 12604630
'08-UP Corvette
'08-'09 G8

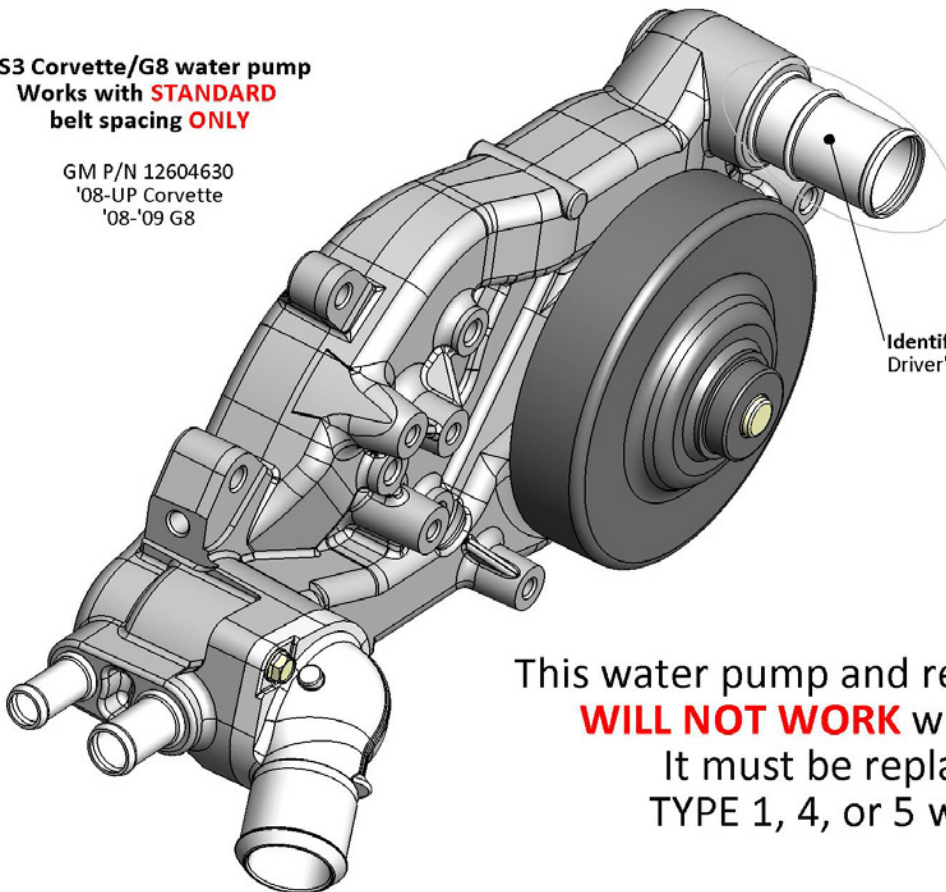

TYPE 3

Identifying feature:
Driver's side outlet

This water pump and respective tensioner
WILL NOT WORK with this bracket.
It must be replaced with a
TYPE 1, 4, or 5 water pump.

LS3/L99 Camaro water pump
Works with **LONG** belt spacing

GM P/N 19207665
'10-UP Camaro

Identifying feature:
Long tensioner Bosses

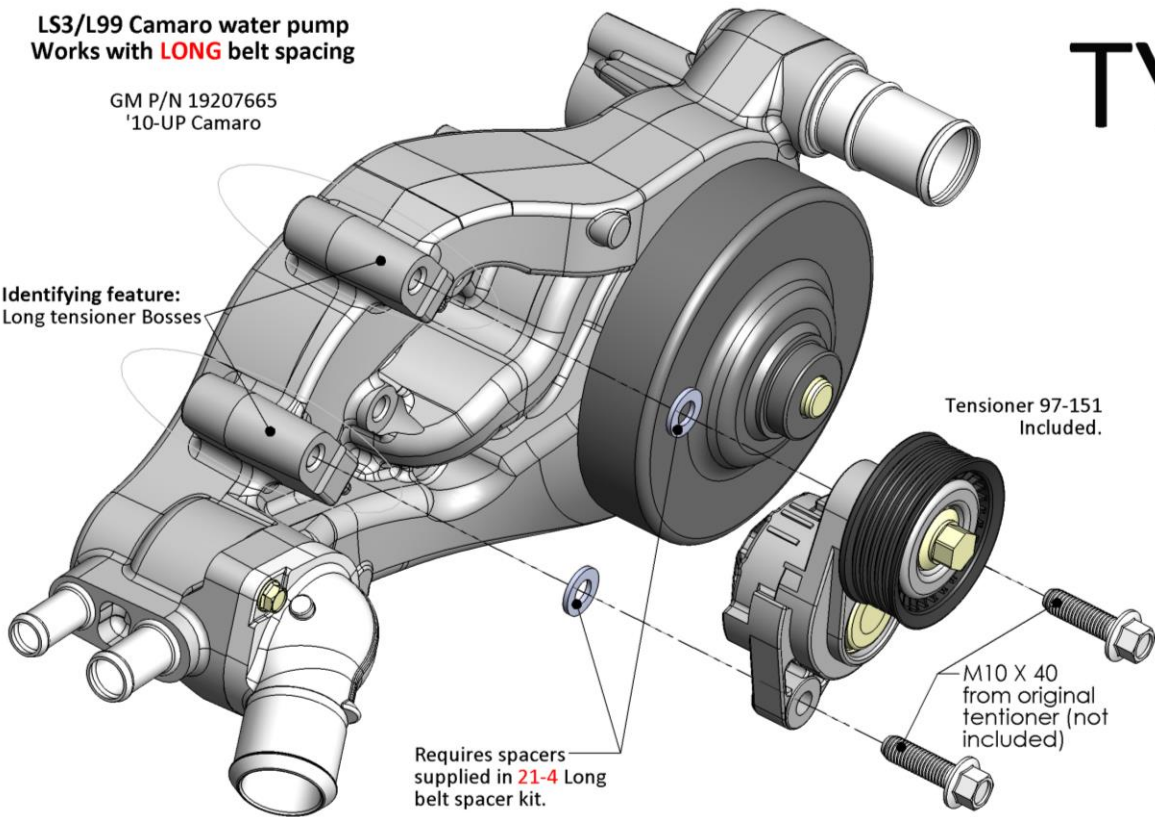

TYPE 4

Holley Water pump - part # 22-101

TRUCK water pump
Works with **LONG** belt spacing

GM P/N (Numerous)
All truck LS based engines

Identifying feature:
Upward pointing
outlet

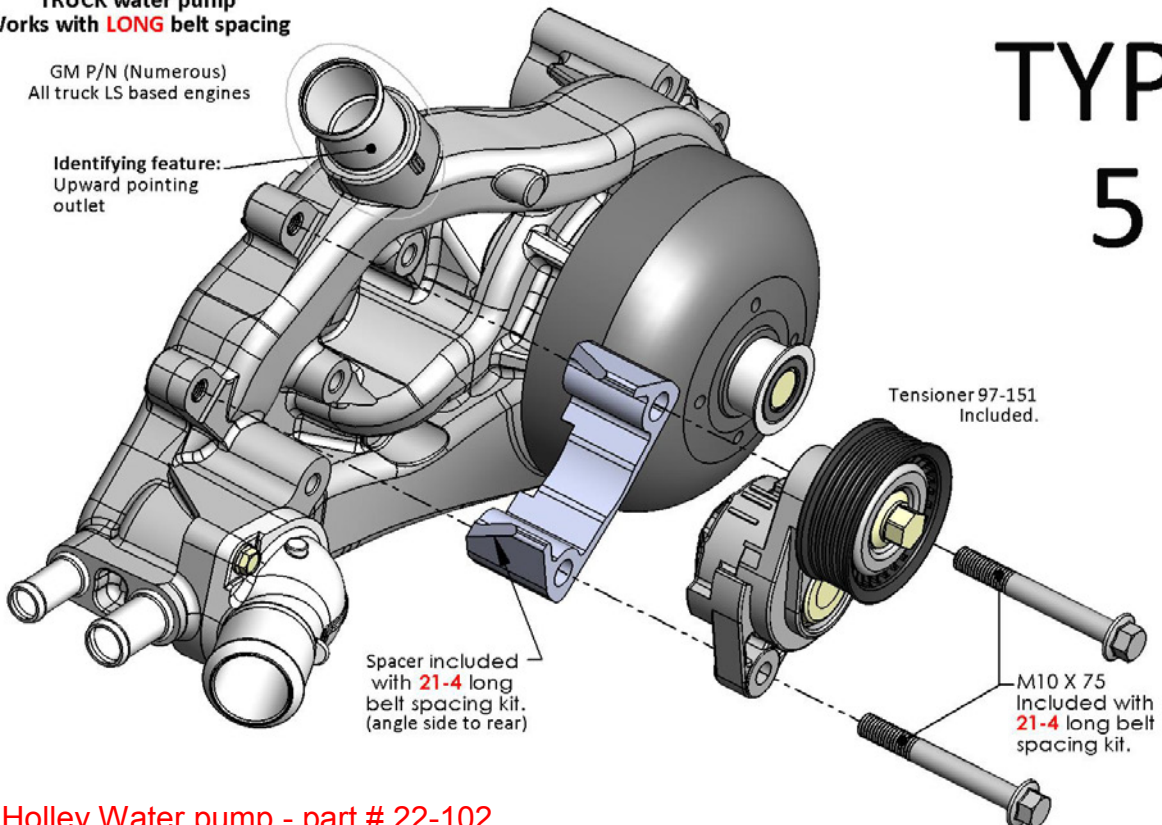









TYPE 5

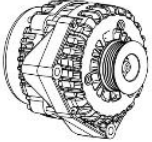

Holley Water pump - part # 22-102

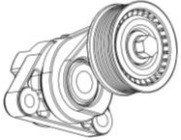
Parts List:

- If used with Long belt alignments, this bracket requires installation kit part # 21-4. For Middle alignments no installation kit is required. This bracket will not work with Standard alignment.

Parts included with 20-156 bracket kit (see list supplied with installation kit for additional parts):

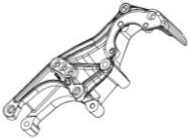
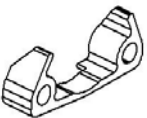
PICTURE	QTY	DESCRIPTION	APPLICATION
	1	Alternator (P/N 197-300)	Driver's Side Bracket
	1	P/S Pump (P/N 198-101)	Driver's Side Bracket
	1	Hardline (P/N 198-202)	P/S Pump
	1	Smooth Idler Pulley (P/N 97-150)	Driver's Side Bracket
	1	Belt Tensioner with Ribbed Pulley (P/N 97-151)	Water Pump, Passenger's Side
	1	Pigtails (P/N 197-400)	Alternator
	1	Ribbed Pulley (P/N 97-152)	P/S Pump
	1	Belt, 6 Rib Serpentine	Driver's Side Bracket

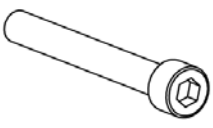
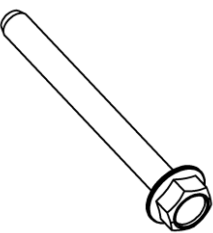
PICTURE	QTY	DESCRIPTION	APPLICATION
	1	Driver's Side Bracket Assembly	Alternator & Power Steering Pump
	1	Tensioner spacer	Use with standard alignment tensioner to move to middle belt alignment (NOT used with Long belt alignments)
	1	Step Spacer	Driver's Side Idler Pulley
	1	Socket Head Cap Bolt, M10 x 1.5 x 105	Bracket to Head (NOT used with Long belt alignments)
	1	Socket Head Cap Bolt, M10 x 1.5 x 105	Bottom Alternator Bolt to Block (NOT used with Long belt alignments)
	1	Socket Head Cap Bolt, M10 x 1.5 x 80	Top Alternator Bolt
	3	Flange Head Bolt, M8 x 1.25 x 35	Power Steering Pump Bolts
	1	Flange Head Bolt, M10 x 1.5 x 50	Idler Pulley to Bracket
	2	Flange Head Bolt, M10 x 1.5 x 60	Tensioner to Water Pump (NOT used with Long belt alignments)
	1	Flange Head Bolt, M10 x 1.5 x 90	Bracket to Upper Head (NOT used with Long belt alignments)
	1	Flange Head Bolt, M10 x 1.5 x 100	Bracket to Lower Head (NOT used with Long belt alignments)

Driver's Side Bracket Installation:

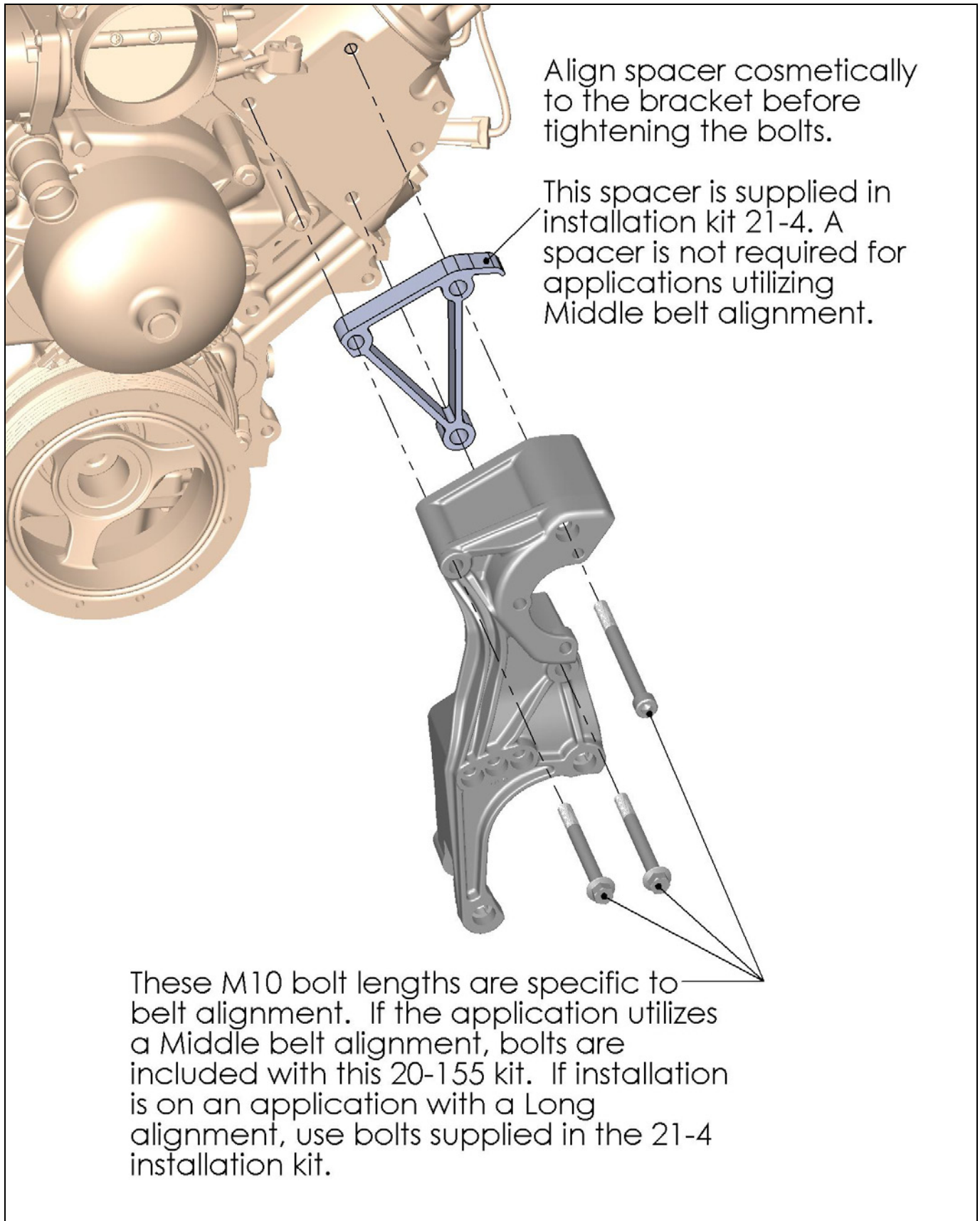

NOTE: Torque M8 bolts to 18 ft./lbs. and M10 bolts to 36 ft./lbs.

Alternator Installation:

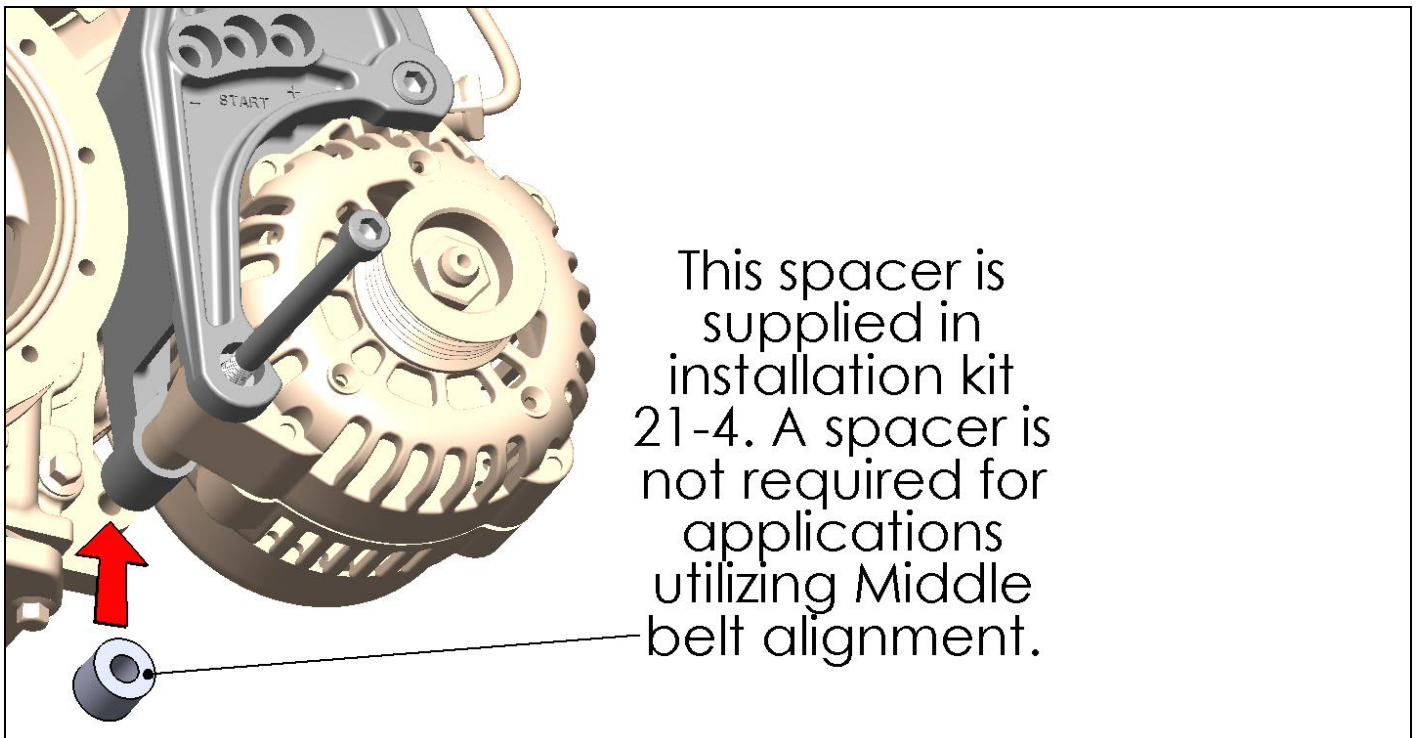
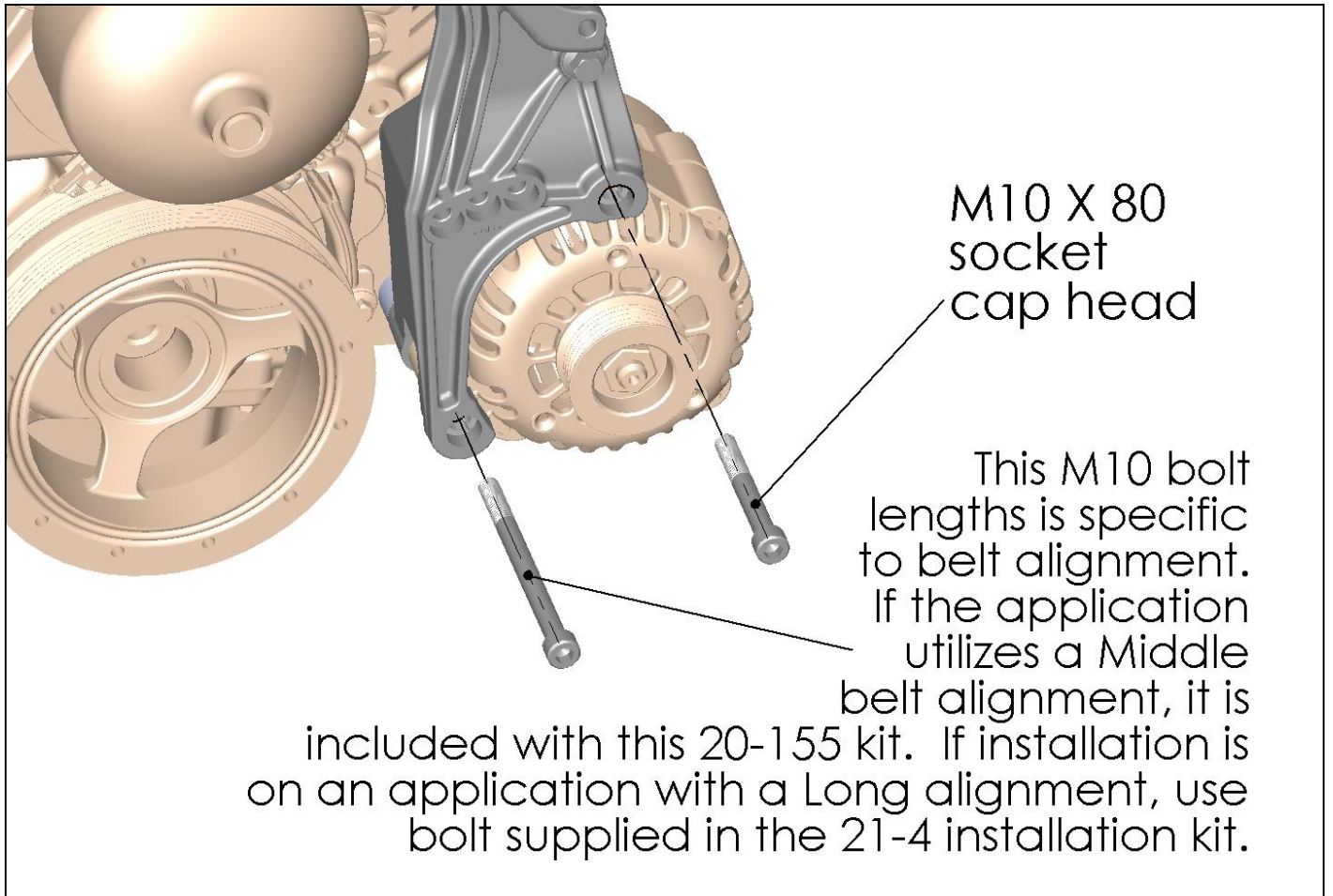

NOTE: Torque M8 bolts to 18 ft./lbs. and M10 bolts to 36 ft./lbs.

Helpful hint: When wiring the alternator, install the included 197-400 plug into the alternator. Next connect the yellow wire to switched voltage that is "on" when the key is in the run position. If the vehicle has a "charge indicator light" the yellow wire can be connected to that circuit.

P/S Pump/Reservoir Installation:

Install the 198-202 power steering AN adapter/tube, assemble at this time.

Step One

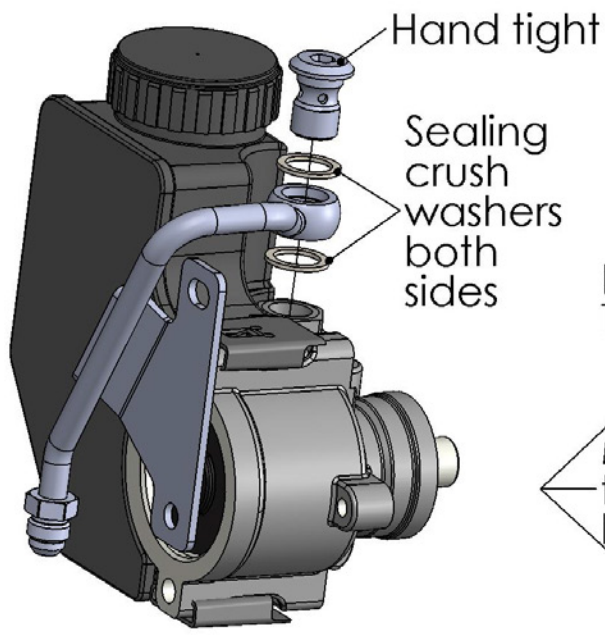

Step Two

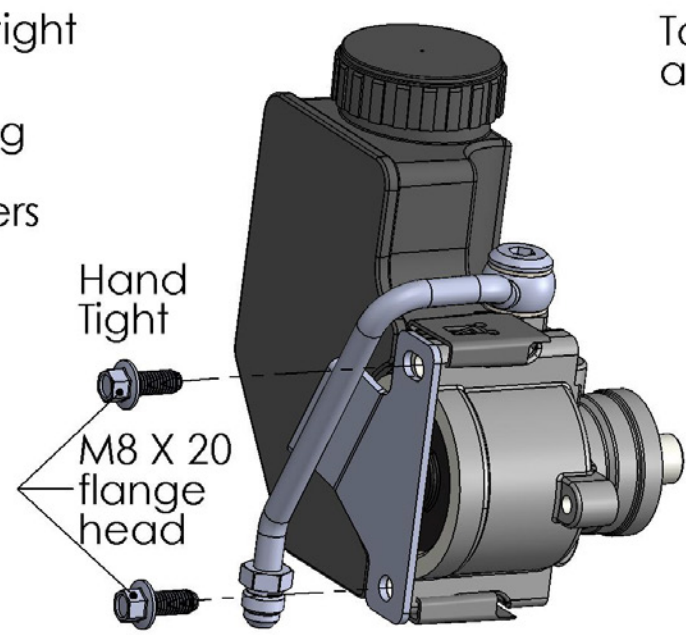

Step Three

Torque all bolts

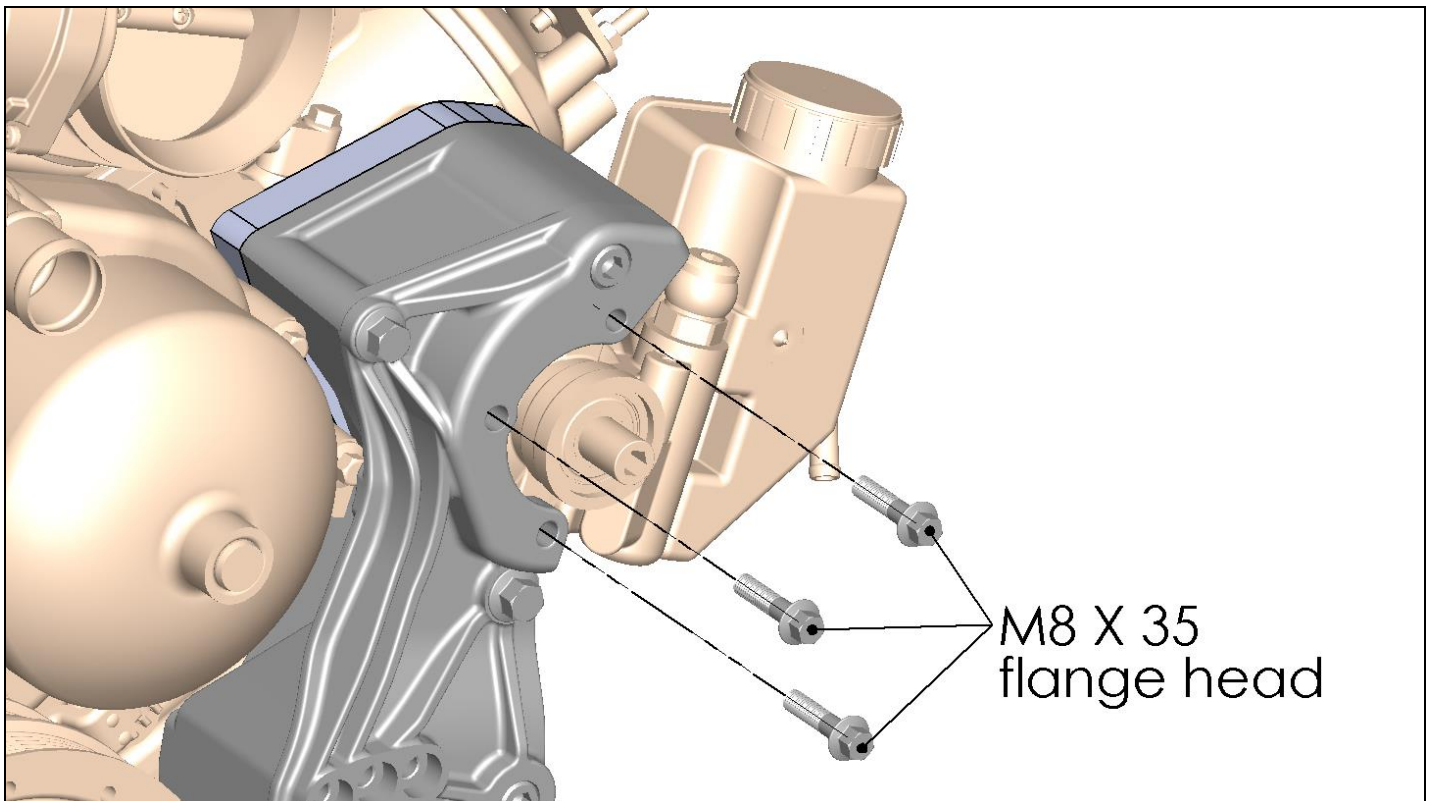

NOTE: Torque M8 bolts to 18 ft./lbs. and banjo bolt to 25 ft./lbs.

P/S and Idler Pulley Installation (position options):

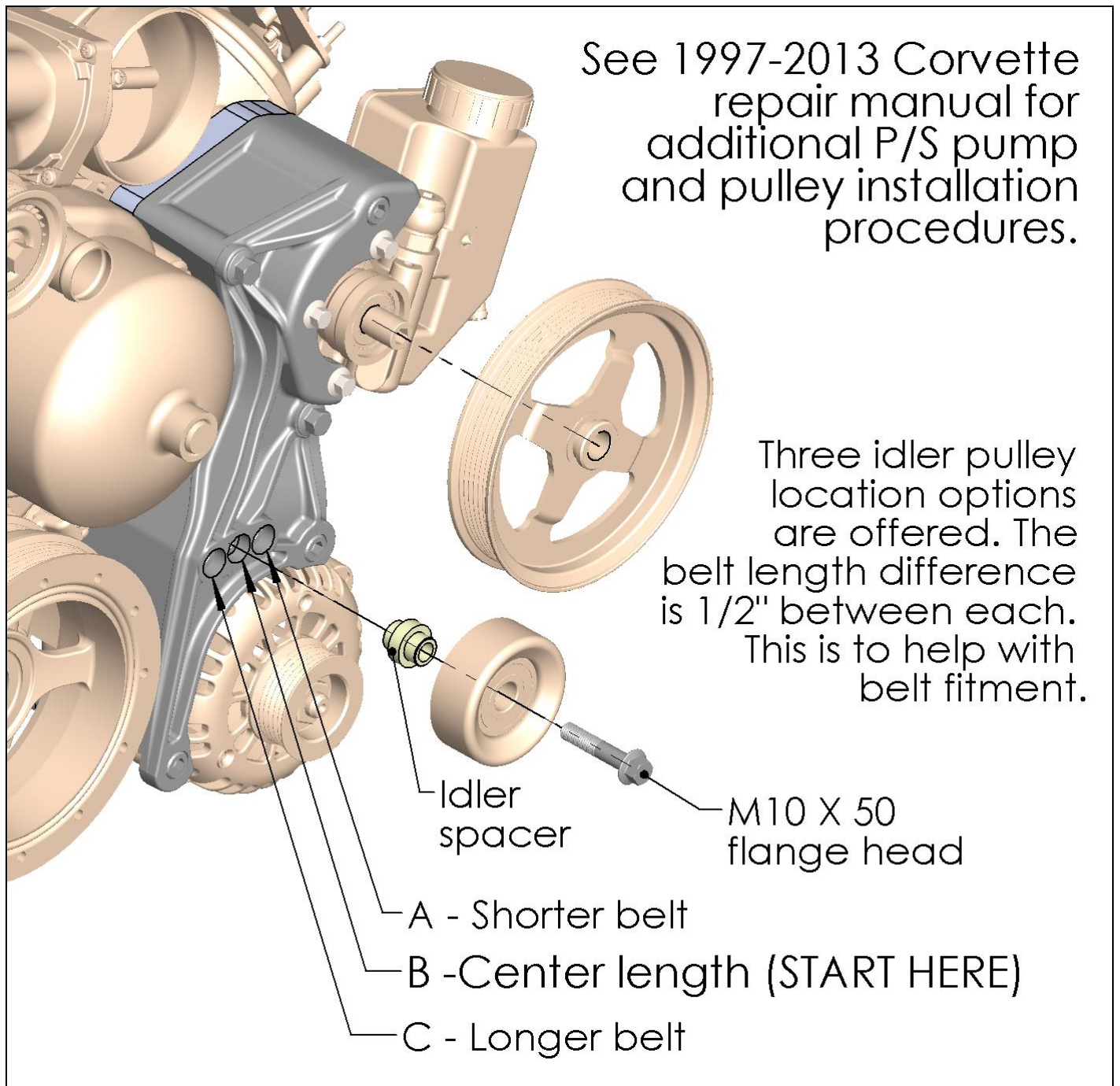

NOTE: Torque M8 bolts to 18 ft./lbs. and M10 bolts to 36 ft./lbs.

The P/S pulley must be installed using an installation tool that can be rented at most auto parts stores. Incorrect installation of this pulley may damage the P/S pump internals. When installed, the pulley bore face should be flush with the end of the pump shaft.

Helpful hint: Open faced pulley part 97-152 (included) can be installed onto pump before bracket assembly as bolts can be accessed through pulley windows.

Belt Routing & Length Calculation:

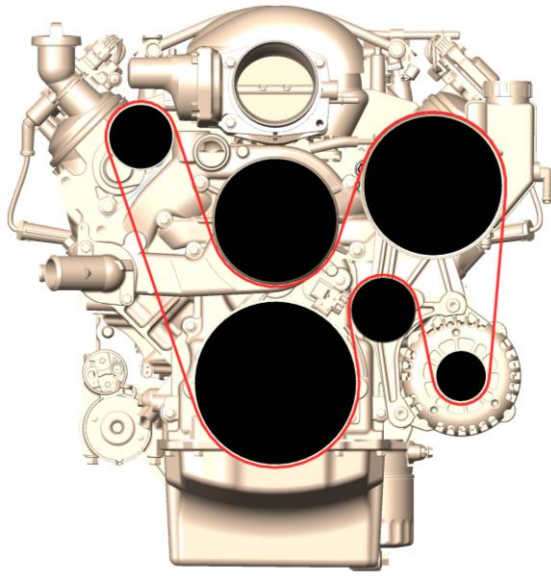

Standard

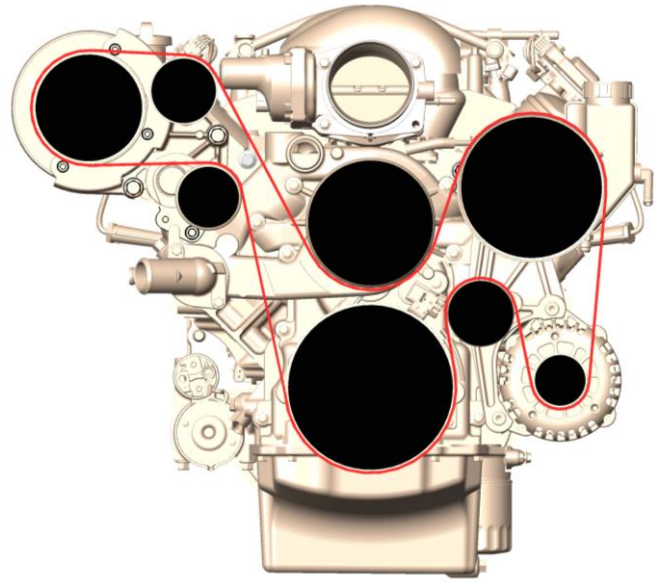

Alternate routing with AC bracket
(requires sourced belt)

HELPFUL HINT: When installing the belt, route around all the pulleys except the water pump pulley. While fully rotating the tensioner arm, slip the belt on the smooth water pump pulley last.

Use serpentine belt supplied if using ALL included Holley accessories and supplemental parts.

NOTE: If you are NOT using all the Holley accessories supplied, or have changed the original crank or any accessory's pulleys, you will have to measure to find the correct belt length.

To acquire this measurement, perform the following:

After all brackets and accessories are installed, route masking tape or string around the belt path. Leave the tensioner in the un-sprung position for this measurement. Mark or cut the tape/string to length and remove from the pulleys. Subtract 1 1/8" (28 mm) from the measured length to compensate for the un-sprung tensioner position. You will need to convert belt length to millimeters if measured in inches (inches X 25.4 = mm). Go to any auto parts store and ask for a 6PK0000 belt with the "0000" being the length in millimeters. For example, if you measured 2493 mm and then subtracted 28 mm, you would get 2465 mm, and the part number would be 6PK2465. Remember, if you miss on size, the driver's side idler can be moved to decrease the required belt length by 1/2".

