

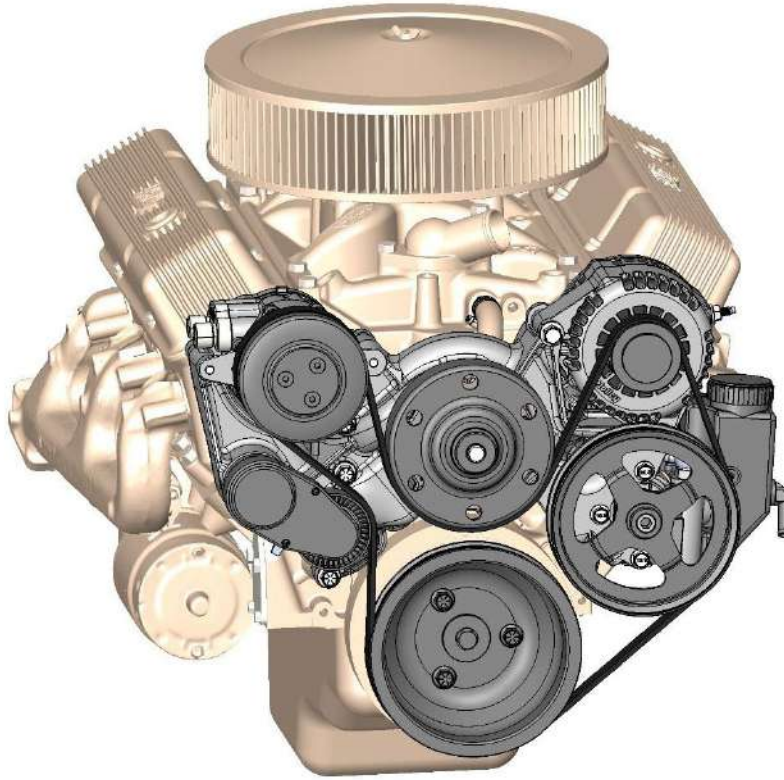

Complete Holley Mid-Mount Accessory Drive Kit

Part Numbers: 20-240, 20-241, 20-242, and 20-243 – also BK (black) and P (polished) versions











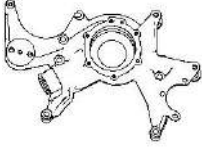







Holley's Mid-Mount complete accessory system has all accessories pulled in tighter than other accessory drives. Among the many features is the bracket-less assembly that actually mounts all accessories to the water pump directly.

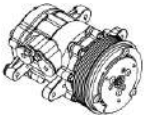



Features:



- Bracket-less accessory mounting with ultra-easy assembly
- Hidden heater hose and bypass ports
- LT1 style premium alternator
- LT1 cartridge style water pump design
- Compact SD7 A/C compressor
- Type II power steering pump with baffled reservoir
- OE pulley ratios for optimal accessory performance
- Available for SBC and BBC applications
- Heater, A/C and P/S line adapters included
- Tensioner, alternator pulley and compressor pulley billet covers
- Billet crank pulley can be machined to allow the addition of a crank trigger

Parts List:

PICTURE	QTY	DESCRIPTION	REPLACEMENT MANUFACTURER & P/N
	1	Manifold Assembly, Water Pump	SBC: 97-305 (natural) / 97-306 (natural W/O P/S) 97-309 (black) / 97-310 (black W/O P/S) / 97-313 (polished) / 97-314 (polished W/O P/S) BBC: 97-307 (natural) / 97-308 (natural W/O P/S) 97-311 (black) / 97-312 (black W/O P/S) / 97-315 (polished) / 97-316 (polished W/O P/S)
	1	O-ring Gaskets, Water Pump to Block	Holley 97-304 (SBC), 97-322 (BBC)
	1	Water Pump Drive Assembly	Holley 97-200
	1	Gasket, Water Pump Assembly	GM 12619770
	1	Belt, 6 Rib Serpentine	BANDO 6PK1615 (SBC), 6PK1550 (SBC W/O P/S), 6PK1690 (BBC), 6PK1625 (BBC W/O P/S),
	1	Adapter Manifold for A/C Compressor	Holley 199-202
	1	NPT Fittings, SBC 3 Adapters & 2 Plugs / BBC 3 Adapters & 1 Plugs	Holley 97-301 (SBC) / 97-319 (BBC)
	1	Alternator	Holley 197-302 (natural) / 197-303 (black) / 197-304 (polished)
		Harness Pigtail, Alternator	Holley 197-400
	1	Tensioner Assembly with Smooth Pulley	Holley 97-179 or Gates 38163
	1	SD7 A/C Compressor	Holley P/N 199-102 (natural) / 199-104 (black) / 199-106 (polished)

PICTURE	QTY	DESCRIPTION	REPLACEMENT MANUFACTURER & P/N
	1	Crank Pulley	Holley 97-317 (SBC) / 97-318 (BBC)
	1	Crank Center Bolt & Washer	Holley 97-320 (SBC) / 97-321 (BBC)
Included Only With: 20-240 and 20-242 (also BK and P versions)			
	1	P/S Pump with Reservoir	Holley 198-101
	1	P/S Pressure Hardline to -6 AN, Banjo Bolt, crush washers (2), & Hardware	Holley 198-203
	1	P/S Pulley	Holley 97-152

HARDWARE	(REPLACEMENT: SBC 97-302, BBC 97-303)	HARDWARE APPLICATION	
	1	Oversized Washer, M8	Tensioner
	1	Button Head Bolt, M8 X 1.25 X 70	Tensioner
	2	Button Head Bolt, M10 X 1.5 X 80	Alternator
	6	Button Head Bolt, M6 X 1.0 X 20	Water Pump to Manifold
	1	Socket Head Bolt, 3/8-16 X 3"	Manifold to Engine Block
	3	Flange Head Bolt, 3/8-16 X 4 1/2"	Manifold to Engine Block
	2	Flange Head Bolt, M8 X 1.25 X 95	A/C Compressor
	2	Flange Head Bolt, 3/8-16 X 2"	Manifold to Engine Block (SBC only)
		Flange Head Bolt, 7/16-14 X 2"	Manifold to Engine Block (BBC only)
	3	Flange Head Bolt, 3/8-24 X 1 1/4"	Crank Pulley (24 thread-pitch typical on SBC and some BBC)
	3	Flange Head Bolt, 3/8-16 X 1 1/2"	Crank Pulley (16 thread-pitch typical on BBC and some SBC)
	3	Flange Head Bolt, M8 X 1.25 X 30	Power Steering Pump (if applicable)

Included With: All Part Numbers			
	1	Alternator Pulley Cover & O-ring	Holley 97-187 (black) / 97-188 (polished)
	1	A/C Compressor Pulley Cover & Hardware	Holley 97-185 (black) / 97-186 (polished)
	1	Tensioner Cover & Hardware	Holley 97-158 (black) / 97-157 (polished)

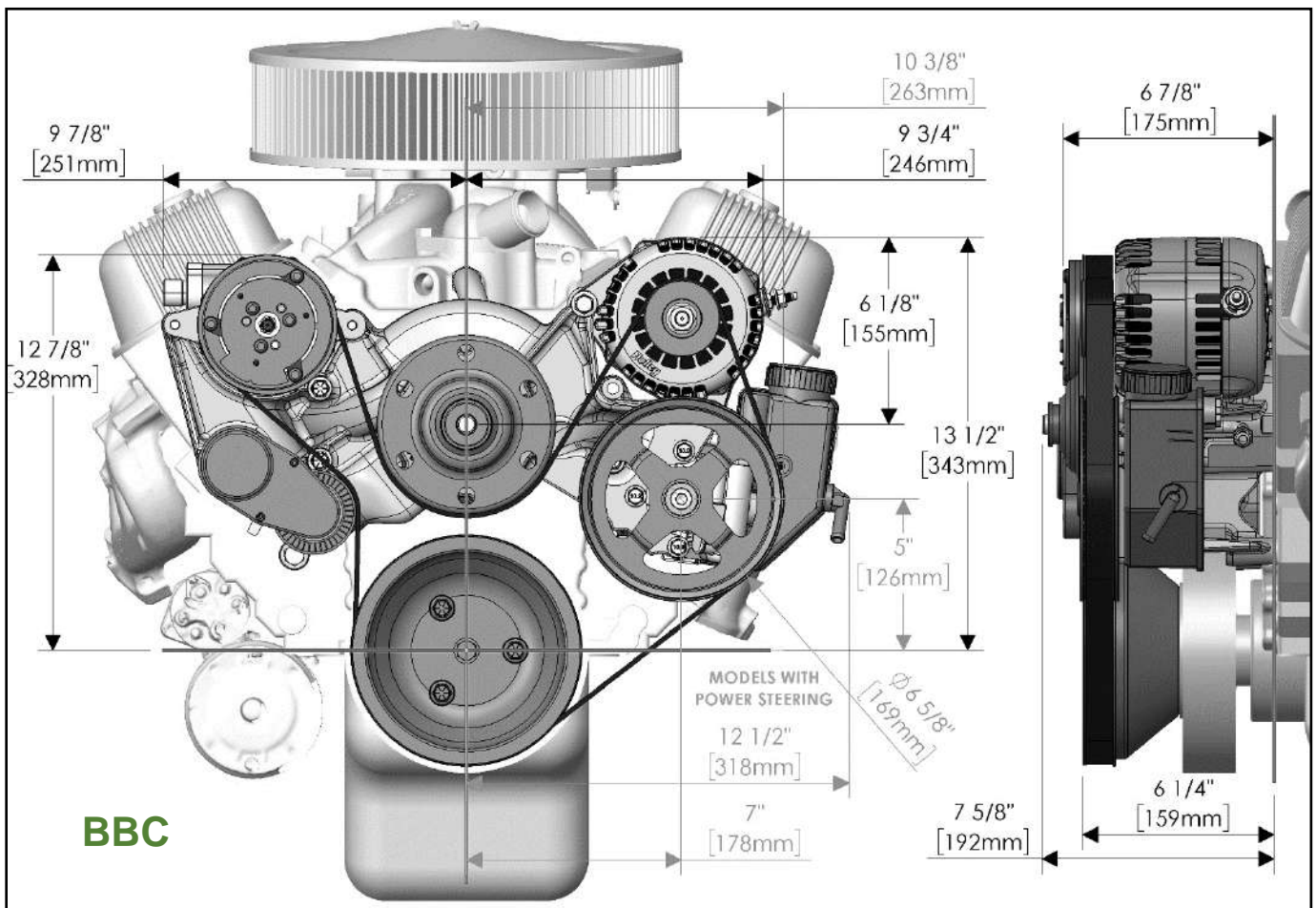
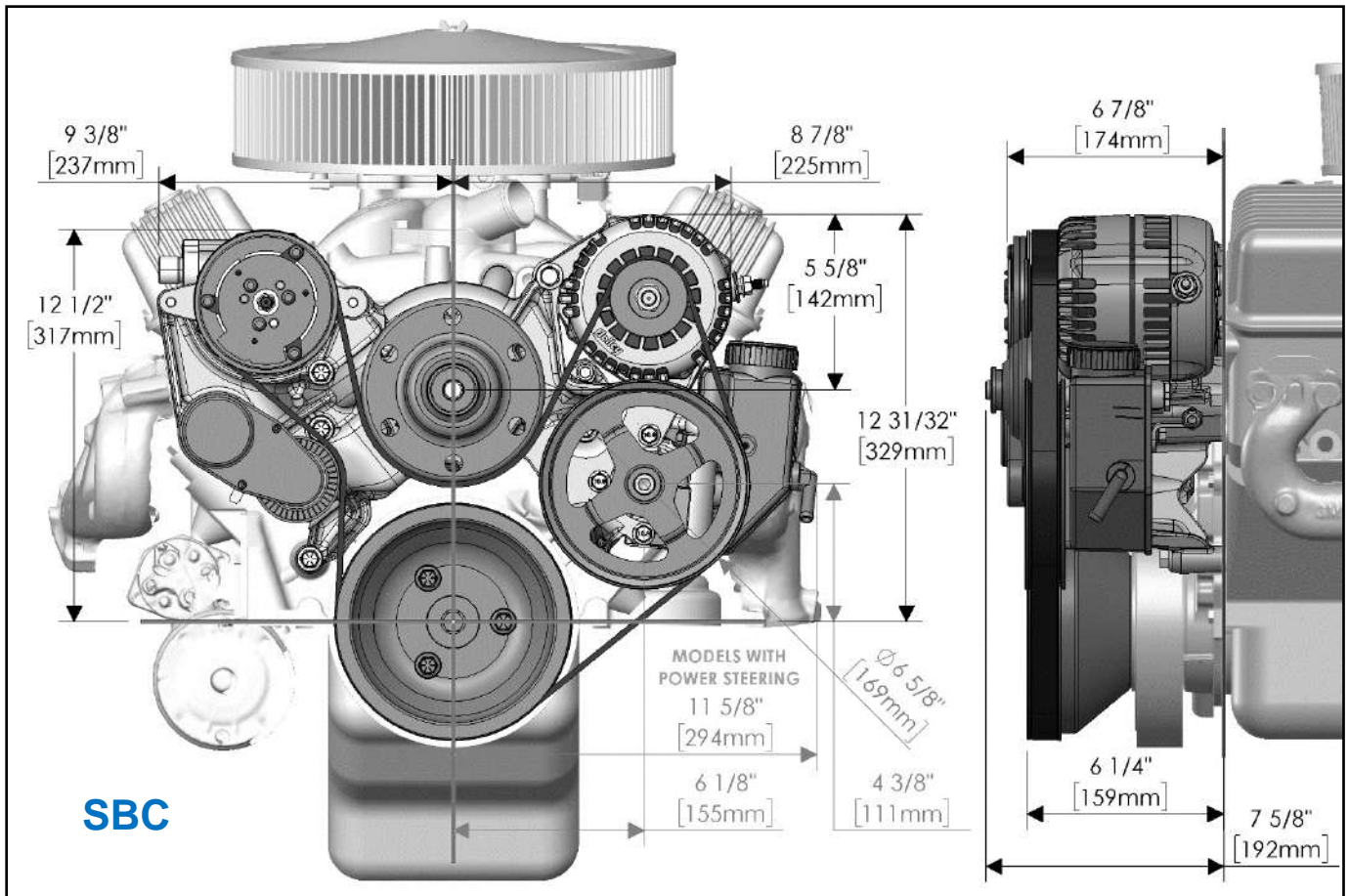

IMPORTANT NOTE IF PAINTING COMPONENTS: The alternator and A/C compressor ground through the water pump manifold. If painting or coating the manifold, the mating surfaces must all be bare metal allowing a ground path from the accessories' mounting feet to the engine block and ultimately the negative terminal on the battery.

Assembly Instructions

NOTE: Components in assembly graphics may vary some from those supplied for your application.

HELPFUL HINT: The below assembly order is optimized for explanation and the average application. It may be easier to preassemble some components to the manifold before mounting to the engine. Torqueing of the components may however be easier after mounting. The only component that cannot be preassembled is the tensioner, as it would prevent access to a mounting bolt. Keep in mind that adding components increases overall size and weight and may require an additional person when mounting.

Crank Pulley Installation:

Crank trigger applications - there is enough material on the rear surface of the crank pulley to remove up to 3/8" for the addition of a crank trigger wheel. This modification should be done by a qualified machinist.

Gen VI BBC - some late model BBC OE dampers may require a smaller locating boss than the supplied pulley has. If so, there is enough material on the supplied pulley that the diameter can be reduced to fit. This modification should be done by a qualified machinist.

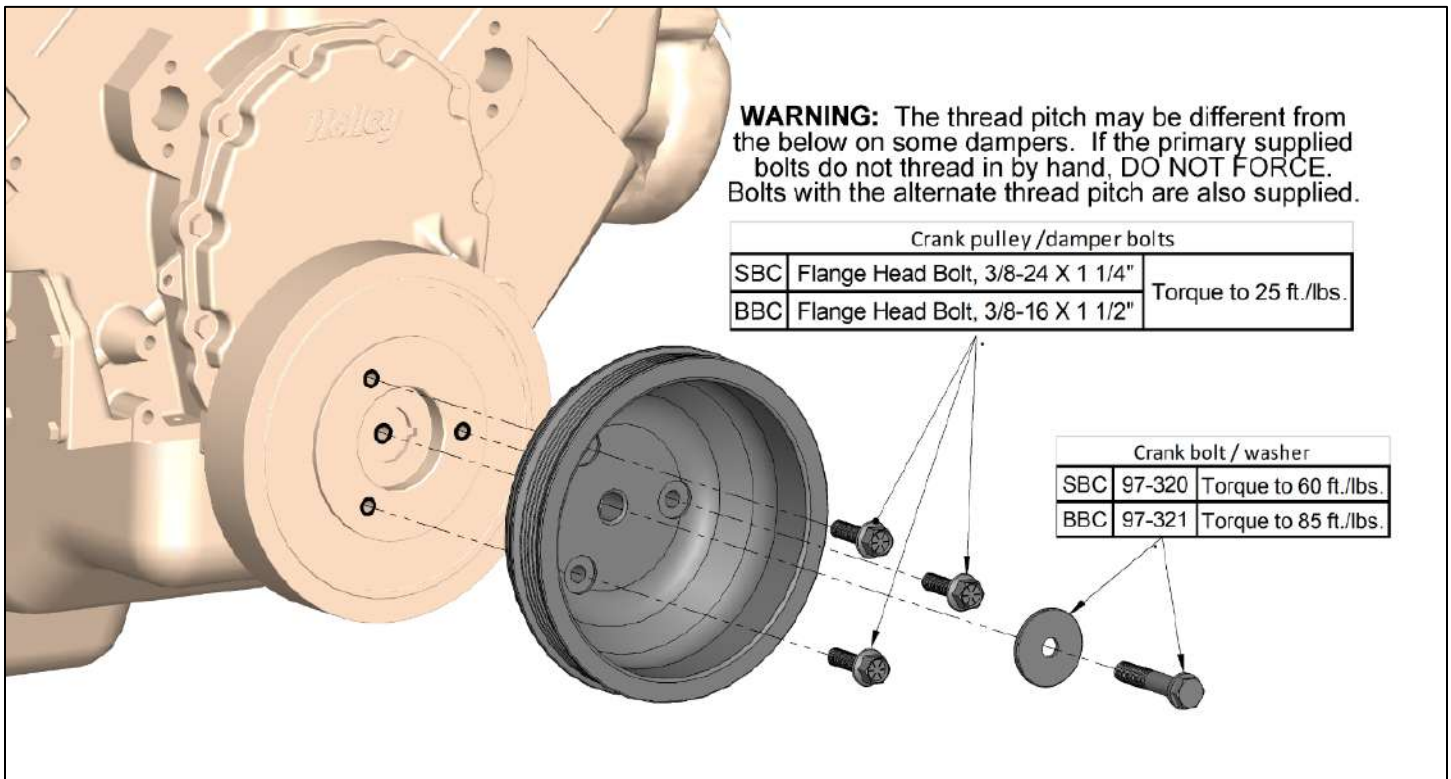

Sealing to Engine Block:

O-ring sealing option - most manifolds have an O-ring groove and included O-rings. If your version has this feature AND your bock face is flat and free of scratches, install the O-rings as shown below.

NOTE: Apply a silicone lubricant to the O-rings before installation, then carefully work them down into the groove in an even manor.

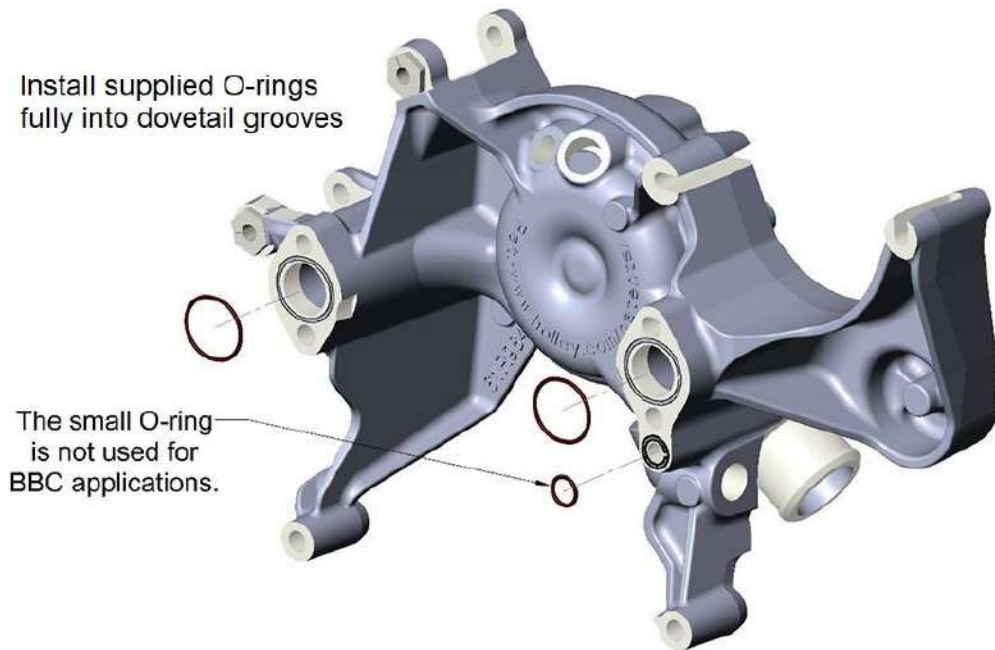

Gasket sealing option - if your manifold does not have O-ring grooves OR if your block sealing surface is rough or uneven, follow the below instructions:

Install thin water pump gaskets as shown.
SBC - Mr. Gasket P/N 70G (2 sets required)
BBC - Mr. Gasket P/N 71G (2 sets required)
(Two gaskets are included with each above P/N)

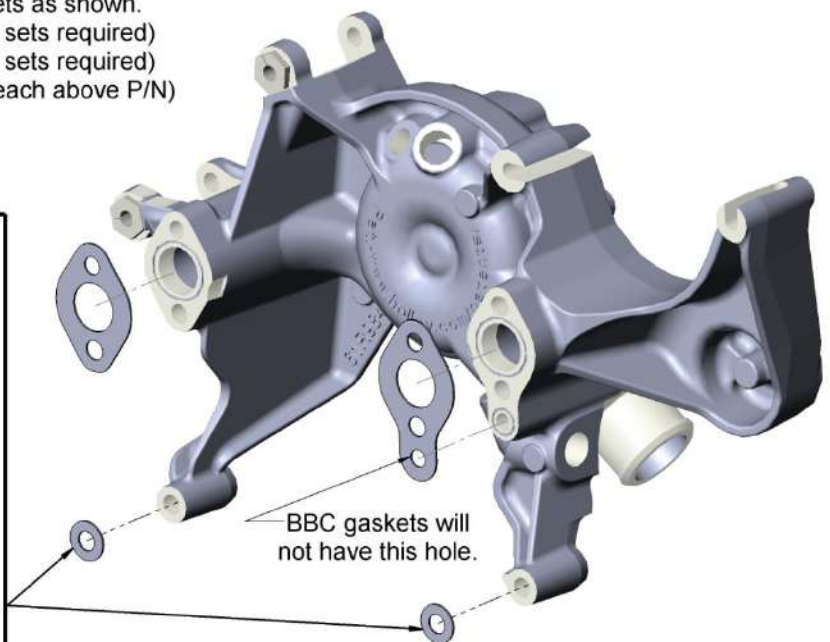
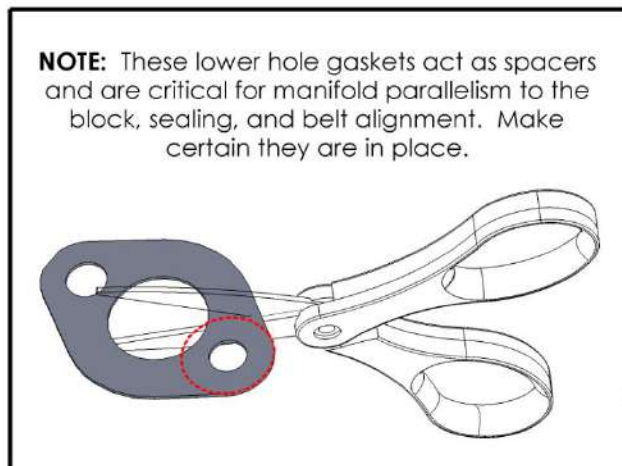

NPT Adapter Configuration and Installation:

Install NPT adapters in the configuration that supports your application.

If your application utilizes a Thermostat bypass, a water pump port and two short NPT adapters are included.

In most cases the routing does not require a formed hose. If your application does not have a bypass, plug this water pump port with an NPT plug.

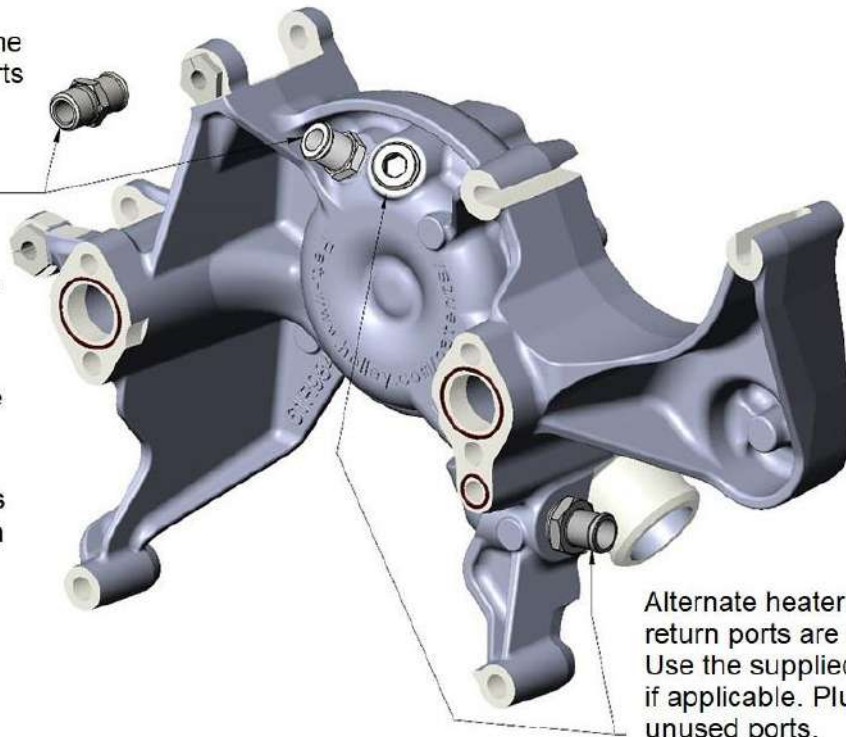

Alternate heater hose return ports are available. Use the supplied adapter if applicable. Plug any unused ports.

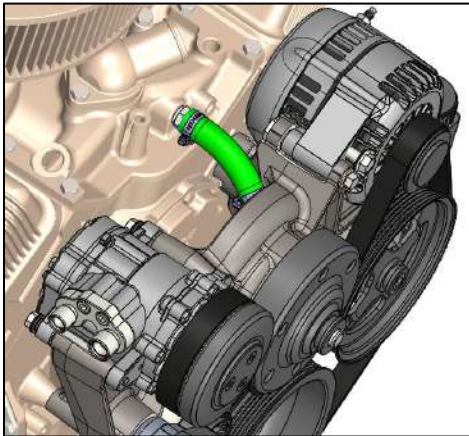

Thermostat bypass with standard-hose installation shown in green to the left. Hose and clamps not included.

On all NPT adapters, use thread sealant (Loctite® brand 567 pipe thread sealant or equivalent).

Install to finger tight, and then tighten 2 to 3 rounds.

Water Pump and Gasket Installation:

NOTE: Torque M6 button head bolts to 85 in/lbs. Use a standard 3mm hex tool. Do not use a ball hex tool.
Do not overtighten.

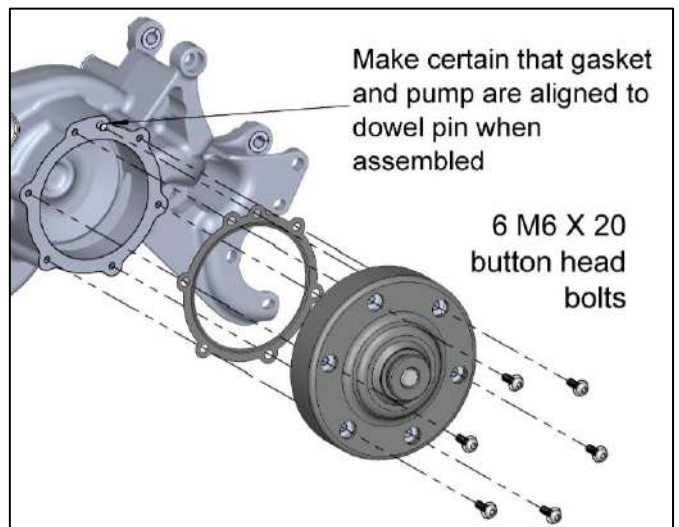

Make certain that gasket and pump are aligned to dowel pin when assembled

6 M6 X 20
button head
bolts

Water Pump Manifold Assembly installation:

NOTE: Make certain the block sealing surfaces are clean of any gasket material and all other contaminants that may cause sealing issues. Make certain all O-rings or gaskets are in place.

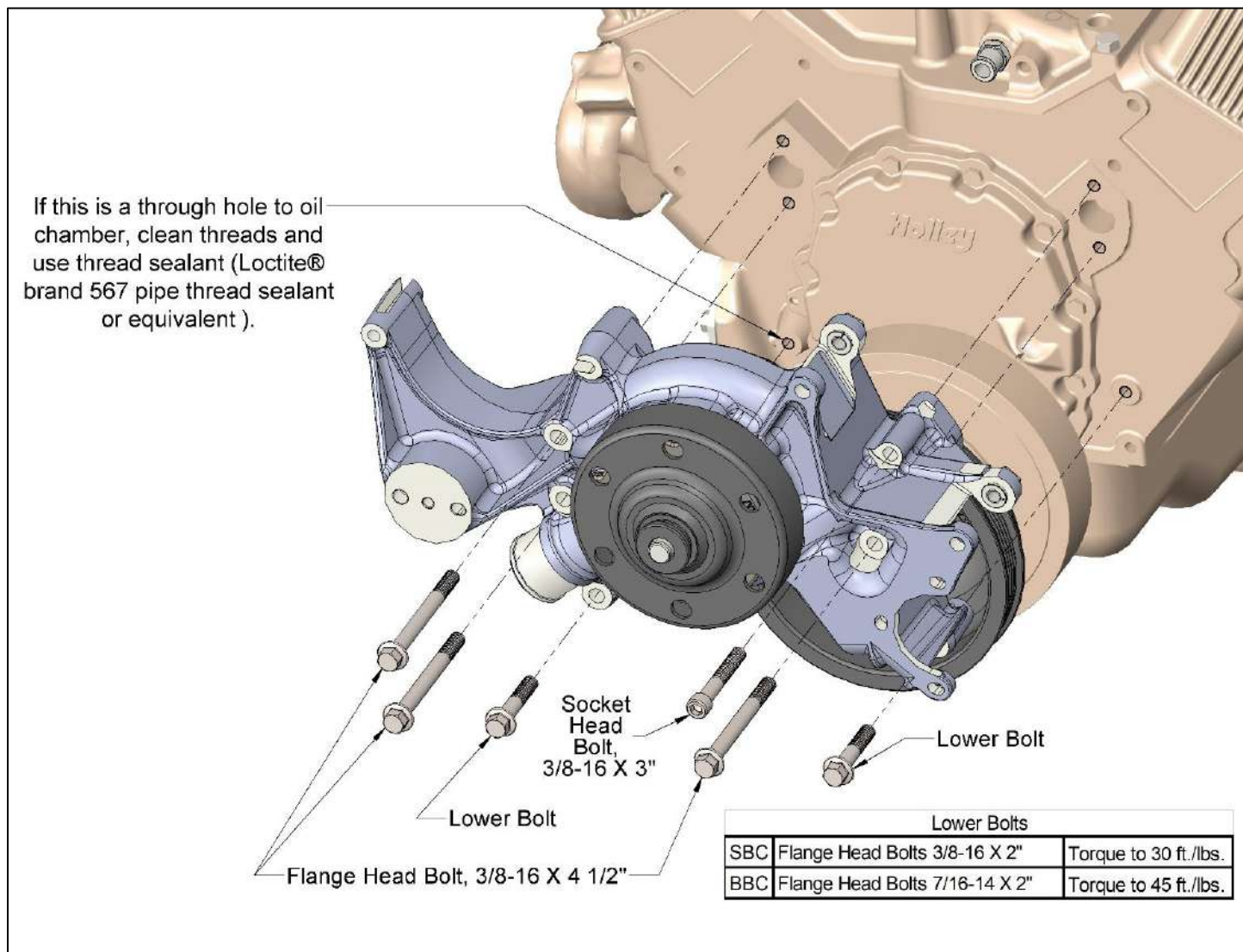

NOTE: Torque 3/8" bolts to 30 ft./lbs. See table for lower bolts torque.

Alternator Installation:

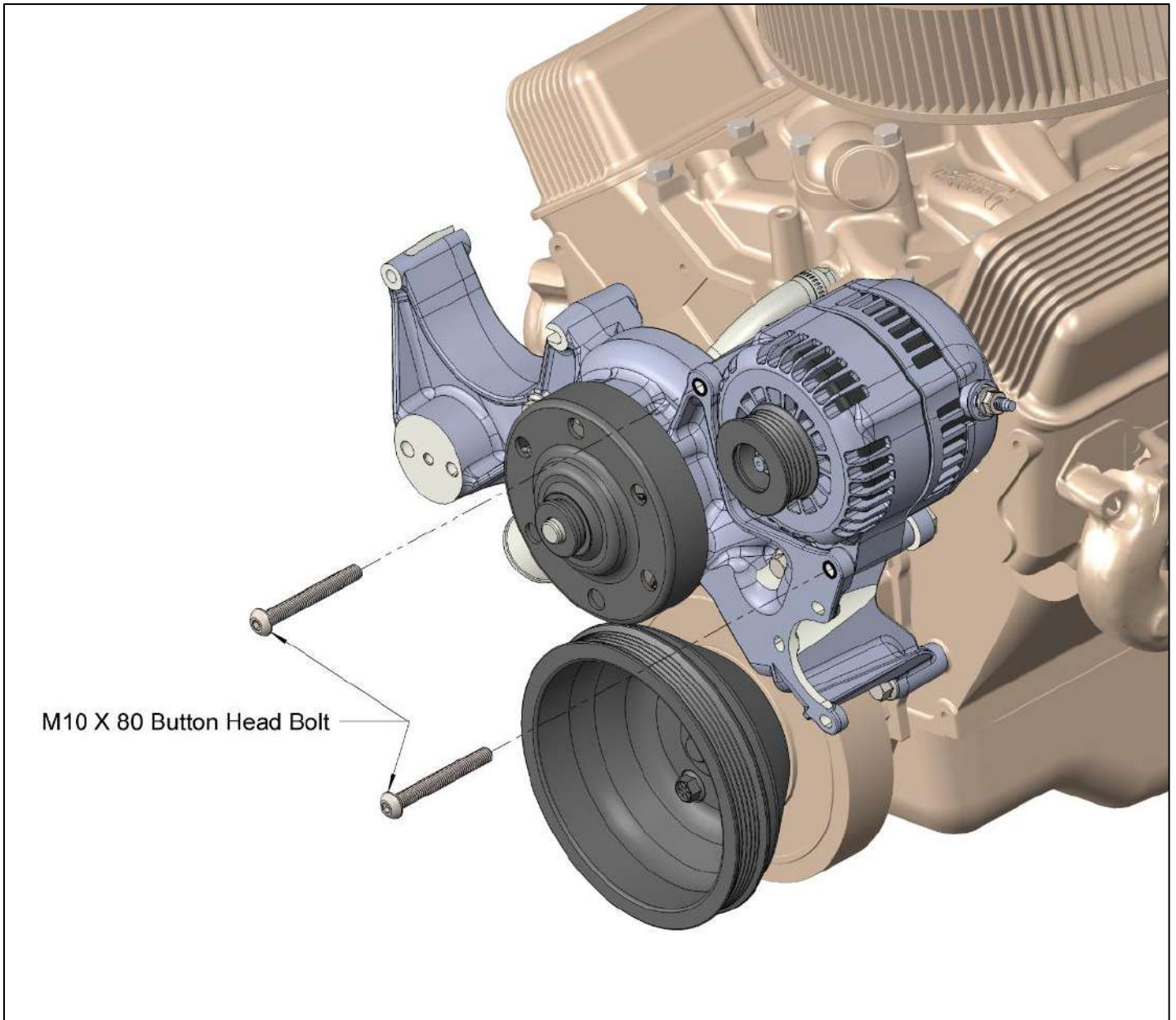

NOTE: Torque M10 bolts to 36 ft./lbs.

ALTERNATOR WIRING: See instructions included with the alternator for wiring directions.

P/S Pump -6 AN Adapter Assembly (for versions with P/S only):

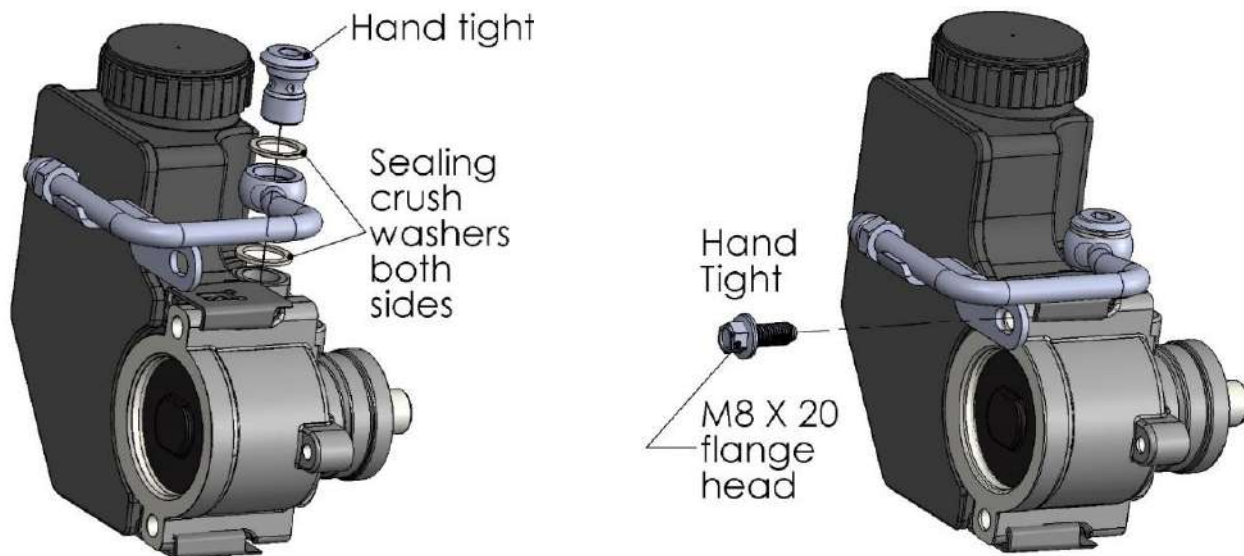

NOTE: After assembly torque M8 bolts to 18 ft./lbs. and banjo bolt to 25 ft./lbs.

P/S Pump Pulley Installation (for versions with P/S only):

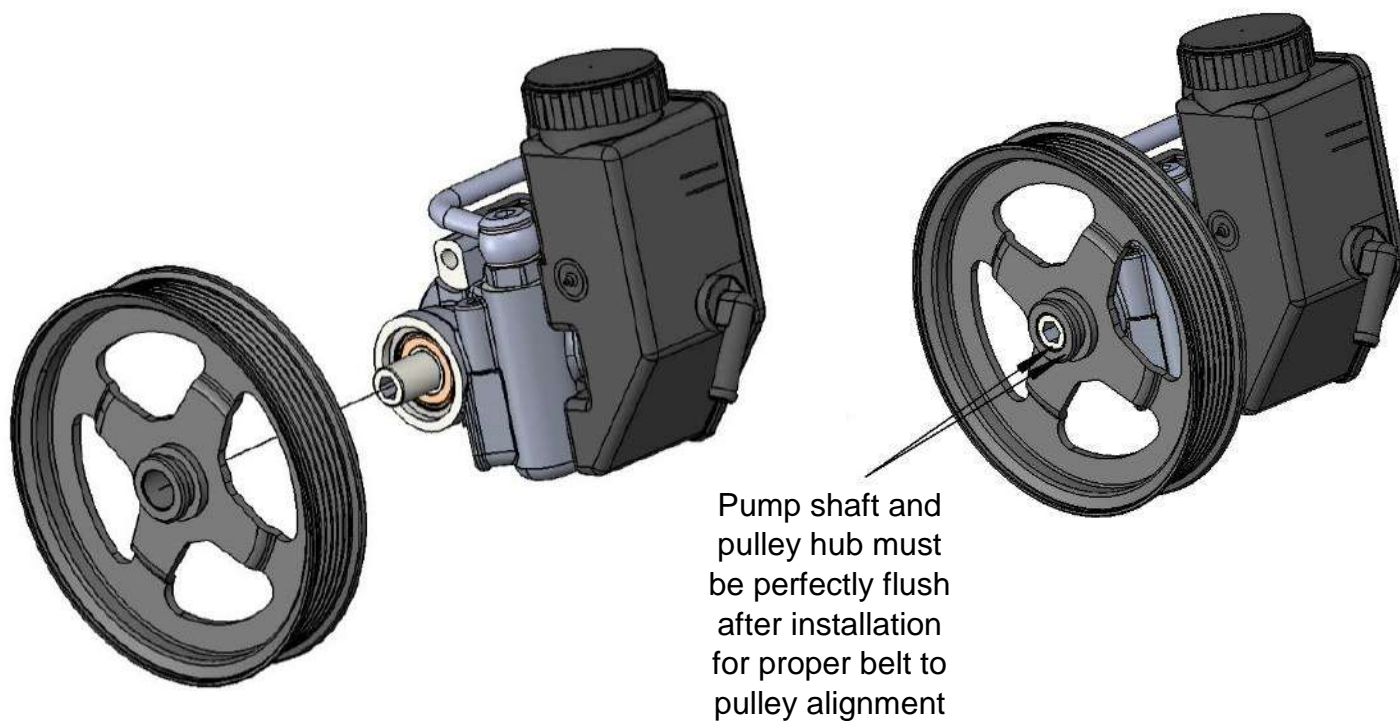

HELPFUL HINT: Pulley installation tools are available for rent at most auto parts stores.

P/S Assembly Installation (for versions with P/S only):

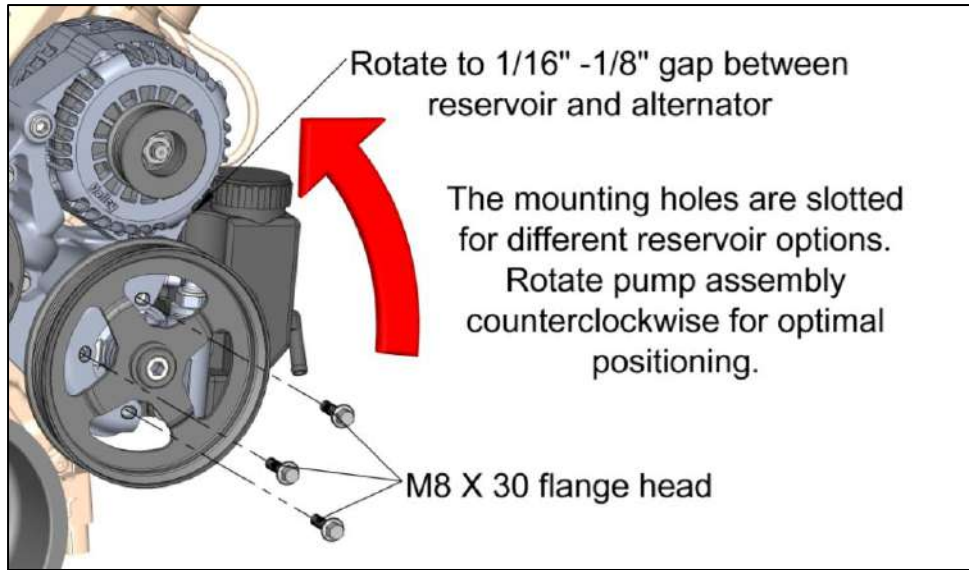

NOTE: Torque M8 bolts to 18 ft./lbs.

HELPFUL HINT: In some applications, the supplied reservoir may interfere with the vehicle. In these cases, a remote reservoir can be utilized. Holley P/S pump P/N 198-100 is best suited for use with remote reservoirs. Also, check the Holley website for additional reservoir alternatives.

A/C Compressor Installation:

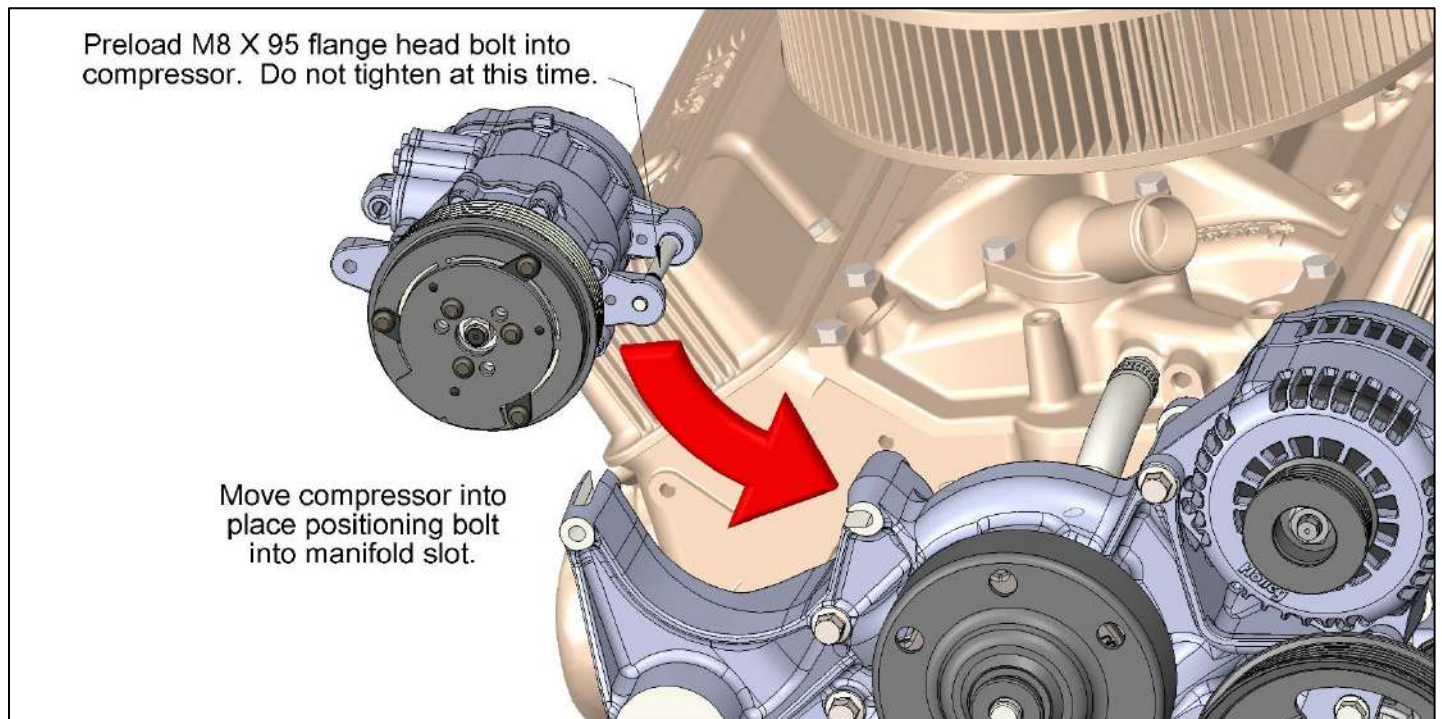

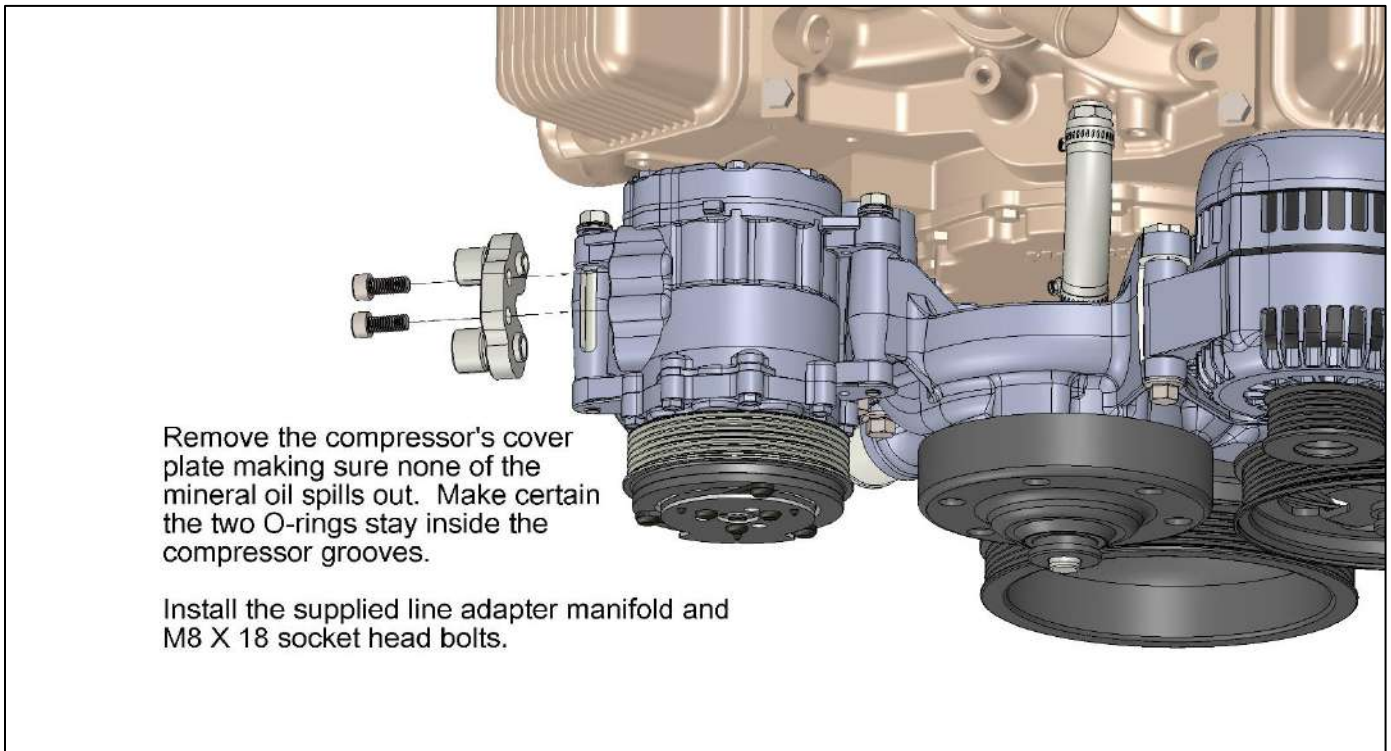
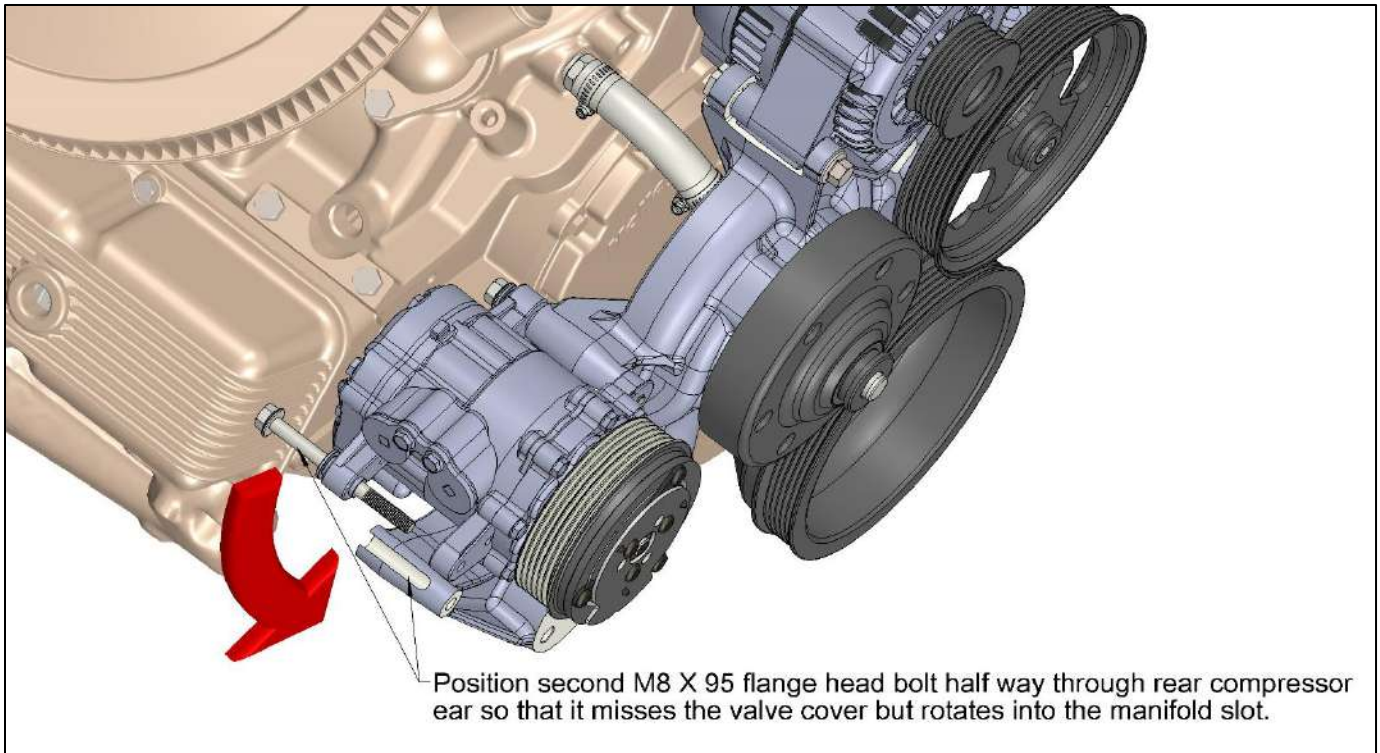

Tensioner Installation:

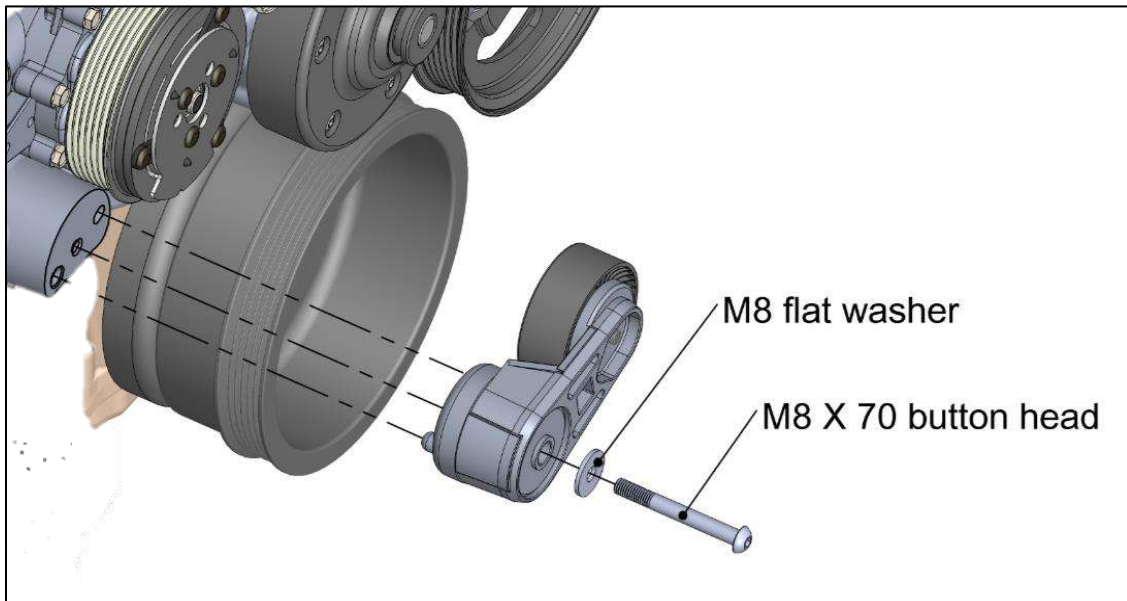

NOTE: Torque M8 bolt to 18 ft./lbs.

Belt Installation:

Route belt around pulleys as shown in red.

For easy installation, route belt onto all grooved pulleys first and then onto the smooth pulleys.

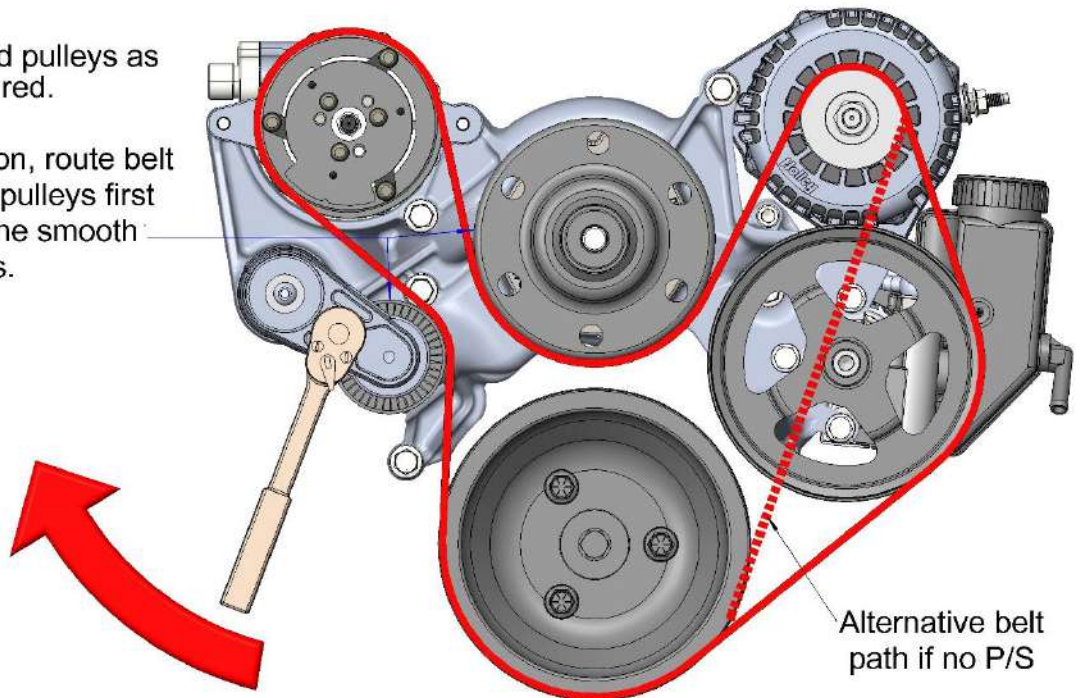

After routing the belt, use a 1/2" square drive wrench to pull the tensioner all the way down and work the belt on from the rear.

Accessory and tensioner covers:

Cosmetic covers are included with most kits. If not included, these can be purchased individually. See instructions included with cover for installation procedures.

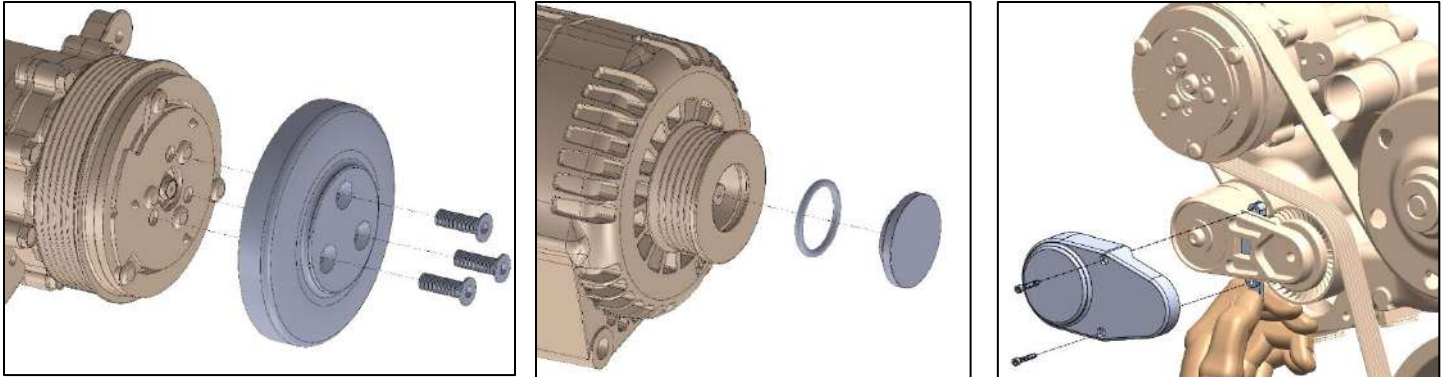

Final inspection:

Before starting the vehicle, confirm all plumbing and wiring is complete, fluids have been added, and the belt is properly fitted to all pulleys. Start the engine. After running for a few minutes but before driving, check for any leaks.