



Assembly, Installation, Operation and Maintenance Instructions

Kit, Base Rail Bracket Part # 31852

(Can be used with 4 Bolt Rails #31323 or 10 Bolt Rails #30686)

Dealer / Installer: Provide a copy of these Instructions to the end user of this product. These Instructions provide important operating and safety information for proper usage of this product. Demonstrate the proper use of the product with the end user. Have the end user demonstrate that they understand the proper use of the product.

End User: Read and follow all instructions included in this manual. Ask your Dealer / Installer for assistance if you do not understand the proper use of the product. Never remove any decals from the product.

WARNING! Never exceed the towing capacity of the tow vehicle.

Center Bolt Kit 32059 (sold separately) must be used when towing with a 26K hitch, Goose Neck, or Maneuvering System.

Base Rails Not Included

Complete Parts List		
ITEM NO.	Description	QTY.
1	DRIVER SIDE BRACKET	1
2	PASSENGER SIDE BRACKET	1
3	5/8" -11 X 3.25" GRADE 5 HEX HEAD BOLT, BLACK	4
4	Ø5/8" X Ø1-3/4" FLAT WASHER, BLACK	4
5	Ø5/8" x Ø1.079" LOCK WASHER, BLACK	4
6	PULL WIRE FOR 5/8"-11 THREADED BOLT	1
7	Ø5/8 ID X Ø1-3/4" FLAT WASHER, CLEAR	4
8	Ø5/8" x Ø1.079" LOCK WASHER, CLEAR	4
9	5/8" -11 GRADE 5 HEX NUT, CLEAR	4
10	5/8"-11 BOLT AND ANTI-ROTATION PLATE	4
11	SPACER PLATE	4
12	1" SPACER TUBE	4
13	CLIP NUT, 5/8" -11	4

Tools Required
3/4" Socket & Wrench
15/16" Socket & Wrench
5/8" Drill Bit
Torque Wrench
Safety Glasses

CAUTION: Do not install mounting rails over plastic bed liners. Plastic bed liners must be cut out of the way. Rails may be installed on spray liners.

NOTE: Consult spray liner installer for recommended curing time before rail installation.

FIGURE 1

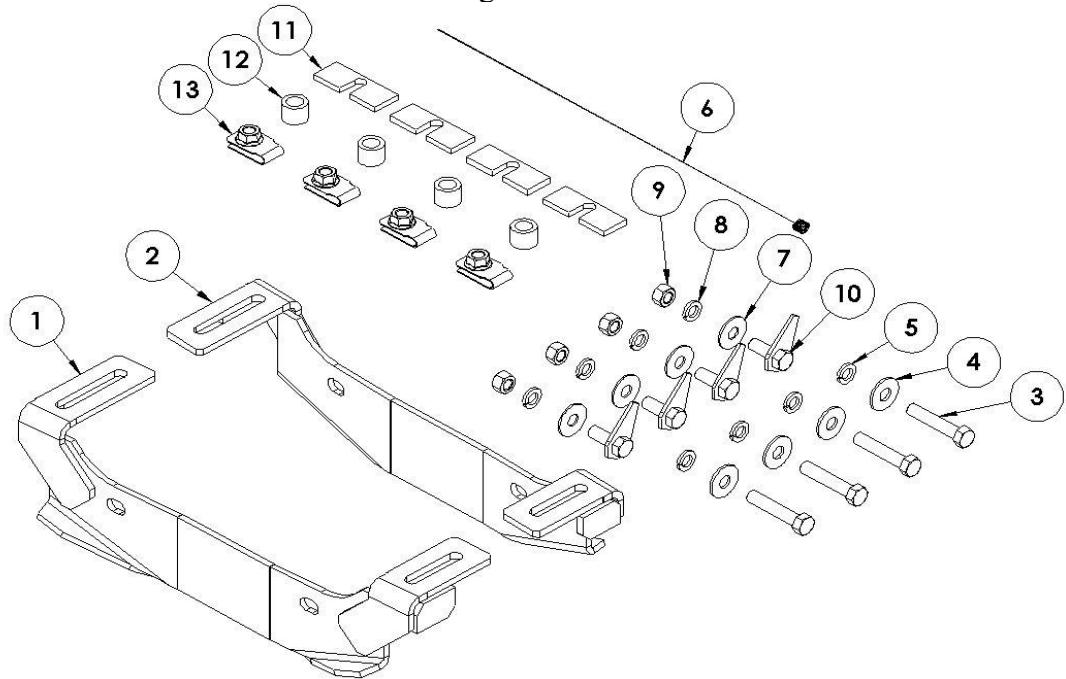

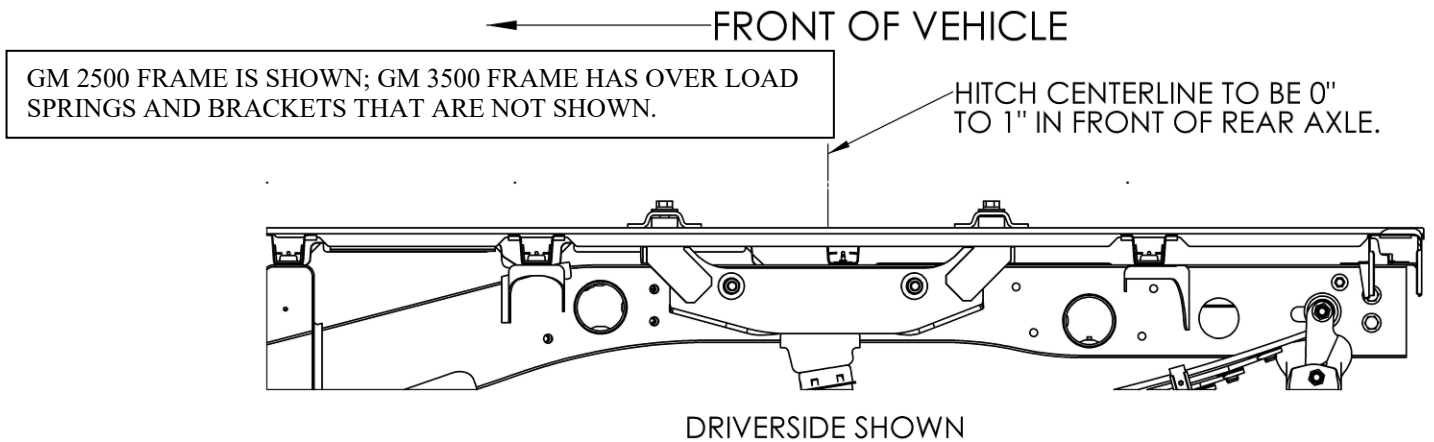
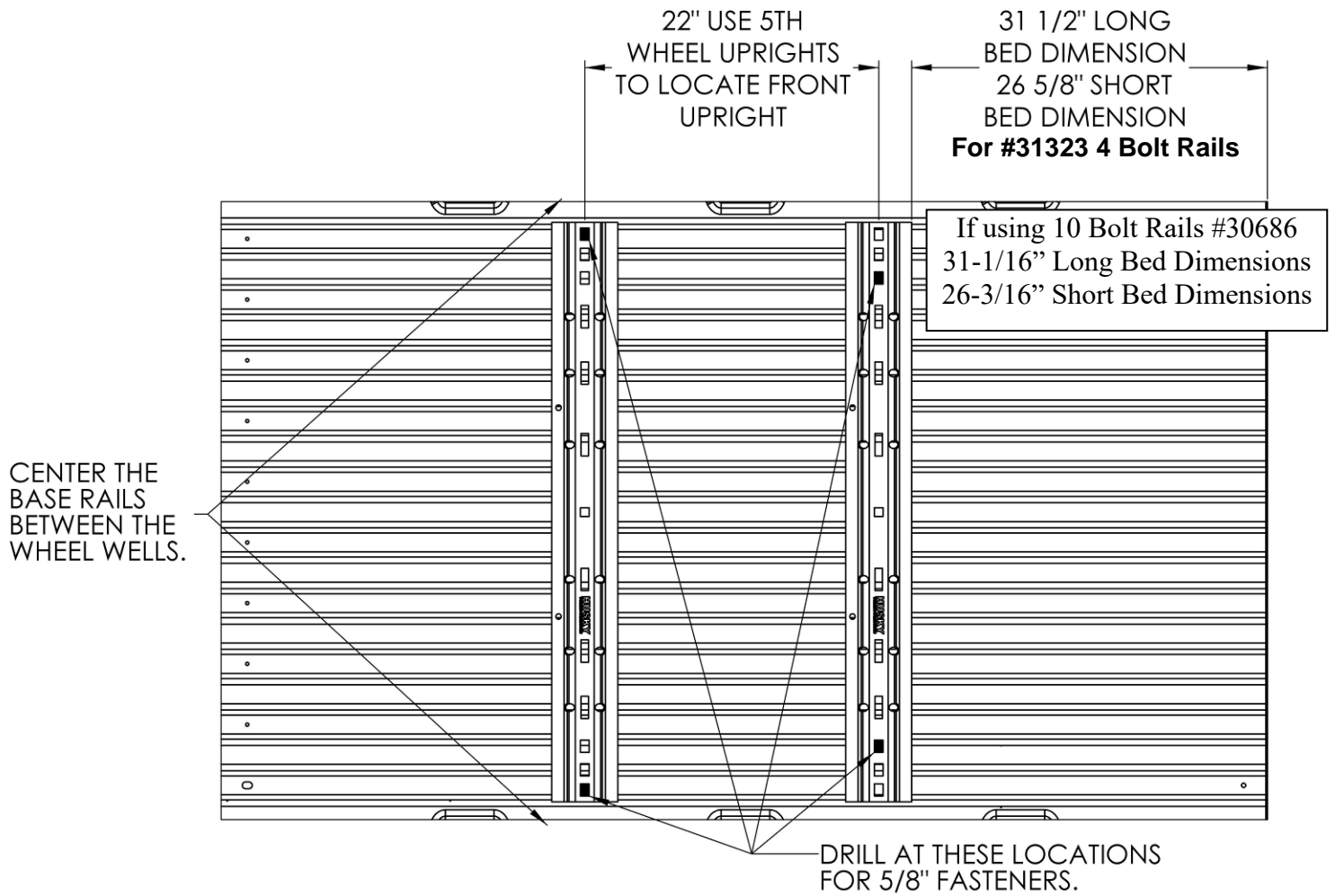

NOTE: Check cab clearance requirements before installing the hitch. The distance from the cab to the hitch centerline is approximately 56" for 8' long beds and 43" for 6.5' long beds.

Figure 1

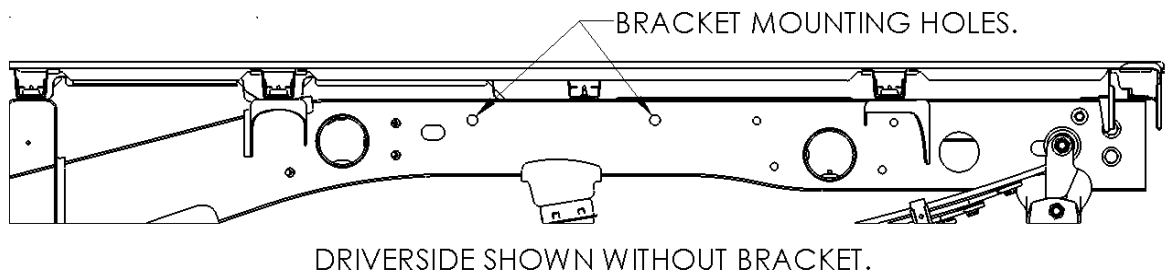

1. Place the two bed rails across the truck bed between the wheel wells. Position the 5th wheel uprights between the bed rails so that the tabs in the base of each upright will fit into the slots in the ends of the bed rails. Secure the uprights in place with the rail hitch pins and hair pins supplied with the 5th wheel installation kit. Securely attach 5th wheel cross member to uprights.
2. Position the bed rail assembly in truck bed as shown in Figure 2. When hitch is correctly positioned in the bed and the bed rails are parallel, mark four attachment points on the truck bed using the 5/8" square holes indicated on the layout in Figure 2. Check below the bed before drilling holes to see that all wiring, brake lines or other obstructions are moved out of the way and will not be contacted by the drill. Move the hitch assembly out of the way and drill four 5/8" diameter attachment holes down through the bed at the previously marked points.
3. Reposition the bed rails in the bed so that the square 5/8" hole in the end of each rail is lined up over the drilled holes. Place item #12 (1" spacer tube) under ends of each bed rail, in line with the drilled holes as shown on Figure 3.

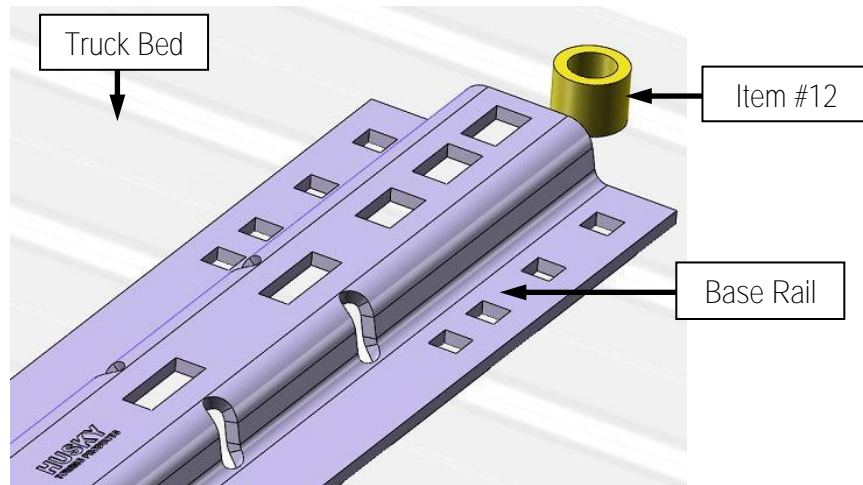

Figure 2

4. If the bed corrugation above the frame is UP, leaving a space above the frame bracket, place item #11 (spacer plate) in the bed, under the base rail as shown on Figure 4.

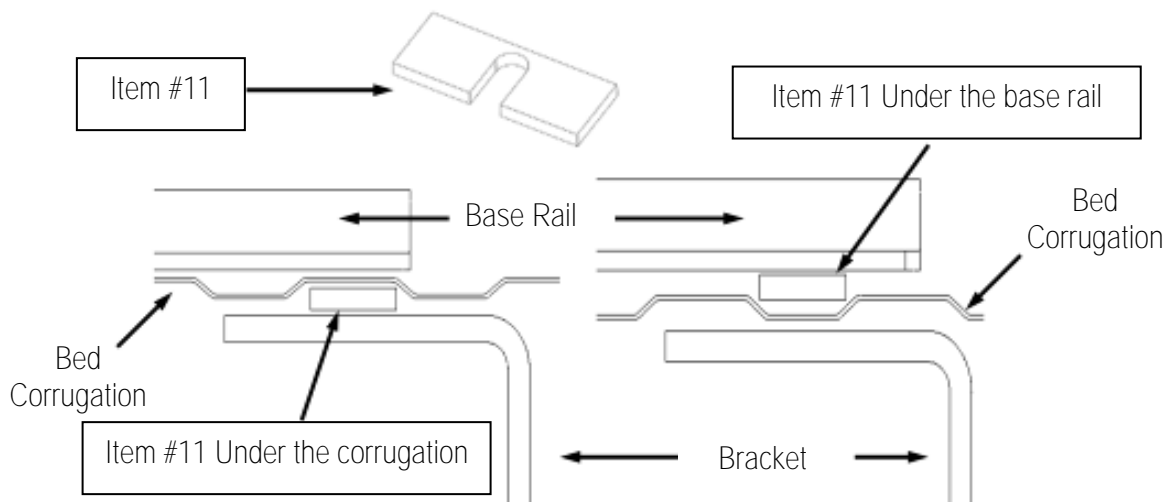
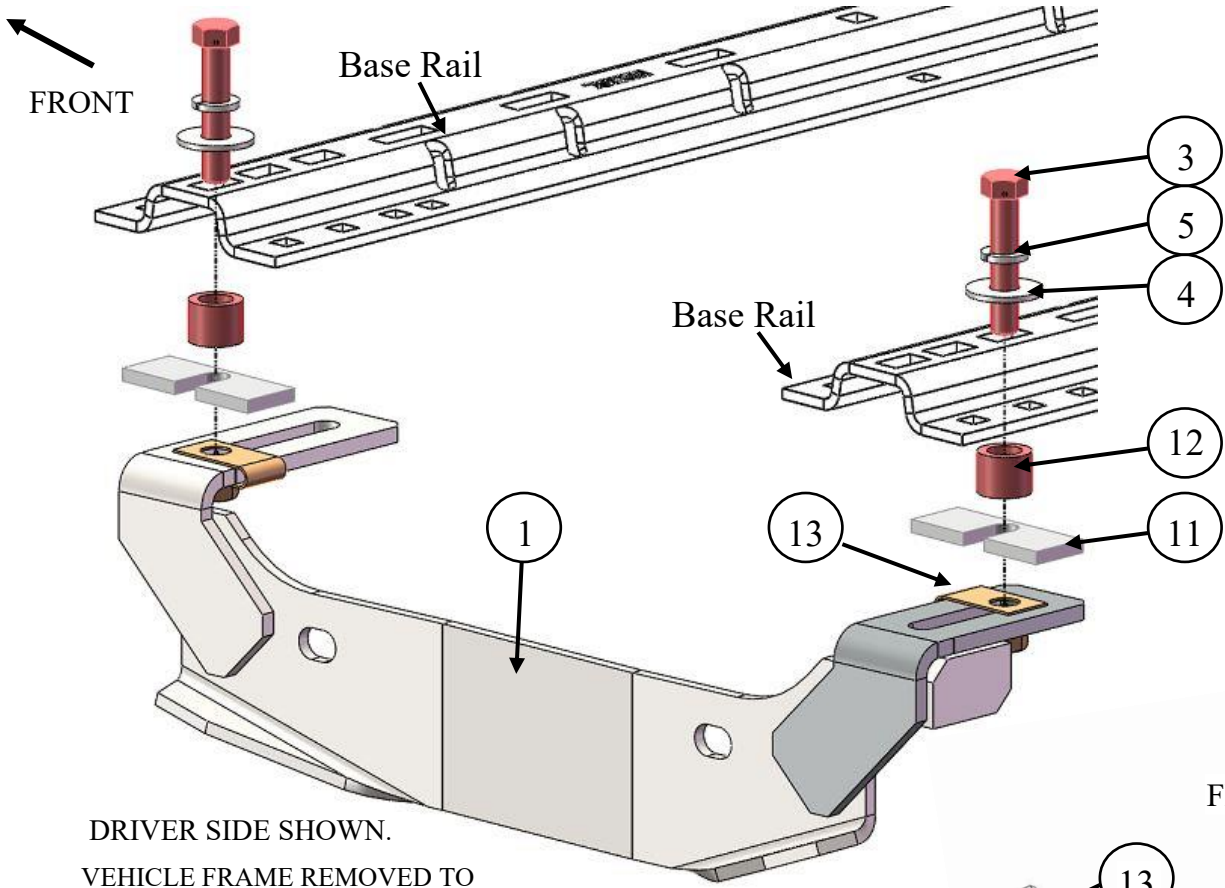

Figure 3

5. If wheel well is lined with a plastic liner that covers the frame, then cut out enough of the liner to expose the frame for bracket installation.
6. Place item #5 (lock washer) and item #4 (flat washer) onto item #3 (5/8" hex bolt) and then insert into 4 drilled holes through the base rails.

- Position item #1 (DS frame bracket) and item #2 (PS frame bracket) up against the outer surface of the truck frame with the mounting tabs positioned over the frame and under the bed and align slots in brackets to 5/8" hex bolts that were installed in step 6. Brackets are marked with a DS for driver side or PS for passenger side to ensure brackets are placed on the correct side of the frame. Thread item #13 (Clip nut, 5/8-11) onto end of item #3 (5/8-11 Hex Head Bolt) loosely for now on all 4 hex bolts. See Figure 4a, 4b &5.



DRIVER SIDE SHOWN.
VEHICLE FRAME REMOVED TO CLARIFY INSTALLATION

Figure 4 a

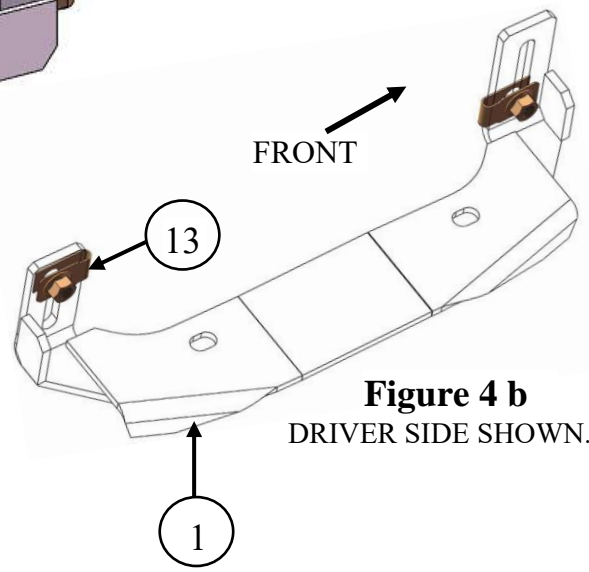
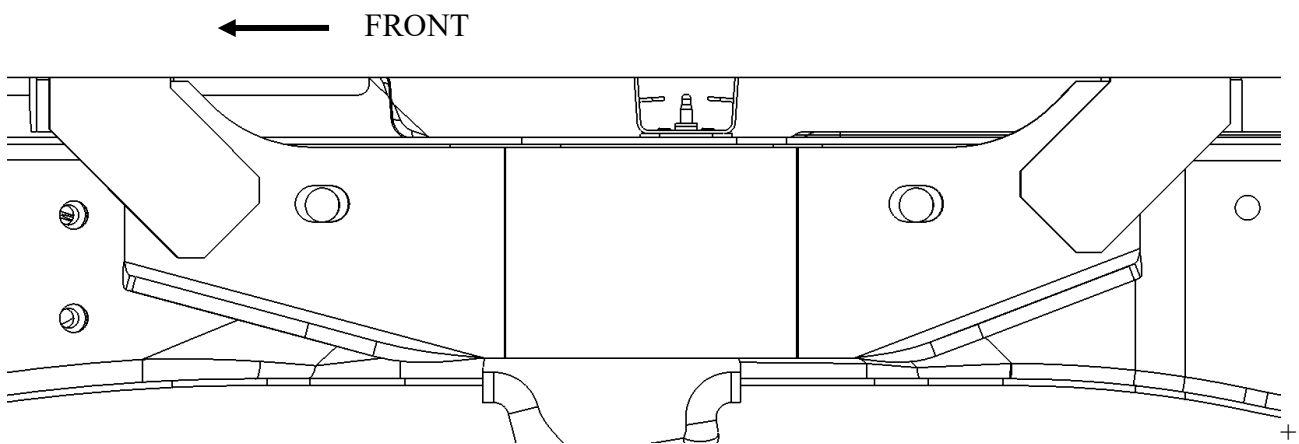

Figure 4 b
DRIVER SIDE SHOWN.

- Brackets should rest in place while proceeding to next step.



DRIVER'S SIDE SHOWN.

9. Install item #10 (5/8 bolt and anti-rotation plate), item #7 (5/8 flat washer), item #8 (lock washer), item #9 (5/8 hex nut) as follows:

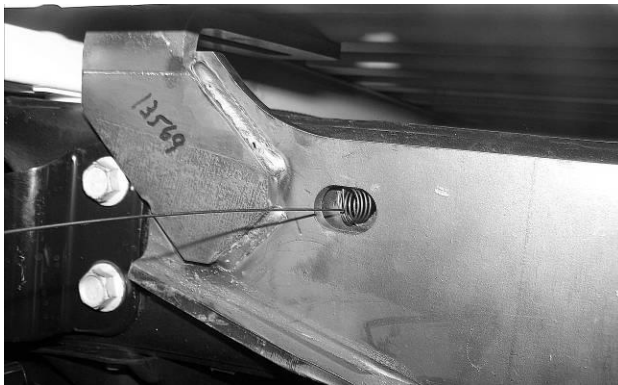

Insert pull wire through slot in bracket.



Guide pull wire coils through hole on inside of frame.



Bend end of pull wire to prevent from going through slot in bracket and hole in frame.

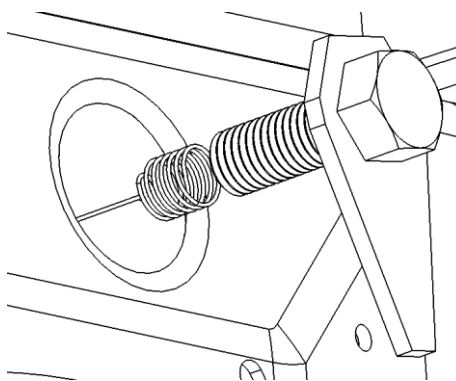

Thread item #10 (bolt and anti-rotation plate) into item #6 (pull wire). Then pull other end of pull wire gently while guiding bolt and anti-rotation plate through hole on inside of frame.



Continue to retrieve pull wire until bolt appears through slot in bracket, carefully un-thread pull wire from bolt and place item #7 (flat washer), #8 (lock washer) and #9 (5/8 hex nut) on bolt and finger tighten only at this time.

10. Repeat step 9 for the remaining slot in the driver side bracket and also for the passenger side bracket.
11. Tighten each 5/8" bed rail attachment bolt to 150 ft-lbs. torque. Failure to tighten bolts as described may result in fastener loss or failure. DO NOT apply torque to the nut portion of the clip nuts (#13). You will DAMAGE it.
12. Check each rail hitch pin for freedom of movement in the bed rail connection before tightening the 5/8" bolts and nuts. Adjust uprights, if necessary, by placing shim 31582 or 30243 between the upright and the cross member to obtain free pin movement. See Figure 5. Shims 31582 & 30243 sold separately

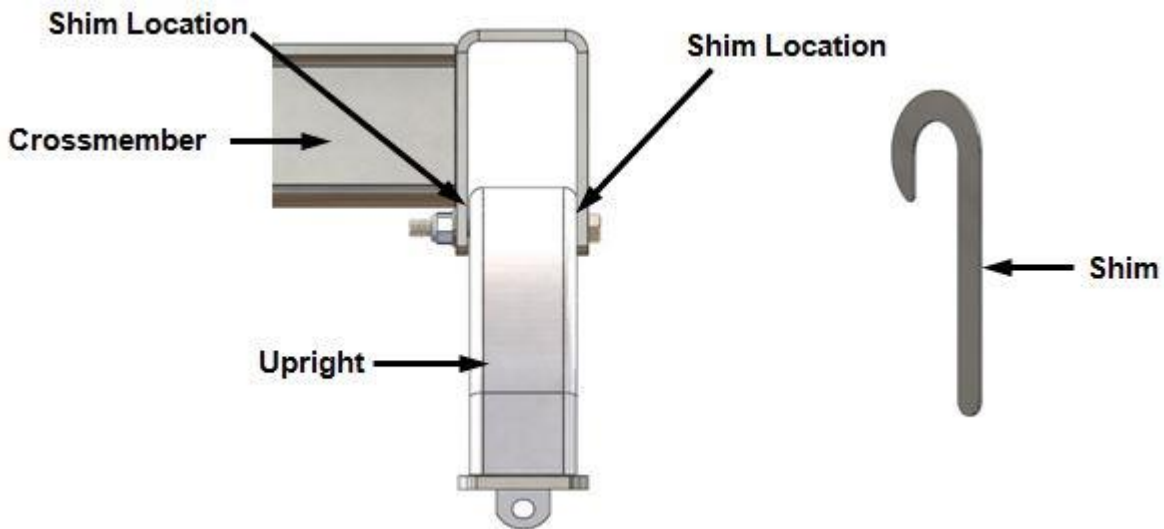

Figure: 5

Warranty Terms:

5 Year Limited Warranty:

This warranty applies solely to Husky 5th Wheel installation Kit manufactured by LKQ Specialty Products Group for Husky Towing Products.

Husky Towing Products and LKQ Specialty Products Group make no guarantees or warranties for products not manufactured by LKQ Specialty Products Group. Such products are covered solely under any applicable warranty of the manufacturer. It is always recommended that the operating instructions and guarantee instructions provided by the manufacturer are followed.

LKQ Specialty Products Group warrants its products to be free from manufacturing and material defects to the original purchaser for the length of warranty stated above from the date of retail purchase. If any products are found to have a manufacturing or material defect, the product will be replaced or repaired at the option of Husky Towing Products and LKQ Specialty Products Group with proof of purchase by the original purchaser. The original purchaser shall pay all transportation and shipping costs associated with the return of the defective product and the defective product shall become the property of LKQ Specialty Products Group.

The Warranty applies to LKQ Specialty Products Group products used for individual and recreational purposes. Commercial usage of the LKQ Specialty Products Group products limits the warranty to 90-days from date of purchase.

The Warranty applies only to LKQ Specialty Products Group products which are found to be defective in manufacturing or material. This warranty does not apply to normal wear and tear of the finished placed on LKQ Specialty Products Group products.

Husky Towing Products and LKQ Specialty Products Group are not responsible for any labor costs incurred for removal or replacement of the defective product.

Husky Towing Products and LKQ Specialty Products Group are not responsible for repair or replacement of any product under the limited warranty where the product was improperly installed, misapplied, altered, abused, neglected, overloaded, misused or damaged as a result of an accident, including any use of the product not in accordance with all product operating and safety instructions.

Without limiting the generality of the foregoing, Husky Towing Products and LKQ Specialty Products Group shall under no circumstances be liable for any incidental or consequential loss or damage whatsoever arising out of, or in any way relating to any such breach of warranty or claimed defect in, or non-performance of the products. Some states do not allow the exclusion or limitation of incidental or consequential damages, so the above exclusion or limitation may not apply to you.

This limited warranty gives you specific legal rights, and you may also have other rights that vary from state to state.