

**2021 F-150  
WITH OUT FENDER FLARES****FRONT MUD GUARD INSTALLATION INSTRUCTIONS**

*Install Paint Protection Film before mud guards (see other side)  
Please read instructions thoroughly before installation.*

**Tools Required**

- 6mm Socket / Driver

**Package Contents**

- Front Mud Guards
- Paint Protection Film (1 set)
- Clips X 2
- Instruction Sheet

***Determine which mudguard you have by locating the part number molded in the mounting flange (5852 DS and 5852 PS).***

1. Dry fit the mud guards to make sure the fit is correct for your truck.
2. Clean and degrease the mud guard location area on the fender before installation.
3. Install the paint protection film and wipe the mounting area dry (film installation instructions on back of this page).
4. Remove existing fasteners from locations A and B.
5. Peel red protective cover from the 3M adhesive tape that is attached to the mudguard.
6. Loosely attach mud guards to front fender with factory fasteners at locations A and B, check fit and make sure mud guard is parallel to ground before tightening. Be sure to press firmly on the area with the 3M adhesive tape to make sure adhesive is set.
7. Install clips where shown.

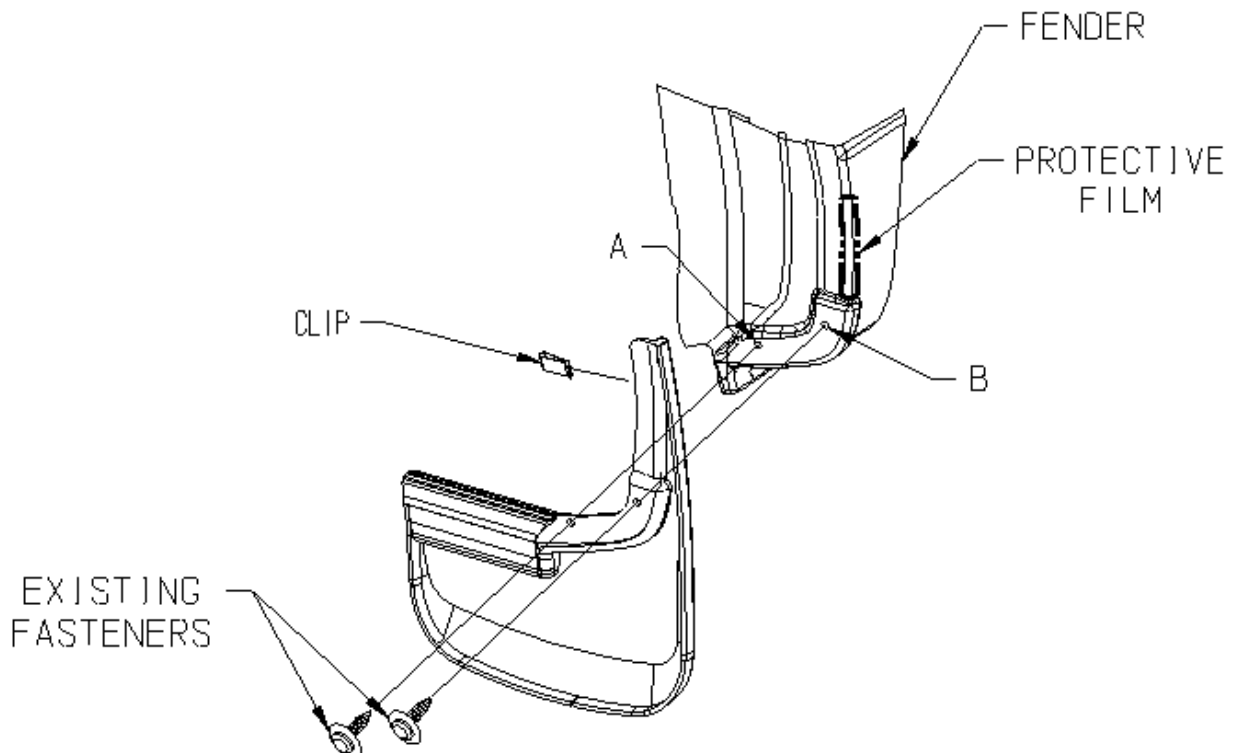

**PAINT PROTECTION FILM - INSTALLATION INSTRUCTIONS**

**NOTE:** *The Paint Protection Film is a precut template of film used to protect the mud guard mounting surfaces of your fenders against wear. The templates (left and right side) can be removed from the backing liner by folding the liner at the center cut of the template, separating the film sides and peeling the film templates from the backing liner.*

1. Position mud guard on fender to indicate placement location of paint protection film.
2. Clean the placement area of fender with a clean cotton cloth and a petroleum distillate based cleaner such as DuPonts Prep-Sol Brand Solvent Cleaner or 3M Brand Adhesive Cleaner and dry.
3. Mix a wetting solution of 1 pint of water with 4 drops of liquid dishwashing detergent.
4. Mark correct position of film by placing mud guard against fender. **Make sure film extends beyond edge of mud guard contour a minimum of an 1/8".**
5. Remove protection film from liner and flood adhesive side of film with wetting solution (use a spray bottle or sponge).
6. Thoroughly wet film placement location of fender with wetting solution.
7. Position the adhesive side of film on fender and flood with wetting solution.
8. Check location of film with mud guard and reposition as necessary.
9. Using a sponge, squeegee any air bubbles and wrinkles from film.
10. Allow film to dry before installing mud guard.

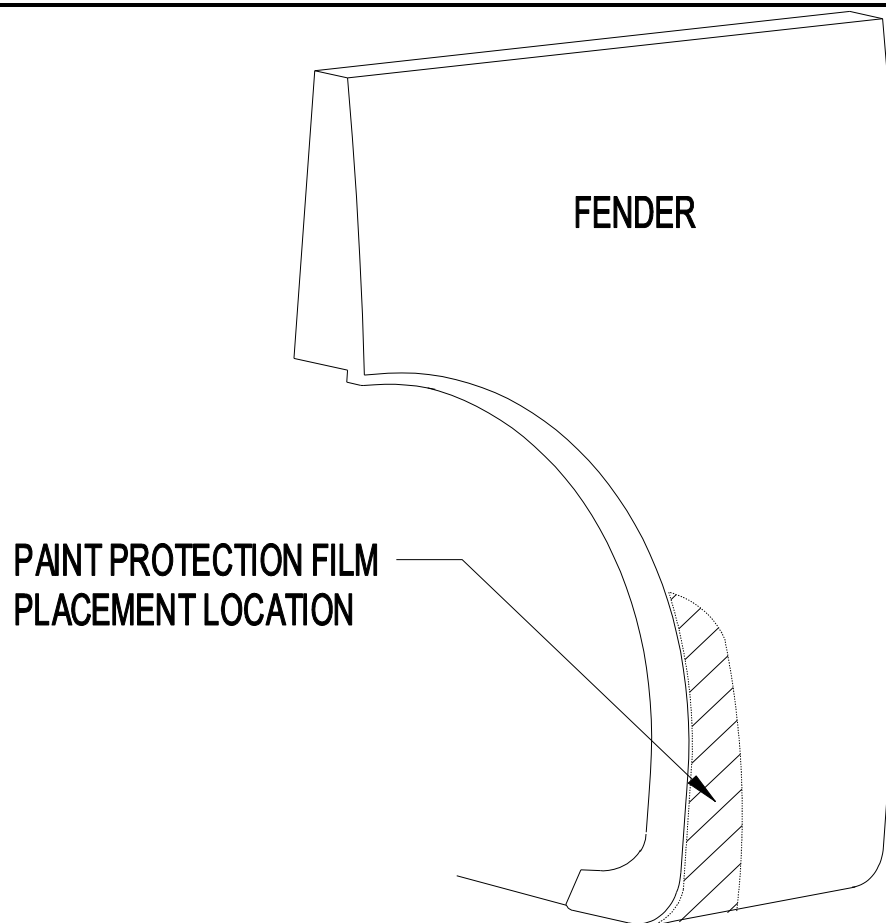

**REAR MUD GUARD INSTALLATION INSTRUCTIONS**

*Install Paint Protection Film before mud guards (see other side)  
Please read instructions thoroughly before installation.*

**Tools Required**

- Phillips Screwdriver

**Package Contents**

- Rear Mud Guards
- Paint Protection Film (1 set)
- Spring Clips X 2
- U-Clips X 2
- #10 SEM Screw X 2
- Instruction Sheet

***Determine which mudguard you have by locating the part number molded in the mounting flange (5952 DS and 5952 PS).***

2. Dry fit the mud guards to make sure the fit is correct for your truck.
3. Clean and degrease the mud guard mounting location area on the fender before installation.
4. Install the paint protection film and wipe mounting area dry (film installation instructions on back of this page).
5. Remove existing tree fastener from location A as shown
6. Peel red protective cover from the 3M adhesive tape that is attached to the mudguard.
7. Attach mud guard to rear fender with #10 SEM screw at location A as shown. Use the included U-Clip on the back side of the fender as a nut. Check fit and make sure mud guard is parallel to ground before tightening. Be sure to press firmly on the area with the 3M adhesive tape to make sure adhesive is set.
8. Install Spring Clips where shown.

