



**RAM 3500 DUALY
WITH FENDER FLARES**

REAR MUD GUARD INSTALLATION INSTRUCTIONS

*Install Paint Protection Film before mud guards (see other side)
Please read instructions thoroughly before installation.*

Tools Required

- 8mm Socket / Driver

Package Contents

- Rear Mud Guards
- Paint Protection Film (1 set)
- Spring Clips (2)
- Instruction Sheet

Determine which mudguard you have by locating the part number molded in the mounting flange (5907 DS and 5907 PS).

1. Clean and degrease the mud guard location area before installation.
2. Install paint protection film (instructions on back of this page)
3. Remove existing fasteners from locations A and B
4. Peel red protective cover from the 3M adhesive on the mudguard.
5. Attach mud guard to rear fender with factory fasteners at locations A and B, check fit and make sure mud guard is parallel to ground before tightening. Be sure to press firmly on the area with the 3M adhesive tape to make sure adhesive is set.
6. Install spring clips, positioning as shown. The spring clips fit over the front of the mud guard and behind the sheet metal, securing the mud guard in position.

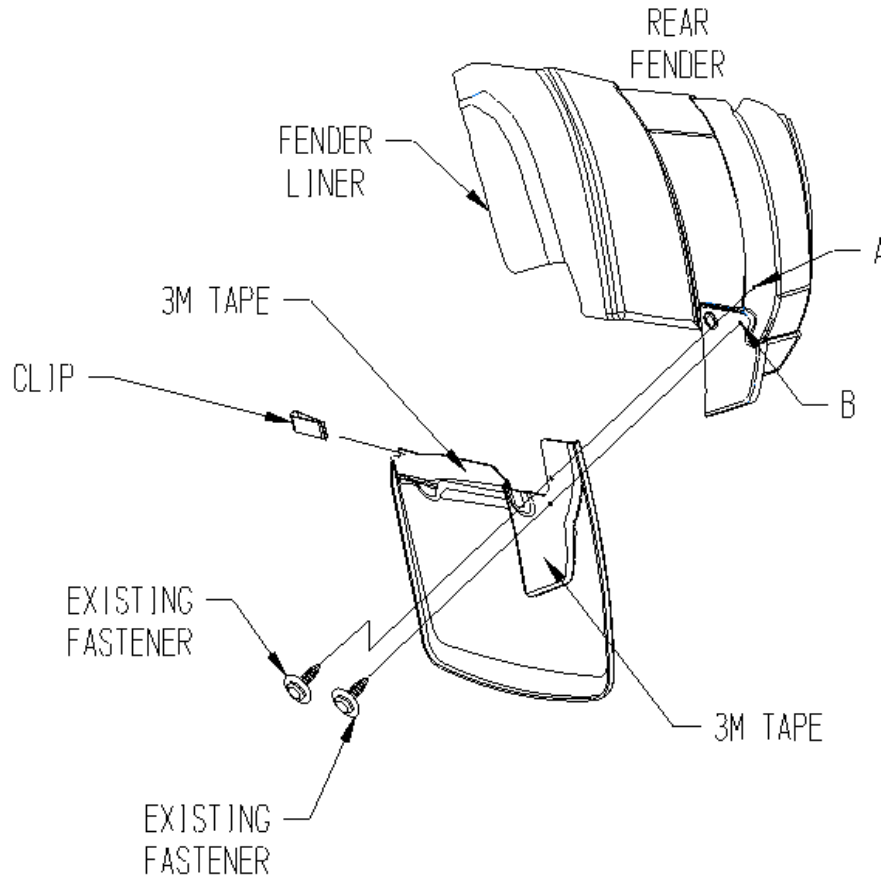

PAINT PROTECTION FILM - INSTALLATION INSTRUCTIONS

NOTE: *The Paint Protection Film is a precut template of film used to protect the mud guard mounting surfaces of your fenders against wear. The templates (left and right side) can be removed from the backing liner by folding the liner at the center cut of the template, separating the film sides and peeling the film templates from the backing liner.*

1. Position mud guard on fender to indicate placement location of paint protection film.
2. Clean the placement area of fender with a clean cotton cloth and a petroleum distillate based cleaner such as DuPonts Prep-Sol Brand Solvent Cleaner or 3M Brand Adhesive Cleaner and dry.
3. Mix a wetting solution of 1 pint of water with 4 drops of liquid dishwashing detergent.
4. Mark correct position of film by placing mud guard against fender. **Make sure film extends beyond edge of mud guard contour a minimum of an 1/8".**
5. Remove protection film from liner and flood adhesive side of film with wetting solution (use a spray bottle or sponge).
6. Thoroughly wet film placement location of fender with wetting solution.
7. Position the adhesive side of film on fender and flood with wetting solution.
8. Check location of film with mud guard and reposition as necessary.
9. Using a sponge, squeegee any air bubbles and wrinkles from film.
10. Allow film to dry before installing mud guard.

