

INLAND EMPIRE DRIVELINE®

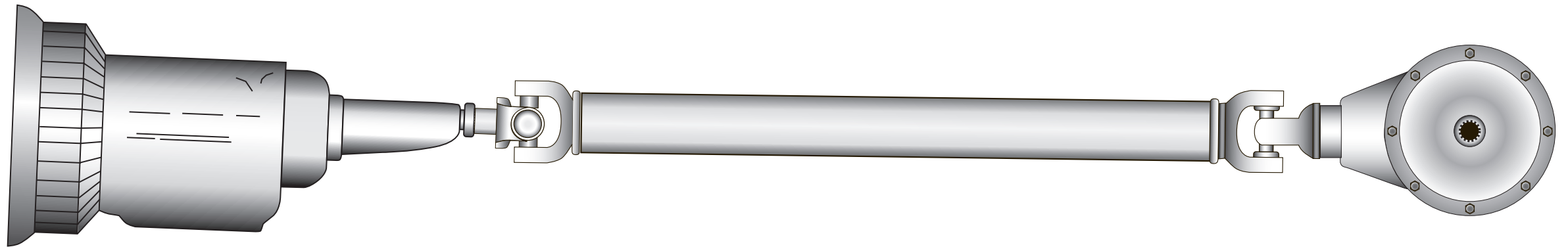

POWER TRAIN SET UP

by
Greg Frick

POWER TRAIN SET UP

This booklet concerns the placement of power train components in the chassis. The engine/transmission, the third member and the drive shaft must be installed to work in harmony if driveability is your goal. The booklet has four sections. The first explains why harmony is necessary, the second what needs to be done to achieve harmony, the third gives examples of how to plan for smooth operation, the fourth how to measure for drive shafts. Any section may be read alone but each will be more clear if read in sequence.

WHY IS POWER TRAIN PLACEMENT CRITICAL?

Engines produce power. Transmissions and third members modify power. Drive shafts deliver power. While this is obvious, the devil is in the details of their placement and relation to each other. Of the four components, only the drive shaft is free to move as it rotates. Drive shafts allow for distance changes between the transmission and third member, correct any misalignment between the two and rotate at engine speed or higher. With the freedom comes instability and sensitivity.

The first consideration in drive shaft selection is length. Length is fundamental because of harmonics. Some will remember the television ad showing a singer shattering a glass with a single note.



FIG. 1

That note was a harmonic of the glass' natural frequency, the one you hear when you tap the glass. Energy from that note built up in the glass, exciting the natural frequency 'til the strength of the glass was overwhelmed and it exploded. The same thing happens to driveshafts.



FIG. 2

Drive shafts explode at an RPM called Critical Speed. In theory Critical Speed depends on shaft length, weight, diameter and RPM. In the real world Critical Speed is lowered by u-joint angles, shaft mounts and even the engine's firing. Keeping safely away from critical speeds affects decisions about drive shaft tube diameter and the decision to move to two-piece shaft sets to add support when bridging long spans.

U-joint angles affect critical speed. If you look at a dinner plate it'll look round. If you pick it up and tilt it, it'll look elliptical. This ellipse is the way the drive shaft "sees" the universal joint. For the joint to rotate through the ellipse it must speed up and slow down twice per revolution. As the angle of operation increases the abruptness of the speed change also increases.

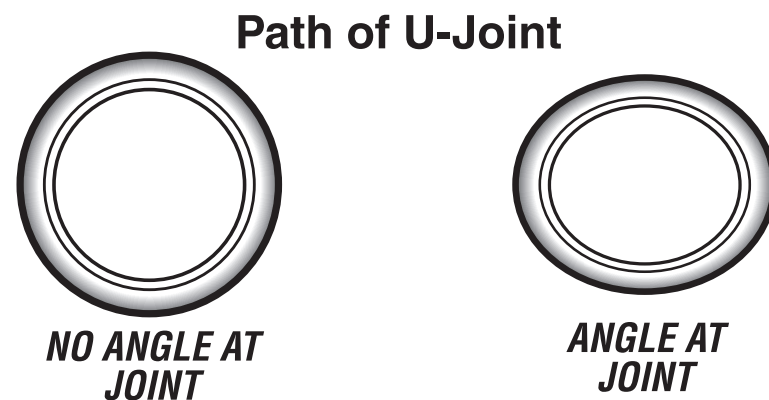

FIG. 3

Smooth engine power passing through a u-joint angle becomes pulsating power because of these speed changes. For smooth roadability the pulsations must be eliminated by an equal but opposite u-joint angle at the pinion end. Failure to cancel the pulsations results in vibration, premature ring and pinion wear and broken axles. The two per revolution pulsations also excite the natural frequency of the shaft resulting in a shudder at the "half critical" RPM. Keep in mind that the drive shaft is always pulsating and that bigger working u-joint angles result in greater shaft pulsations and more shaft instability.

Another factor affecting critical speed and smooth operation is engine torsional vibration. The smooth power assumed above isn't actually smooth. Every time a piston fires it accelerates the crankshaft. In a V-8 this happens 4 times per revolution and in a V-6 three times per revolution. These forces are fed into a drive shaft that is already unstable because of its pulsating travel. An overdrive transmission amplifies and reduces the frequency of the torsionals and feeds even more energy into the drive shaft because of the additional torque required at the lowered operating RPM.

Lastly there is the ring and pinion ratio. The gear set generates a frequency that is absorbed by its housing but is also transmitted to the drive shaft and to the frame via the mounts. While not often noticeable, vibrations produced by rear end frequencies can be very difficult to diagnose.

All of the activity described above is going on all the time in your car's drive shaft. The behavior of the drive shaft due to these factors is independent of the shaft's quality. A poorly made or poorly balanced shaft will contribute additional forces to the mix but all shafts are subject to the same physics. Consequently, serious thought in the planning stage will pay off in reduced frustration, fewer modifications, and smoother cruising later.

HOW TO PLAN YOUR LAYOUT

Before buying anything draw a sketch of your project. Draw your project car as you want it to look running down the road with the tires and wheels to scale. Show this sketch to the chassis and body manufacturers you are considering. Ask each of them whether they think your dream stance is both attainable and drivable. Remember, they have done this many times and it is best to listen to what they have to say. If you are building on an OEM chassis do the drawing and read on. The trap here is that part of the frame or the body will occupy a place where the

engine, transmission, driveshaft or rear end needs to be. It is important to keep in mind that physics will ultimately win all confrontations with style.

Setting the chassis on stands as it is to run down the road cannot be emphasized enough. All angles and all placements are relative to the ground (horizontal) and not to the chassis. If you want, or your chassis builder built in a 3-degree rake, the chassis must be set on the stands with the 3-degree rake or every weld you make and every hole you drill will be in the wrong place. If you want the car level but your chassis builder builds in a 3-degree rake, you are already in deep, angular trouble. Talk, ask, think, and talk some more before buying anything.

Engines are set in the frames at 3 degrees downward angle to the rear. This is virtually a world standard for engine placement and is the basis for intake manifold construction. It is this fixed installation that determines the possible. To arrive at equal and opposite u-joint angles the pinion must be set parallel to the crankshaft.

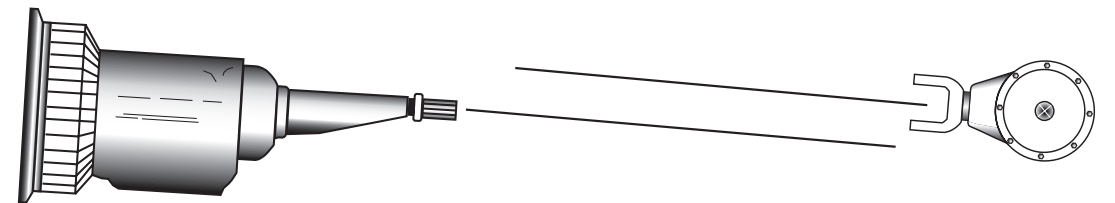
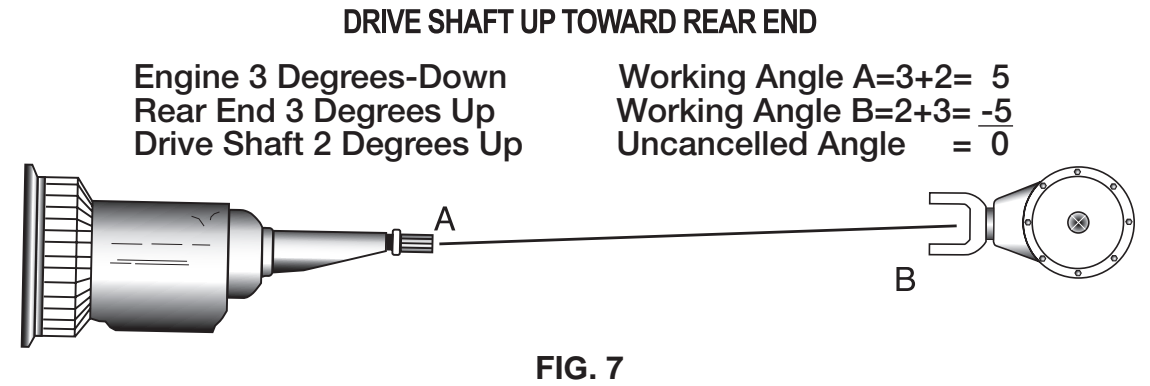
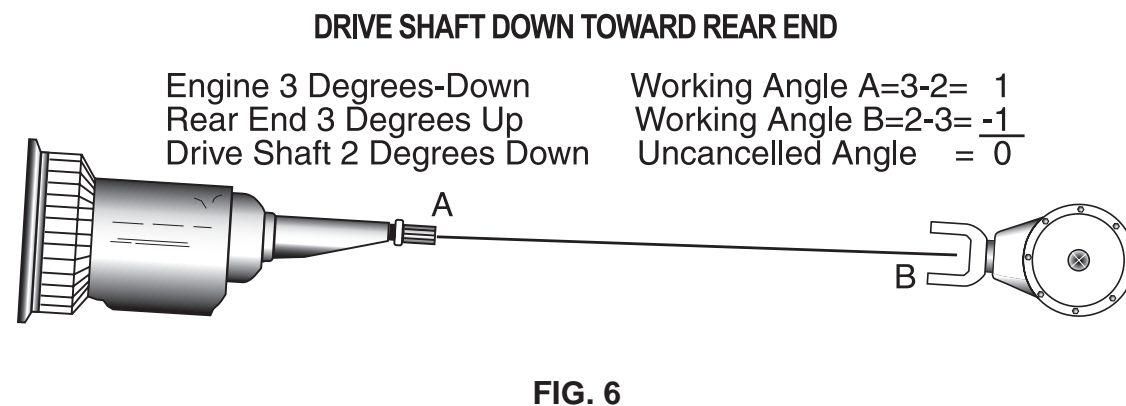
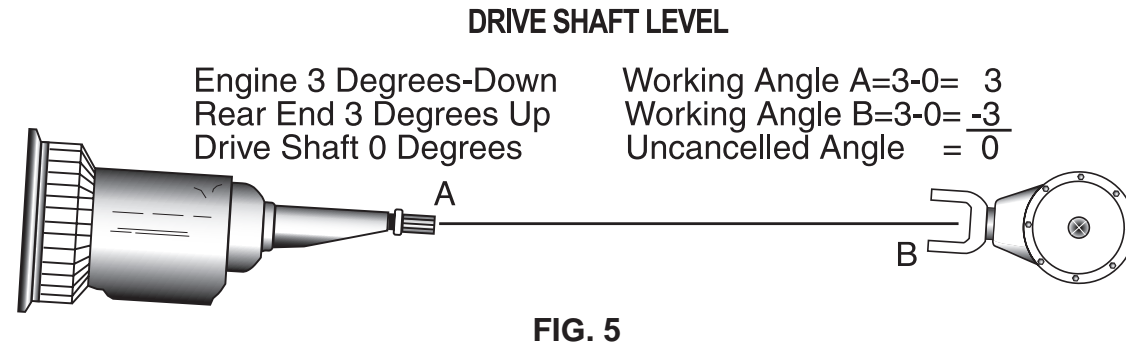

FIG. 4

So far, so good.

At this point you may find the drive shaft to be level, going down or going up toward the pinion. Figures 5, 6 and 7 show these variations. As you see, the objective is to add the angles up to equal zero. In street rods it is only the situation in figure 7 that causes problems. Because we are married to the 3-degree down engine we have to ADD the uphill drive shaft angle to the 3 degrees to get our working angle.



A good way to visualize these variations is with a straw or pencil. Hold the straw between your index fingers and hold your index fingers parallel. By starting with the straw level and raising or lowering one finger, it is easy to see the effect on the angle between the straw and your finger.

Universal joints are designed to have their maximum life operating at 5 degrees or less. Experience leads us to believe that street rodders can feel angles sharper than 3 degrees as a general "busyness" in the car. As working angles increase, more energy is fed into the drive shaft and still more "busyness" is felt. Often other parts of the car, like the rear view mirror or gearshift lever, will vibrate in resonance to this "busyness." In the worst cases big angle cars are not drivable at all on the highway.

Conversely, as working angles approach zero, smoothness improves. Reduction of joint angles reduces shaft pulsation and promotes stability. U-joint life is not substantially affected because there is almost always an angle produced by pinion offset.

Measuring the engine and pinion angles before welding motor mounts or rear end mounts in place is a straightforward process. For the engine, place your angle finder on a machined surface such as the starter mount. If no machined surfaces are available use the casing of the starter motor itself.



FIG. 8

Stamped pans, carburetor mounts and transmission tail shafts can give false readings resulting in some uncanceled u-joint angle that can be the cause of vibration. Turning the pinion yoke to horizontal

and placing your angle finder vertically on the yoke ear easily measures pinion angle.

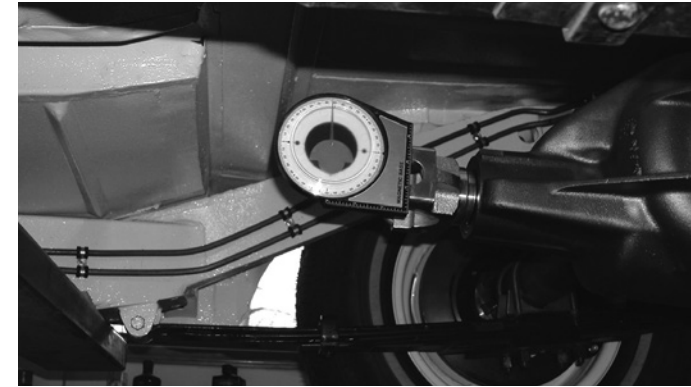

FIG. 9

Pinion angle set up continues to be a controversial subject. It is controversial because everyone's opinion is correct to some extent. For example, a drag race car is set up differently than a circle track car. Each of these is set up differently from a street rod intended to run the highways.

Always remember what you plan to do with the car when it is finished. The goal of the street rodder should be smooth operation under all conditions and this is achieved by equal variation on both sides of a perfect pinion angle.

HOW TO MEASURE FOR DRIVE SHAFTS-ONE PIECE

You are ready to measure for your drive shaft when your car has its engine, transmission and third member in place. The body need not be on the chassis at this time. If you wish to verify that body weight will not affect the ideal measurement, distribute enough friends around the frame rails and measure again. If there is a difference note it and send it along with your order.

ONE PART DRIVESHAFT MEASUREMENTS

■ MEASURE FOR U-JOINT AT THIRD MEMBER YOKE

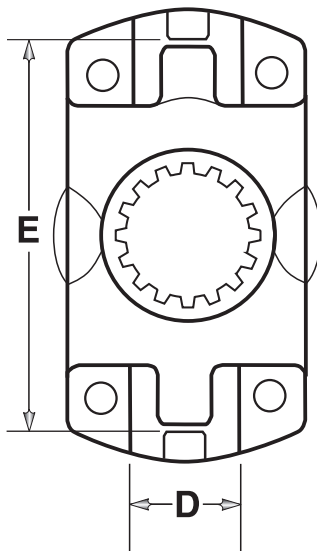

- E = 3-7/32" D = 1-1/16"
- E = 3-7/32" D = 1-1/8"
- E = 3-5/8" D = 1-1/16"
- E = 3-5/8" D = 1-1/8"
- E = 3-5/8" D = 1-3/16"
- E = 4-3/16" D = 1-3/16"
- E = 4-3/16" D = 1-3/8"
- E = 4-31/32" D = 1-3/8"

**THESE DIMENSIONS
MUST BE ACCURATE.
IF YOU DON'T GET
THEM, CHECK FOR
WEAR AT "E" OR "A".**

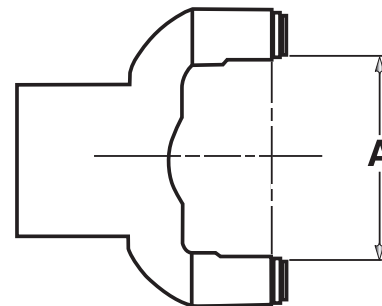

- SOME CHRYSLER CORP.**
- A = 2-1/8"
 - A = 2-5/8"
- SOME GENERAL MOTORS**
- A = 2-9/16"

- "X" MEASUREMENT IS FROM THE TIP OF THE TRANSMISSION OUTPUT SHAFT TO THE CENTERLINE OF U-JOINT AT THE THIRD MEMBER. THIS WILL BE THE FLAT SURFACE WHERE THE U-BOLT HOLE IS DRILLED.
- "Y" MEASUREMENT IS THE LENGTH OF THE OUTPUT SHAFT PROTRUSION.

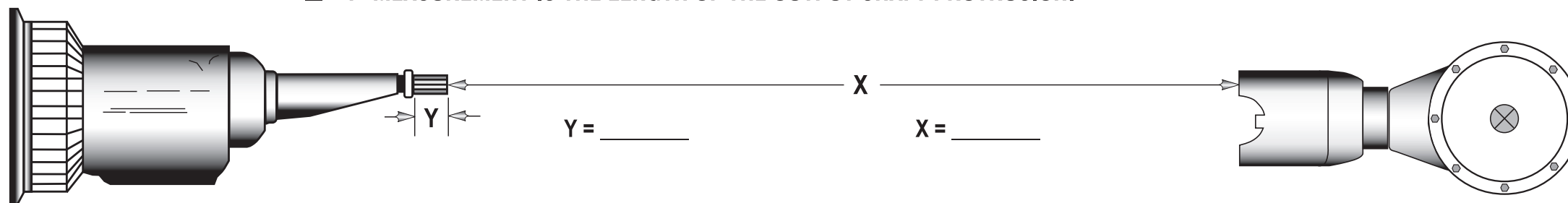

TRANSMISSION MAKE & MODEL: _____ DIFFERENTIAL MAKE & MODEL: _____

NOTE: TH400 TRANS OUTPUT SHAFT DRILLED & TAPPED UNDRILLED

HANDY TIPS!

- THE VEHICLE MUST BE MEASURED AS IT IS TO OPERATE. JACKING UP THE VEHICLE WILL CHANGE YOUR DIMENSIONS.
- IF YOUR VEHICLE HAS A BOLT-ON TRANSMISSION YOKE, MEASURE BETWEEN U-JOINT CENTERLINES
- IF THERE IS A FLANGE MOUNT ON EITHER OR BOTH ENDS, MEASURE TO ITS FACE.
- WHEN YOU INSTALL U-BOLTS DO NOT OVER TIGHTEN THEM. "D" DIMENSION 1-1/16" AND 1-1/8" : 14-17 FT. LB.; 1-3/16" : 20-24 FT. LB.; 1-3/8" : 32-37 FT. LB.

To fill out figure 10, first measure for the pinion u-joint. If the pinion yoke has square tabs to center the u-joint measure between them for "E". Then measure the cap seat for "D". These measurements must be accurate because cap diameter varies by sixteenths of an inch. If there is no such tab, refer to the "Some Chrysler" or "Some GM" as appropriate. Check the box matching your results.

Next measure from the flat surface of the pinion yoke, where the fasteners attach the u-joint, to the flat end of the transmission output shaft. Note this as "X". Note the amount of splined shaft protruding past the transmission seal as "Y". Finally note the make and model of your transmission. With this information a drive shaft can be built to fit your car properly.

If you call Inland Empire Drive Line with this information be prepared for some additional discussion. We will want to know how much horse power your engine produces, whether it is a big or small block and whether it has a blower and/or a nitrous oxide system. We will ask about the intended use of your car, its tires, weight, and the maximum engine RPM. All these questions are intended to guide us in u-joint size and tube diameter selection.

Our recommendation to you will be based on both drive shaft capacity and safety.

HOW TO MEASURE FOR DRIVE SHAFTS - TWO PIECE

Some cars will require a two-piece drive shaft system because of overall length or because of obstacles that must be avoided. Long wheel base cars, lowered cars, hydraulic and "X" frame cars all fall into this category. While the 1958 to 1964 Chevrolet cars are the most common example, long classics that had torque tubes, long bed pick up trucks and cab-over car haulers are some others.

Two-piece shaft systems are the means used to reduce Critical Speed where long spans exist. As described above, the Critical Speed of any shaft is a theoretical number reduced by both the physics at work in the shaft and by the uncertainties of the installation. While guidelines are published showing recommended maximum shaft lengths at various RPM, judgment is required when these lengths are approached. While each vehicle is different and no hard and fast length rule applies to all cases, start asking questions when your X measurement is 51 inches or more.

TWO PART DRIVESHAFT MEASUREMENTS

MEASURE FOR U-JOINT AT THIRD MEMBER YOKE

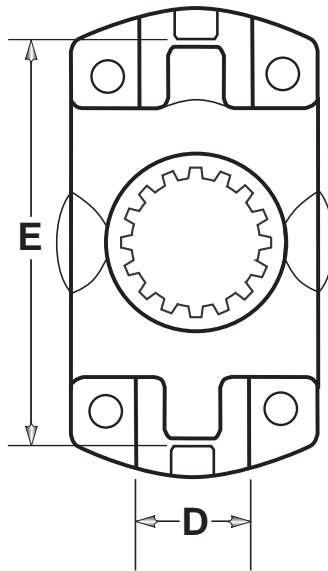

- E = 3-7/32" D = 1-1/16"
- E = 3-7/32" D = 1-1/8"
- E = 3-5/8" D = 1-1/16"
- E = 3-5/8" D = 1-1/8"
- E = 3-5/8" D = 1-3/16"
- E = 4-3/16" D = 1-3/16"
- E = 4-3/16" D = 1-3/8"
- E = 4-31/32" D = 1-3/8"

**THESE DIMENSIONS
MUST BE ACCURATE.
IF YOU DON'T GET
THEM, CHECK FOR
WEAR AT "E" OR "A".**

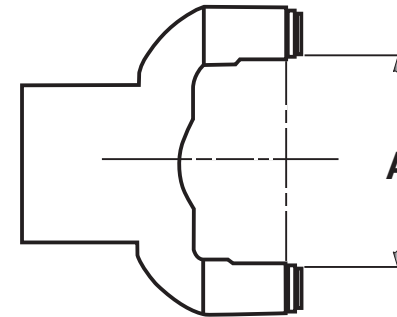

- SOME CHRYSLER CORP.**
- A = 2-1/8"
 - A = 2-5/8"
- SOME GENERAL MOTORS**
- A = 2-9/16"

- "W" MEASUREMENT IS FROM THE TIP OF THE TRANSMISSION OUTPUT SHAFT TO A CENTER BEARING BOLT HOLE OR SLOT.
- "X" MEASUREMENT IS FROM THE BOLT HOLE OR SLOT TO THE CENTERLINE OF U-JOIN A THE THIRD MEMBER. THIS WILL BE THE FLAT SURFACE WHERE THE U-BOLT HOLE IS DRILLED.
- "Y" MEASUREMENT IS THE LENGTH OF THE OUTPUT SHAFT PROTRUSION.

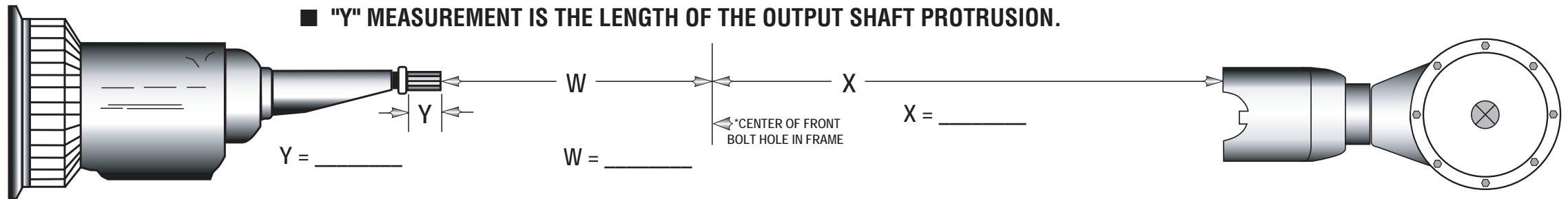

TRANSMISSION MAKE & MODEL: _____ DIFFERENTIAL MAKE & MODEL: _____

NOTE: TH400 TRANS OUTPUT SHAFT DRILLED & TAPPED UNDRILLED

HANDY TIPS!

- THE VEHICLE MUST BE MEASURED AS IT IS TO OPERATE. JACKING UP THE VEHICLE WILL CHANGE YOUR DIMENSIONS.
- IF YOUR VEHICLE HAS A BOLT-ON TRANSMISSION YOKE, MEASURE BETWEEN U-JOINT CENTERLINES
- IF THERE IS A FLANGE MOUNT ON EITHER OR BOTH ENDS, MEASURE TO ITS FACE.
- WHEN YOU INSTALL U-BOLTS DO NOT OVER TIGHTEN THEM. "D" DIMENSION 1-1/16" AND 1-1/8" : 14-17 FT. LB.; 1-3/16" : 20-24 FT. LB.; 1-3/8" : 32-37 FT. LB.

Figure 11 shows the measurements needed. The pinion joint is measured as above. In the case of the two-piece shaft, "W" is measured from the flat end of the transmission output shaft to the center of the slot for mounting the center support. "X" is measured from this slot center to the pinion yoke u-joint attaching hardware face. * '55 to '64 Chevrolet Only.

Angle set up for two-piece shafts is similar to the one piece. All 3 working angles should add up to zero. The easiest way to do this is mounting the front shaft section so it has zero degrees through the joint at the transmission. The rear shaft may then be treated as if it were a single shaft. Sometimes this is not possible and all three angles must be juggled to arrive at zero. It is a good idea to allow for some up and down adjustment at the center support mount so the angles may be tuned as necessary once the car is driven.

There is no hard and fast law governing shaft lengths. It is customary though, to divide the overall length 40% front and 60% rear. Our experience with motorhome manufacturers has taught us not to make either shaft, especially the front shaft, shorter than 18 inches. Available cross members, frame obstacles and u-joint angle cancellation will all play their part in dividing up the span.

All of the questions about power and intended use apply to the two-piece set. Like the one piece they can be upgraded in capacity. Unlike the one piece their tube diameter can actually be reduced because of the shorter shaft sections. This size reduction can eliminate a lot of floor pan, tunnel and seat bottom modification and may make a two-piece more economical to use where it isn't really required.

When planning your conversion, take the time to consult with as many experts as you can. A few minutes or hours of preparation can save you endless hours of rebuilding during the construction of your project as well as save you the agonies of misjudgment. There are many resources available through the internet as well as the reliable vendors who are working to sell you the products you need to do the job correctly, ask for their advice and use their knowledge.

— Greg

INLAND EMPIRE
DRIVELINE®

Check out an excellent selection of performance driveline & axles on our website.