

Installation Instructions

Before using the Mounting hooks, carefully read the installation instructions as well as the installation instructions for basic carrier systems, and follow all usage instructions. After reading the installation instructions, keep it in a safe place along with the installation instructions for basic carrier systems. If you are to give the mounting hooks to a third person, provide the installation instructions to ensure safe installation and usage.

For INNO dedicated ski & snowboard carriers, read the carrier installation instructions to determine proper mounting locations.

The SU Mounting hooks include the parts listed below. Verify that all of these parts are included in the carrier system you have purchased.

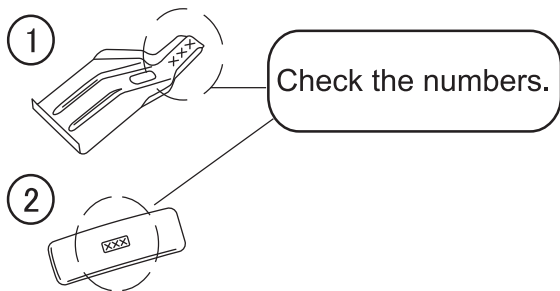

No.	Part	# of Part	Qty
1	Hook	115	2
		112	2
2	Base	425	2
		429	2

NOTE

The specifications or external appearance of this product or any of the genuine spare parts may be changed for improvement without prior notification.

Manufacturer	Model	Type	Year	Maximum loading capacity	Bikes
TOYOTA	4 RUNNER		2003 - 2009	140 lbs (64 kg) (Load + Base rack + Attachments)	3

Maximum loading capacity is 140 lbs(64 kg) for this vehicle type.

Stay interior dimensions
 Front 43 1/4 inch(1100 mm)
 Rear 42 1/2 inch(1078 mm)

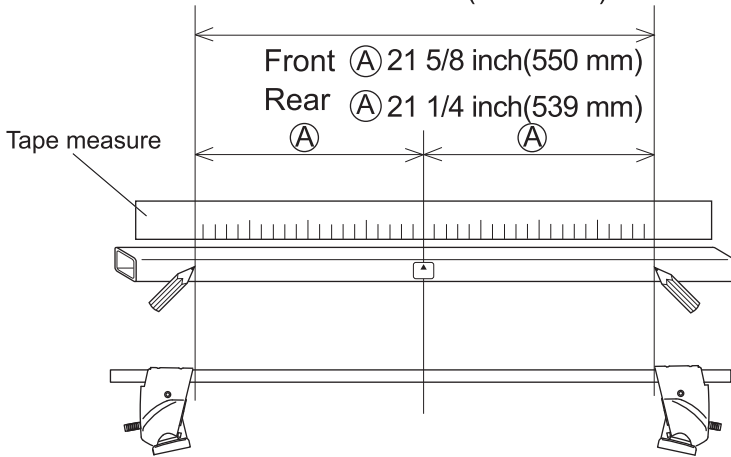

Loosely attach hooks

	Hook number
Front hook	115
Rear hook	112

■ Hook / base installation position

Front

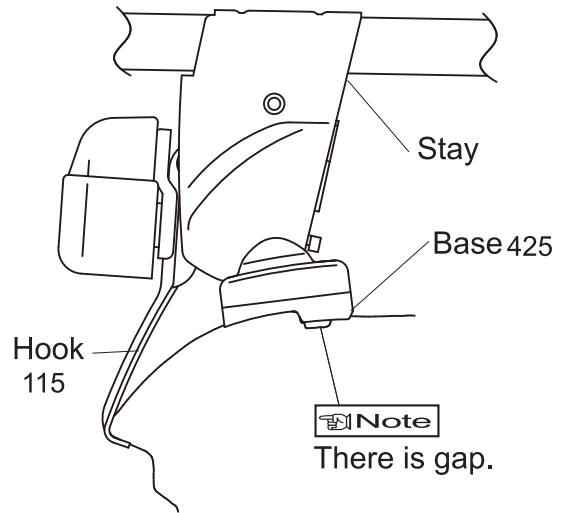

Rear

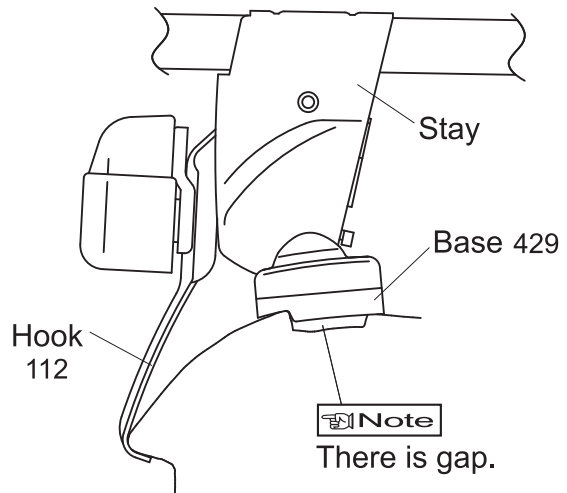

Note

● When knob is tightened, base moves slightly outward to the position illustrated above.

Install Bases

	Base number
Front base	425
Rear base	429

Mounting positions

- Position the stays so that bolts align at specified mounting points.

