



2018+ JEEP WRANGLER JL / GLADIATOR JT

JEEP JL/JT OVERHEAD BRACKET (WITH A-PILLAR MOUNTS)

The KC Jeep Wrangler JL / Gladiator JT Overhead Bracket Set (SKU #7327) is made of black, textured powder coated steel and includes integrated A-Pillar mounts. These are designed to easily mount KC Gravity® LED Pro6 and C-Series light bars to factory bolt locations.

WARNING: Please read all instructions before beginning installation. These guidelines are provided in good faith to help prevent any issues arising from errors during installation. The manufacturer of this product shall not be held responsible for any user actions taken or not taken during installation. There are many details of the installation that are assumed to be general mechanical knowledge to experienced installers; which are not detailed in these instructions. These installation guidelines are intended to serve as professional recommendations and are not a step-by-step, fail-safe installation checklist. Selection of an experienced installer is the sole responsibility of the project owner.



Jeep Wrangler JL Rubicon with Overhead Mounts

Parts Included:

- QTY 2 - Overhead brackets
- QTY 2 - Protective gaskets
- QTY 4 - M8 lower cowl bolts and washers
- QTY 2 - A-Pillar light mounts (optional)
- QTY 4 - Short M6 bolts with nuts and washers (optional)

TOOLS NEEDED FOR INSTALLATION

T40 & T45 TORX BIT

4MM & 5MM HEX KEY



INSTRUCTIONS FOR INSTALLATION

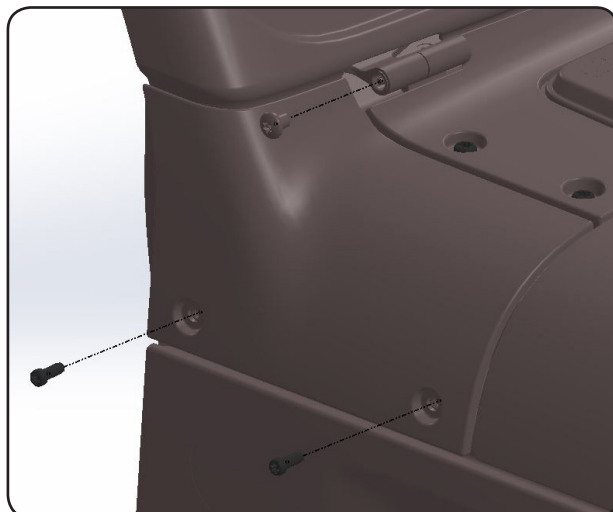

1. REMOVE STOCK HARDWARE

- Remove the two T40 Torx head lower bolts in the cowl panel using slow and even pressure to remove the bolts to avoid damaging the hardware.
- Remove the windshield hinge nut using the T45 Torx bit, being careful not to chip the paint on the windshield hinge nut.
- Repeat for both sides.

JEEP WRANGLER JL/JT OVERHEAD LIGHT BAR

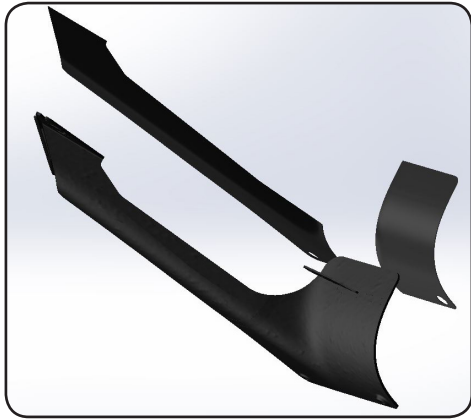

2. INSTALL THE SILICONE GASKETS

- Confirm proper orientation of gaskets on the brackets and then remove a portion of the paper backing on the protective gaskets.
- Stick the exposed portion of the adhesive backing onto the bracket while lining up the gasket. There should be about a 1/16" gap between the edge of the bracket and the edge of the gasket.
- Repeat for all 4 gaskets. Apply pressure for complete adhesion.

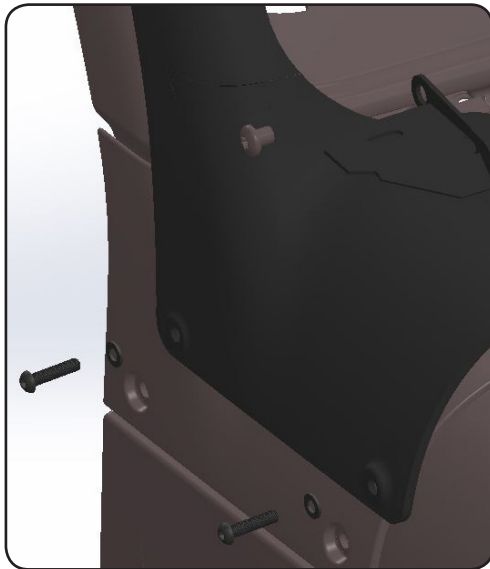

3. INSTALL OVERHEAD BRACKET

- Set the bracket in place on the vehicle and hand tighten all hardware:
- Install the supplied M8 bolts through the washers and bracket into the factory lower cowl bolt holes.
- Apply blue thread lock on the windshield hinge nut and then place it through the bracket and install.
- Tighten all bolts.
- Repeat for both sides.

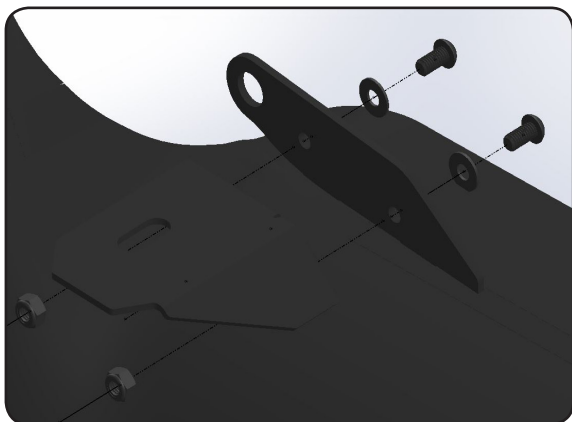

4. INSTALL A-PILLAR MOUNT (optional)

- Place the supplied M6 washer on the M6 screw and align the two holes on the overhead bracket with the two on the a-pillar bracket tab.
- Place the M6 screws through the holes and thread on the nuts by hand.
- Tighten the nuts with a 10mm deep socket and 4mm allen key.