



# TYPHOON INTAKE SYSTEMS

NOT LEGAL FOR SALE OR USE ON ANY POLLUTION CONTROLLED MOTOR VEHICLE IN CALIFORNIA OR STATES ADOPTING CALIFORNIA EMISSION PROCEDURES.

## INSTALLATION INSTRUCTIONS

**69-6034TS**  
**MAZDA**  
**2018-19 6 / CX-9**  
**L4-2.5L**

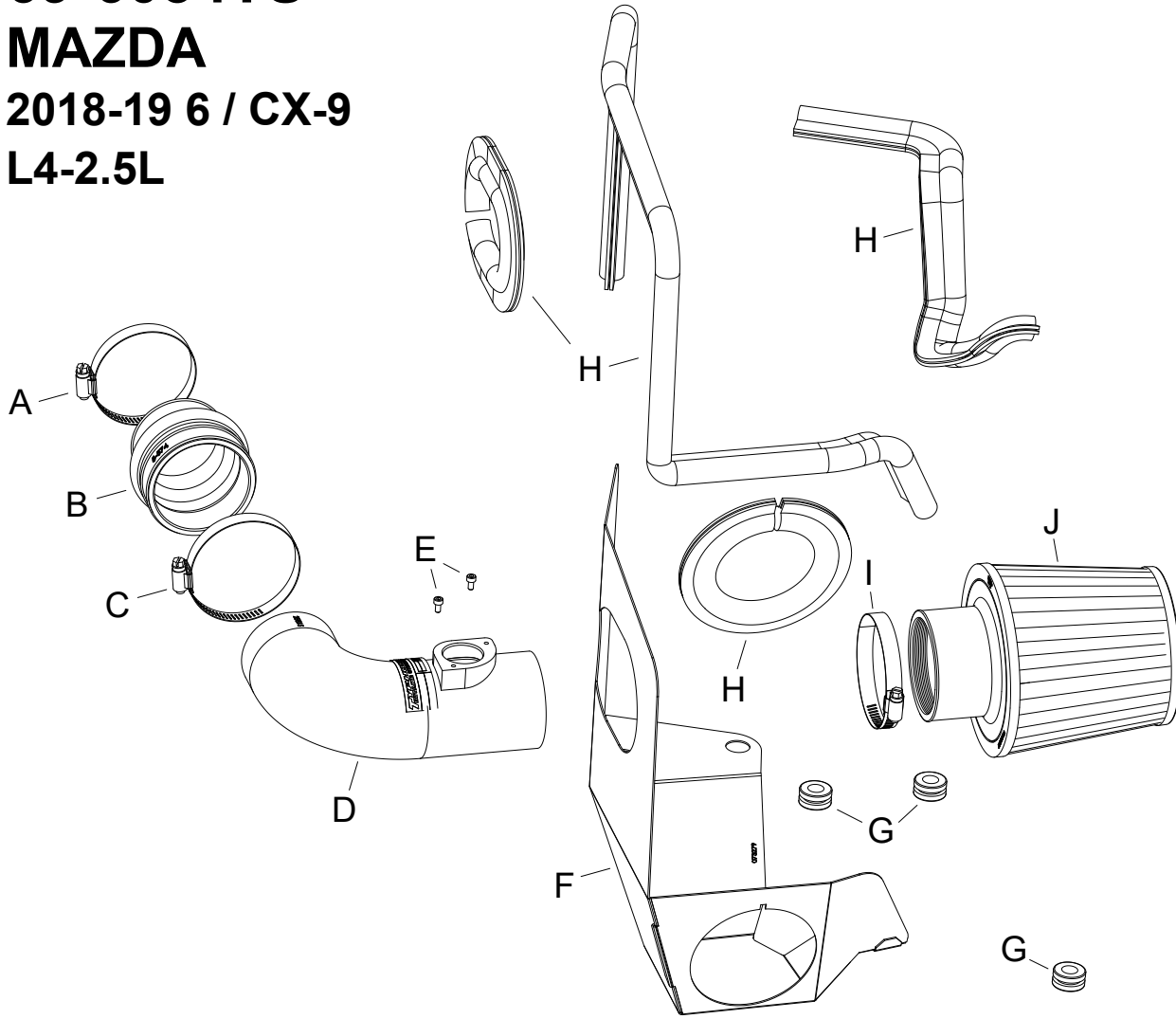

### TOOLS NEEDED:

- 3mm allen
- 4mm allen
- flat blade screw driver
- Philips screw driver
- 10mm wrench
- ratchet
- 10mm socket, pliers

### PARTS LIST:

Description	Qty.	Part #
A HOSE CLAMP; #44	1	08577
B HOSE; HUMP 2.5"/3" X 3"	1	5-574
C HOSE CLAMP; #48	1	08601
D TUBE; 3"OD X 10"L, AL, SILVER	1	25815S
E BOLT; M4-.7 X 8MM, ALLEN, SS	2	07733
F HEAT SHIELD; 69-6034, MILD	1	073279
G GROMMET; 1"OD, 1/2"ID, 1/2"	3	08064
H EDGE TRIM; 3/4" BULB, TOP	1	102503
I HOSE CLAMP; #52	1	08610
J 3"FLG, 6"B, 5"T, 5-9/16"H	1	RU-4990

**NOTE: FAILURE TO FOLLOW INSTALLATION INSTRUCTIONS AND NOT USING THE PROVIDED HARDWARE MAY DAMAGE THE INTAKE TUBE, THROTTLE BODY AND ENGINE.**

### TO START:

1. Turn off the ignition and disconnect the negative battery cable.  
**NOTE: Disconnecting the negative battery cable erases pre-programmed electronic memories. Write down all memory settings before disconnecting the negative battery cable. Some radios will require an anti-theft code to be entered after the battery is reconnected. The anti-theft code is typically supplied with your owner's manual. In the event your vehicles anti-theft code cannot be recovered, contact an authorized dealership to obtain your vehicles anti-theft code.**



2. Disconnect the mass air sensor electrical connection.



3. Loosen the clamps that secure the factory intake hose and then remove the factory hose from the vehicle.



4. Remove the two bolts that secure the fresh air intake scoop to the core support.



5. Pull straight up on the air filter housing assembly and remove it from the vehicle.  
**NOTE: K&N Engineering, Inc., recommends that customers do not discard factory air intake.**



6. Lift the locking tab and then rotate the fresh air scoop counter clockwise to remove it from the air filter housing.

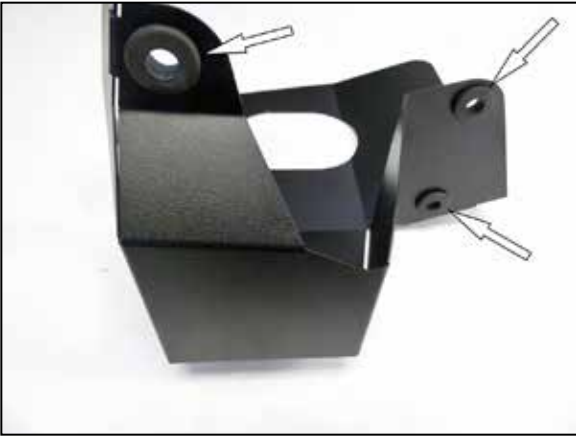

7. Install the three provided grommets into the heat shield as shown.

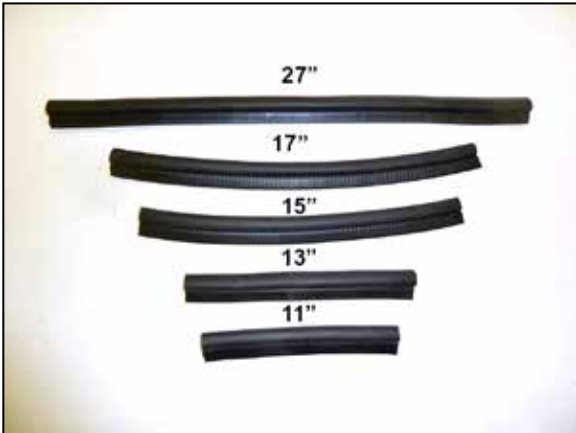

8. Cut the provided edge trim into the five lengths as shown.



9. Install the cut edge trim onto the heat shield as shown.



10. Install the factory fresh air intake scoop into the K&N® heat shield as shown.



11. Remove the mass air sensor from the factory air filter housing and install it into the K&N® intake tube and secure with the provided hardware.



12. Install the air filter onto the K&N® intake tube and secure with the provided hose clamp.  
**NOTE: Drycharger® air filter wrap; part # RX-4990DK is available to purchase separately. To learn more about Drycharger® filter wraps.**



13. Install the hump coupler (5-574) onto the turbo inlet pipe and secure with the provided hose clamp.



14. Install the heat shield assembly into the vehicle so the mounting grommets secure over the factory mounting studs. Secure the fresh air scoop with the factory bolts.



15. Install the K&N® intake tube through the heat shield, adjust for best fit and secure with the provided hose clamp.



16. Reconnect the mass air sensor electrical connection.



17. Reconnect the vehicle's negative battery cable. Double check to make sure everything is tight and properly positioned before starting the vehicle.

18. It will be necessary for all K&N® high flow intake systems to be checked periodically for realignment, clearance and tightening of all connections. Failure to follow the above instructions or proper maintenance may void warranty.

#### ROAD TESTING:

1. Start the engine with the transmission in neutral or park, and the parking brake engaged. Listen for air leaks or odd noises. For air leaks secure hoses and connections. For odd noises, find cause and repair before proceeding. This kit will function identically to the factory system except for being louder and much more responsive.

2. Test drive the vehicle. Listen for odd noises or rattles and fix as necessary.

3. If road test is fine, you can now enjoy the added power and performance from your kit.

4. K&N Engineering, Inc., requires cleaning the intake system's air filter element every 100,000 miles. When used in dusty or off-road environments, our filters will require cleaning more often. We recommend that you visually inspect your filter once every 25,000 miles to determine if the screen is still visible. When the screen is no longer visible some place on the filter element, it is time to clean it. To clean and re-oil, purchase our filter Recharger® service kit, part number 99-5050 or 99-5000 and follow the easy instructions.

**NOT LEGAL FOR SALE OR USE ON ANY POLLUTION CONTROLLED MOTOR VEHICLE IN CALIFORNIA OR STATES ADOPTING CALIFORNIA EMISSION PROCEDURES.**