



TYPHOON INTAKE SYSTEMS

NOT LEGAL FOR SALE OR USE ON ANY POLLUTION CONTROLLED MOTOR VEHICLE IN CALIFORNIA OR STATES ADOPTING CALIFORNIA EMISSION PROCEDURES.

INSTALLATION INSTRUCTIONS

69-8623TS
TOYOTA
2019 RAV4
L4-2.5L

TOOLS NEEDED:

- flat blade screw driver
- phillips screw driver
- 3mm allen key
- ratchet, extension
- 10mm socket
- 9/16" wrench
- 3/4" wrench
- pliers

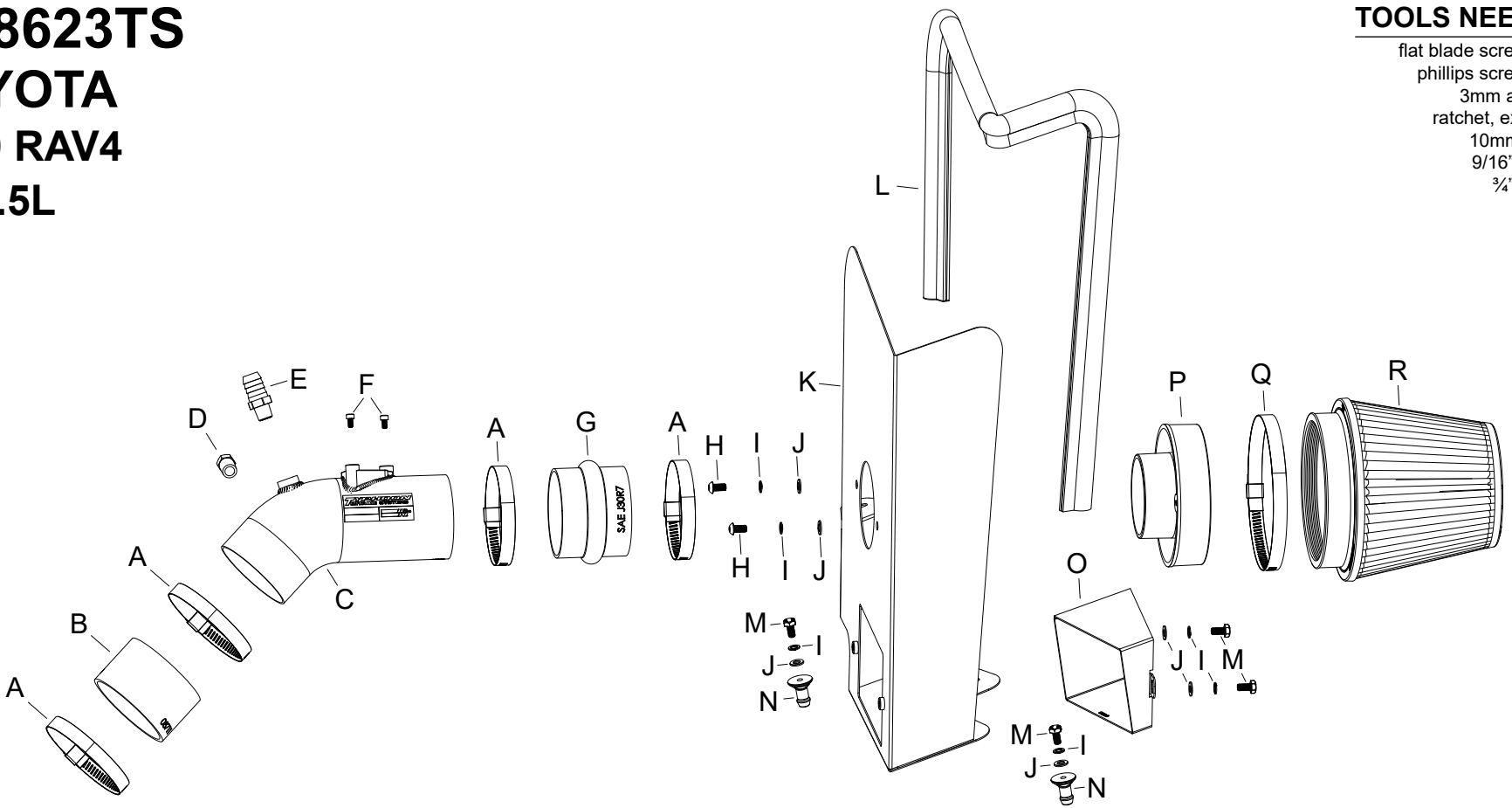

PARTS LIST:

Description	Qty.	Part #	Description	Qty.	Part #	Description	Qty.	Part #
A HOSE CLAMP; #48	4	08601	G HOSE; HUMP 3"ID X 2.5"L	1	087121	M BOLT; M6 X 1 X 12MM, HEX, SS	4	07727
B HOSE; 3"ID X 2"L REINFORCED	1	08711	H BOLT; M6 X 1", 12MM, SS	2	07794	N MOUNT, PLASTIC AIRBOX	2	8-186-1
C TUBE; 3"OD X 7"L, AL, SILVER	1	25834S	I WASHER; M6 SPLIT LOCK ZINC	6	1-3025	O AIR DUCT; 69-8621, MILD STL	1	073260
D FITTING; BARBED, 1/8, 1/4"NPT	1	08052	J WASHER; 6MM FLAT, SS	6	08269	P ADAPTER; FILTER, 3.0"OD	1	21569
E VENT; STRT, 5/8 BARBED 1/4	1	08911-1	K HEAT SHIELD; 69-8623, MILD	1	07372	Q CLAMP; #88, 1/2", SS	1	KITHS88
F BOLT; M4-.7 X 8MM, ALLEN, SS	2	07733	L EDGE TRIM; 3/4" BULB, TOP	1	102496A	R 5"FLG, 6-1/2"B, 4-1/2"T, 5-1/2"H	1	RU-5147

NOTE: FAILURE TO FOLLOW INSTALLATION INSTRUCTIONS AND NOT USING THE PROVIDED HARDWARE MAY DAMAGE THE INTAKE TUBE, THROTTLE BODY AND ENGINE.

TO START:

1. Turn off the ignition and disconnect the negative battery cable.
NOTE: Disconnecting the negative battery cable erases pre-programmed electronic memories. Write down all memory settings before disconnecting the negative battery cable. Some radios will require an anti-theft code to be entered after the battery is reconnected. The anti-theft code is typically supplied with your owner's manual. In the event your vehicles anti-theft code cannot be recovered, contact an authorized dealership to obtain your vehicles anti-theft code.



2. Remove the two bolts that secure the fresh air intake duct and then remove the duct from the vehicle.



3. Disconnect the mass air sensor electrical connection.



4. Disconnect the Crank case vent line and small vent line shown.



5. Release the spring clamp for the intake hose at the throttle body and then disconnect intake hose from the throttle body.



6. Pull upwards on the air box assembly and remove it from the vehicle.
NOTE: K&N Engineering, Inc., recommends that customers do not discard factory air intake.



7. Install the provided vent fittings into the K&N® intake tube as shown.

NOTE: Plastic NPT fittings are easy to cross thread. Install the vent fitting “hand” tight, then turn it two complete turns with a wrench.



8. Remove the mass air sensor from the factory housing and install it into the K&N® intake tube and secure with the provided hardware.



9. Install the edge trim onto the heat shield as shown. Some trimming of the edge trim will be necessary.



10. Install the filter adapter into the heat shield and secure with the provided hardware.

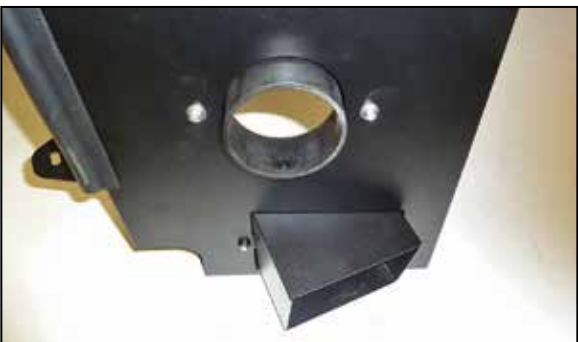

11. Install the K&N® fresh air duct into the heat shield and secure with the provided hardware.



12. Install the two mounting posts onto the heat shield as shown using the provided hardware.



13. Install the heat shield into the vehicle so the mounting posts insert into the factory grommets.



14. Install the provided hump coupler (087121) onto the filter adapter and secure with the provided hose clamp.



15. Install the provided straight coupler (08711) onto the throttle body and secure with the provided hose clamp.



16. Install the K&N® air filter onto the filter adapter and secure with the provided hose clamp.
NOTE: Drycharger® air filter wrap; part # RU-5147DK is available to purchase separately.



17. Install the K&N® intake tube assembly into the couplers and adjust for best fit and secure with the provided hose clamps.



18. Connect the crank case vent line and vacuum line to the vent fittings installed into the K&N® intake tube.

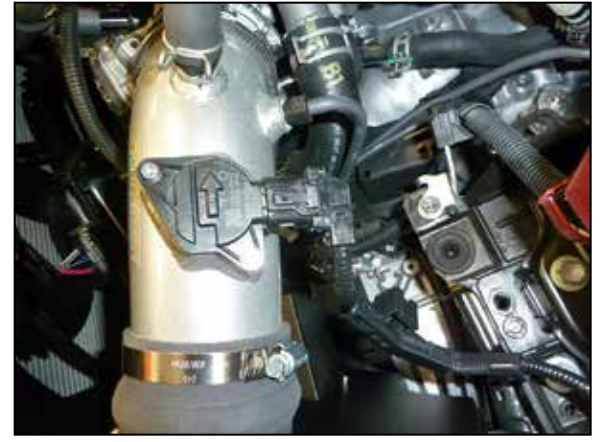

19. Reconnect the mass air sensor electrical connection.



20. Reinstall the fresh air intake duct and secure with the factory hardware.



21. Reconnect the vehicle's negative battery cable. Double check to make sure everything is tight and properly positioned before starting the vehicle.

22. It will be necessary for all K&N® high flow intake systems to be checked periodically for realignment, clearance and tightening of all connections. Failure to follow the above instructions or proper maintenance may void warranty.

ROAD TESTING:

1. Start the engine with the transmission in neutral or park, and the parking brake engaged. Listen for air leaks or odd noises. For air leaks secure hoses and connections. For odd noises, find cause and repair before proceeding. This kit will function identically to the factory system except for being louder and much more responsive.

2. Test drive the vehicle. Listen for odd noises or rattles and fix as necessary.

3. If road test is fine, you can now enjoy the added power and performance from your kit.

4. K&N Engineering, Inc., requires cleaning the intake system's air filter element every 100,000 miles. When used in dusty or off-road environments, our filters will require cleaning more often. We recommend that you visually inspect your filter once every 25,000 miles to determine if the screen is still visible. When the screen is no longer visible some place on the filter element, it is time to clean it. To clean and re-oil, purchase our filter Recharger® service kit, part number 99-5050 or 99-5000 and follow the easy instructions.

NOT LEGAL FOR SALE OR USE ON ANY POLLUTION CONTROLLED MOTOR VEHICLE IN CALIFORNIA OR STATES ADOPTING CALIFORNIA EMISSION PROCEDURES.