

LOCTITE[®]

“Do It Right” User’s Guide

The “When, Where & How” to Use
Loctite[®] Automotive Maintenance Products



Excellence is our Passion

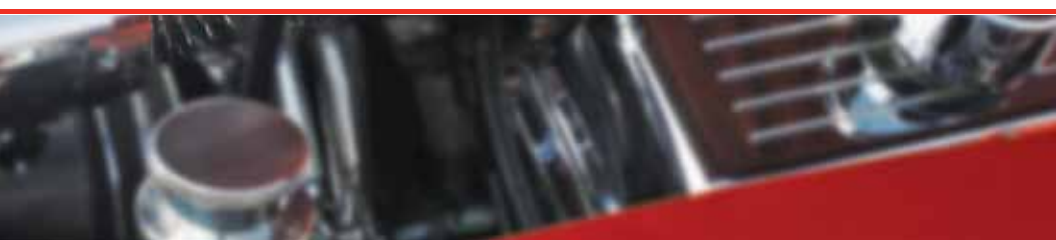

INTRODUCTION

INTRODUCTION TO ANAEROBIC ADHESIVES AND SEALANTS

Anaerobic adhesives and sealants were developed by the founder of the Loctite Corporation, now the Henkel Corporation, in 1953 and, since then, they have significantly evolved to meet the highest requirements of vehicle manufacturers and vehicle maintenance and repair.

Anaerobic adhesives and sealants are resins that convert from liquid to a tough structural solid in the absence of air and the presence of metal. The primary functions of anaerobic resins are:

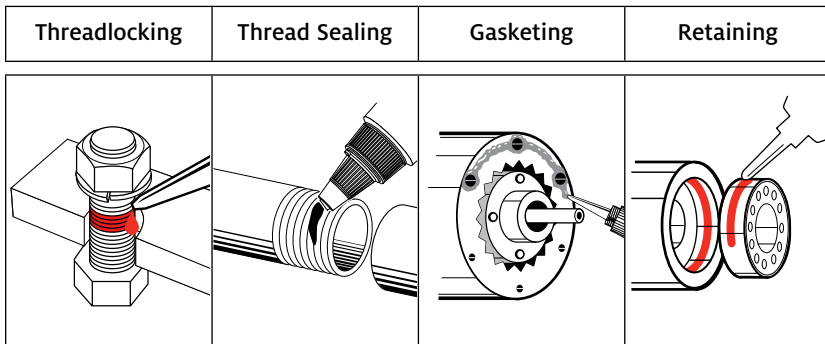

Each one of these functions is based upon control of five major variables: strength, viscosity, adhesion, flexibility and temperature resistance. These five parameters give anaerobic users considerable latitude in adjusting properties for optimum performance in specific application areas.

Another variable that should be considered is the surface on which the adhesive will be applied. For certain surfaces or other special requirements, the use of a primer is recommended.

WHY USE A PRIMER?

1. Primers activate inactive surfaces.
2. Primers speed cure times for faster return to service.
3. Primers speed curing through larger gaps and deep threads.
4. Primers substantially speed cure times on cold parts.
5. Primers act as cleaning agents.

Active surfaces (Primer optional): Brass, copper, bronze, iron, soft steel, nickel.

Inactive surfaces (Primer required): Aluminum, stainless steel, magnesium, zinc, black oxide, cadmium, titanium, others.

THREADLOCKING

THRU HOLES (BOLTS AND NUTS)

LIQUID, SEMI-SOLIDS AND DRY-TO-TOUCH TAPE

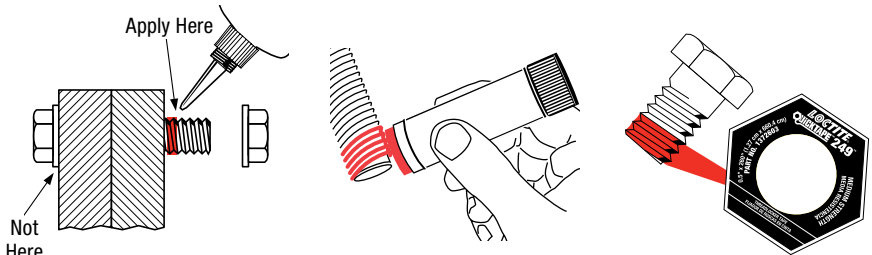

1. Clean all threads (bolt and nut) with a cleaner.
2. If necessary, spray all threads with Loctite® Klean 'N Prime™. Allow to dry.
3. Select the proper strength Loctite® threadlocker.
4. Insert bolt into thru hole assembly.
5. Apply several drops of liquid threadlocker onto bolt at targeted, tightened nut engagement area or, when using the stick product, completely fill the root of the threads at the area of engagement.
6. Assemble and tighten nut as usual.

BLIND HOLES (CAP SCREWS, ETC.)

LIQUID ONLY

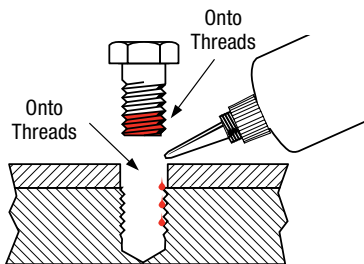

1. Clean all threads (bolt and hole) with a cleaner.
2. If necessary, spray (bolt and hole) with Loctite® Klean 'N Prime™. Allow 30 to 70 seconds to dry.
3. Select the proper strength Loctite® threadlocker.
4. Squirt several drops down the sides of the female threads.
5. Apply several drops to bolt.
6. Tighten as usual.

Note: Using Loctite® threadlockers will virtually eliminate stripped threads, in aluminum or magnesium housings, caused by galvanic corrosion.

THREADLOCKING

BLIND HOLES (STUDS, ETC.)

LIQUID ONLY

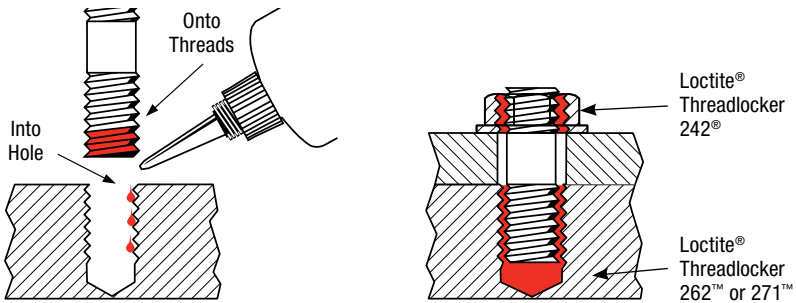

1. Clean all threads (bolt and hole) with a cleaner.
2. If necessary, spray all threads with Loctite® Klean 'N Prime™'. Allow to dry.
3. Squirt several drops of Loctite® Threadlocker **262™** or **271™** down the sides of the female threads.

Note: Use Loctite® Threadlocker **277™** if stud is over 1" diameter.

4. Apply several drops of Loctite® Threadlocker **262™** or **271™** onto stud threads.
5. Install studs.
6. Position cover, head, etc.
7. Apply drops of Loctite® Threadlocker **242®** onto exposed threads.
8. Tighten nuts as required.*

* 243™ may be used in place of 242®. Its primerless formula eliminates the need for Loctite® Klean 'N Prime™'.

ADJUSTMENT SCREWS

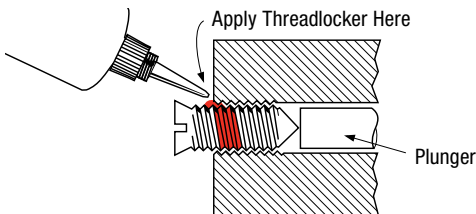

1. Adjust screw to proper setting.
2. Apply several drops of Loctite® Threadlocker **290™** at screw and body juncture.
3. Avoid touching bottle tip to metal.

Note: • If re-adjustment is difficult, apply heat to screw with soldering gun (500°F).

THREADLOCKING

PRE-ASSEMBLED FASTENERS

LIQUID ONLY

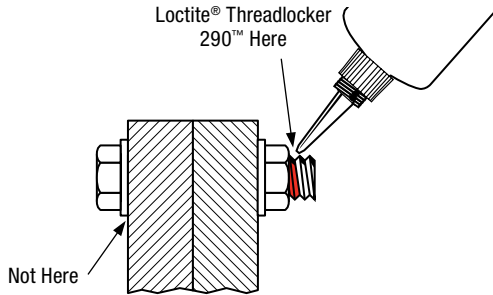

1. Clean bolts and nuts with a cleaner.
2. Assemble components.
3. Tighten nuts.
4. Apply several drops of Loctite® Threadlocker **290™** at the nut and bolt juncture.
5. Avoid touching bottle tip to metal.

Note: For preventive maintenance on existing equipment:
RETIGHTEN nuts and apply Loctite® Threadlocker **290™**
at the nut and bolt juncture.

LOCTITE® BRAND THREADLOCKER QUICK SELECTOR

USE	STRENGTH	PRODUCT	COLOR
Small Screws	Low	222™	Purple
Nuts & Bolts	Medium	242® / 243™ / Blue Threadlocker Stick	Blue
Pre-Assembled*	Medium	290™	Green
Overhead	Medium	249™ Tape or Stick	Blue
Pre-Applied up to 30 Days	Medium	249™ Tape	Blue
Nuts & Bolts	High	262™ / Red Threadlocker Stick	Red
Studs (up to 1½")	High	271™	Red
Studs (up to 1")	High	272™	Red
Studs (over 1")	High	277™	Red

* Wicking Grade

THREAD REPAIR

STRIPPED THREAD REPAIR

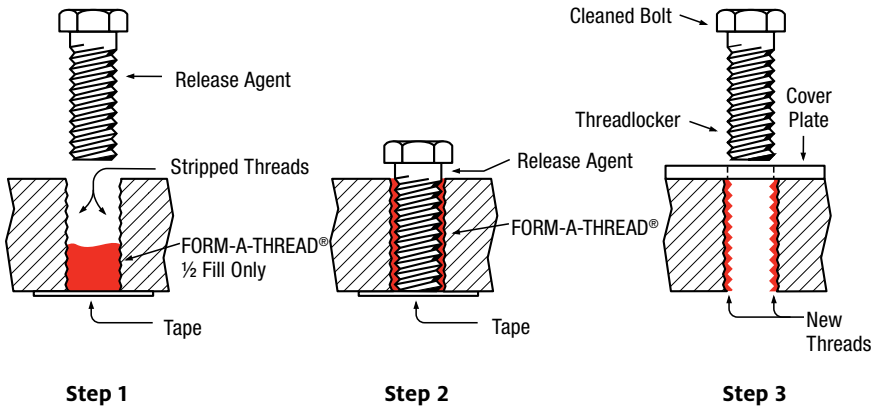

STANDARD THREAD REPAIR

1. Follow instructions on Loctite® FORM-A-THREAD® package.
2. If cover plate is used for bolt alignment:
 - (a) Apply release agent to mating faces around repair area.
 - (b) Use “waxed” paper or similar film between faces.
3. A “jiggling/twisting” motion, when initially inserting bolt improves the thread conformation.

Note: NOT intended for engine stud repair.

SMALL HOLE/FINE THREAD REPAIR

- OPTION 1.** Drill out damaged hole to oversize, then follow STANDARD THREAD REPAIR.
- OPTION 2.** Apply Loctite® FORM-A-THREAD® to screw and insert into damaged hole. Clamp in place, while product cures.

STUD INSTALLATION — PERMANENT (LIGHT DUTY)

1. Use stud or cut “all threads” to desired length.
2. Do NOT apply release agent to stud.
3. Proceed as with standard thread repair.
4. Allow 30 minutes to cure.
5. Assemble as required.

THREAD SEALING

STANDARD FITTINGS – PIPES, HYDRAULIC OR AIR

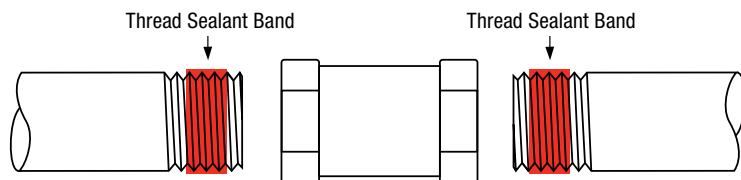

1. Clean parts of contamination. If necessary, spray Loctite® Klean 'N Prime™ onto threaded parts (male and female). Allow to dry.
Note: Primer is not required for brass parts.
2. Apply a band of Loctite® Thread Sealant **592™** or **565™** to male threads starting one to two threads from end of pipe.
3. Assemble parts snugly. Do not overtighten.
4. If initial pressure exceeds 1000 psi*, wait 30 minutes before pressurizing.

Note: • For stainless steel components, use Loctite® Thread Sealant **565™**.

- For general purpose thread sealing, use Loctite® Thread Sealant **565™** or Loctite® Pipe Sealant Stick.
- For fine filtration systems requiring zero contamination, use Loctite® Thread Sealant **545™** for hydraulic/pneumatic fittings.
- Do not use on oxygen or strong oxidizers (chlorine).
- For applications requiring temperature range above 300°F (no higher than 400°F), use Loctite® Thread Sealant **592®**.

* Depending on conditions

PIPE UNIONS

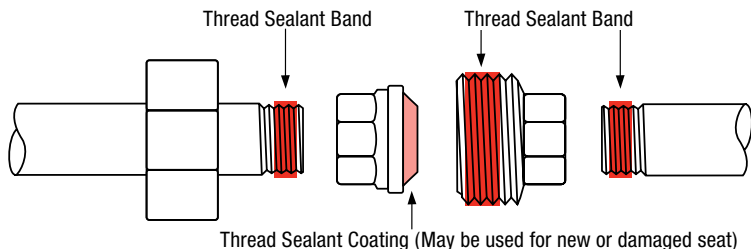

1. Disassemble and, if necessary, spray all components with Loctite® Klean 'N Prime®. Allow to dry.
2. Apply a thin coating of Loctite® Thread Sealant to union face.
3. Apply a band of Loctite® Thread Sealant to male threads.
4. Assemble parts snugly.

THREAD SEALING

COMPRESSION FITTINGS

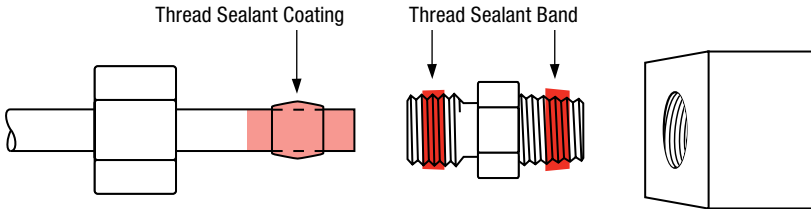

1. Slide fitting nut and ferrule back approximately $\frac{3}{4}$ " from end of tubing.
2. If necessary, spray the entire assembly with Loctite® Klean 'N Prime™. Allow to dry.
Note: Primer is not required for brass parts.
3. Apply a thin coating of Loctite® Thread Sealant to tubing, where ferrule will be located.
4. Slide ferrule forward over Loctite® Thread Sealant coated tubing, then apply a thin bead of Loctite® Thread Sealant coating to ferrule.
5. Slide ferrule forward over Loctite® Thread Sealant coated tubing.
6. Apply a small band of Loctite® Thread Sealant to male threads.
7. Assemble and tighten normally.

Note: Do not use on plastic fittings or tubing.

FLARED/SWAGED FITTINGS

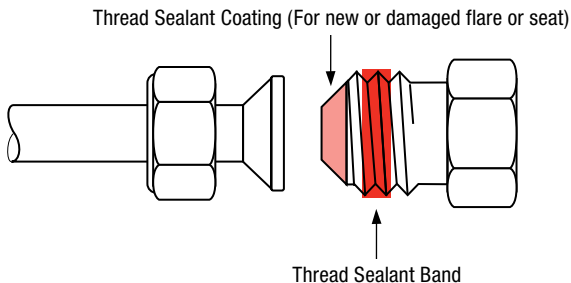

1. Disassemble and, if necessary, spray all components with Loctite® Klean 'N Prime™. Allow to dry.
2. Apply a thin coating of Loctite® Thread Sealant to fitting face.
3. Apply a band of Loctite® Thread Sealant to male threads.
4. Assemble parts snugly.

THREAD SEALING

HOSE ENDS – AIR & HYDRAULIC

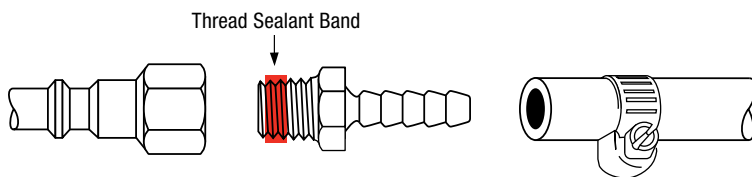

1. If necessary, spray adapter threads with Loctite® Klean 'N Prime™. Allow to dry.
2. Insert barbed hose stem into hose inner diameter (I.D.), with slight twisting motion.
3. Install appropriate hose clamp.
4. Apply a band of Loctite® Thread Sealant to male hose stem threads upon installation or when adding the accessory device. Tighten snugly.

Note: Loctite® Thread Sealant may attack synthetic rubber tubing.

LOCTITE® BRAND THREAD SEALANT QUICK SELECTOR (TAPERED THREADS)

APPLICATION	PRODUCT	PRIMER	INSTANT SEAL	MAX. PRESSURE	STEAM PRESSURE	TEMP. RANGE
Most Metal Fittings	Thread Sealant Stick or Thread Sealant 565™	Klean 'N Prime™	500 psi	10,000 psi (24 hours)	n/a	-65°F to 300°F
High Filtration/Zero Contamination Systems	Thread Sealant 545™ Hydraulic/Pneumatic	Klean 'N Prime™	500 psi (10 min.)	10,000 psi (24 hours)	n/a	-65°F to 300°F
Most Metal Fittings	Thread Sealant 592™- High Temperature	Klean 'N Prime™	500 psi (10 min.)	10,000 psi (24 hours)	n/a	-65°F to 400°F

DO NOT USE THESE PRODUCTS ON OXYGEN OR STRONG OXIDIZERS.

POROSITY SEALING

EXISTING WELD POROSITIES AND CASTINGS

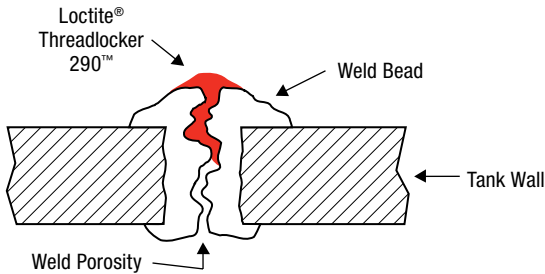

1. IMPORTANT! TAKE PROPER SAFETY PRECAUTIONS IF WORKING WITH FLAMMABLE LIQUID TANKS. AVOID USE WITH COMPRESSIBLE GASSES.
2. Wire brush to remove paint, rust, etc. from repair area.
3. Clean repair area with a cleaner.
4. Apply localized heat to bring repair area to approximately 250°F.
5. Allow repair area to cool to approximately 185°F.
6. Brush or spray sealant on repair area.

- Note:**
- Steel – Use Loctite® Threadlocker 290™ at 185°F.
 - Aluminum/Stainless Steel – Use Loctite® Threadlocker 290™ at 120°F.

- Note:**
- Not recommended for “blowholes”.
 - Maximum porosity sealed – .005”.

7. Allow to cure for 30 minutes (high pressure, above 150 psi — 1 hour).
8. Clean with a cleaner to remove excess sealant. Do not grind.
9. Paint as required.

Note: Casting repair uses the same procedure.

SEALING NEW WELDS — PREVENTIVE MAINTENANCE

1. Remove all slag and scale while hot.
2. Apply sealant when weld is 185°F and falling.
3. Follow information above.

FORM-IN-PLACE GASKETING

SEALING CAST RIGID FLANGES

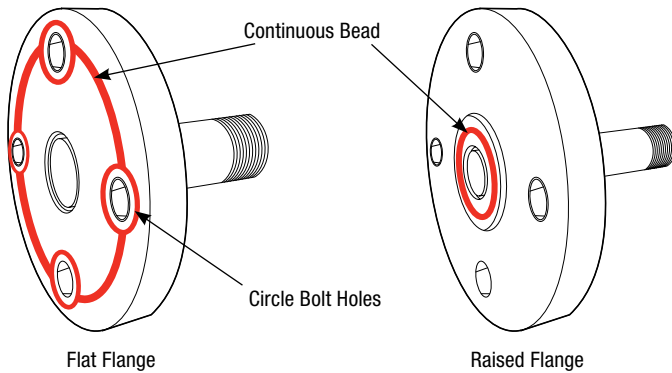

1. Remove old gasketing material and other heavy contaminants. Use mechanical removal technique if required.

Note: Avoid grinding.

2. Clean both flanges with a cleaner.
3. Spray Loctite® Klean 'N Prime™ on only one surface. Allow 1-2 minutes to dry.
4. Apply a continuous bead of Loctite® Gasket Maker to the other surface.

Note: Circle all bolt holes with sealant, if appropriate.

5. Mate Parts. Assemble and tighten as required.

Note: Immediate assembly not required; however avoid delays over 45 minutes.

6. Allow to cure:
 - a. No pressure – immediate service
 - b. Low pressure (up to 500 psi) – 30 to 45 minutes
 - c. High pressure (500 to 2500 psi) – 4 hours
 - d. Extreme high pressure (2500 to 5000 psi) – 24 hours

LOCTITE® BRAND GASKETING QUICK SELECTOR

USE	PRODUCT	GAP FILL	TEMP. RANGE
General	Gasket Maker 518™	.050"	-65°F to 300°F
General	Gasket Maker 515™	.050"	-65°F to 300°F

GASKET DRESSING

SEALED FLANGES

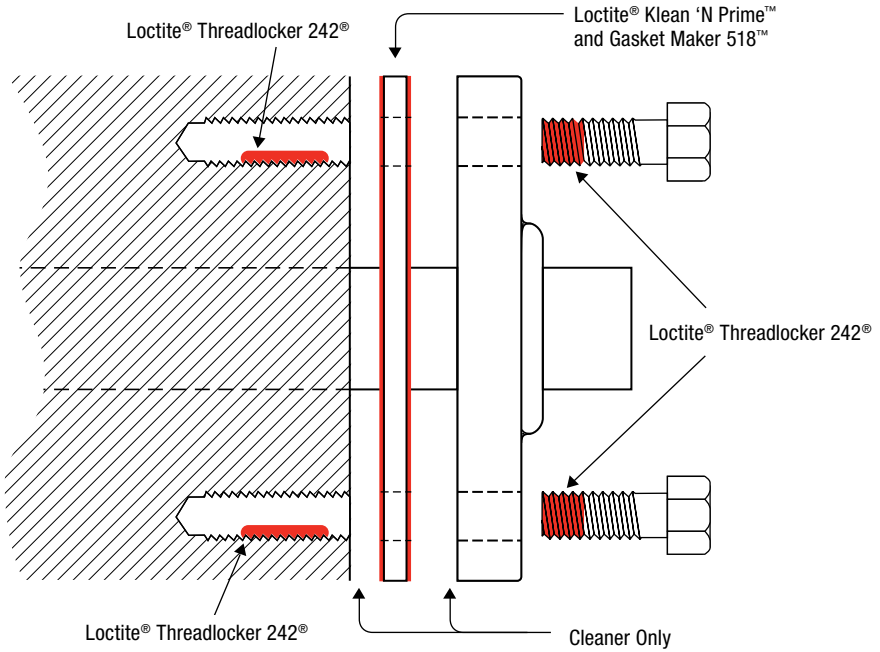

1. Remove old gasketing material and other heavy contaminants. Use mechanical removal technique if required.
2. Clean both flanges with a cleaner.
3. Spray Loctite® Klean 'N Prime™ on both flange faces and both sides of the precut gasket. Allow 1 to 2 minutes to dry.

Note: Avoid grinding.

4. Smear Loctite® Gasket Maker on both sides of precut gasket with a clean applicator.
5. Place coated gasket on flange surface and assemble parts immediately.

Note:

- If cover bolts into blind holes (as above), apply Loctite® Threadlocker **242**® into hole and on threads. Tighten normally.
- If it is a through bolt assembly, apply Loctite® Threadlocker **242**®.

6. Tighten normally.

FORM-IN-PLACE SILICONES

STAMPED OR SHEET METAL FLANGES

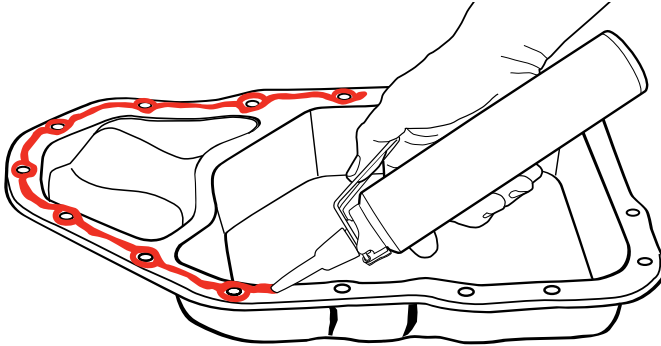

1. Remove old gasketing material and other heavy contaminants.
2. Clean both flanges with a cleaner.
3. Apply a continuous bead of Loctite® Ready Gasket or Loctite® High Performance silicones to sealing surface. Circle all bolt holes.
Note: • Use proper bead diameter to seal flange width and depth.
• Minimize excessive material “squeeze in.”
4. Assemble within 10 minutes by pressing together. Tighten as required.
5. Clean up any excess or squeeze out.
6. Cure times will vary with temperature, humidity and gap. Typical full cure time is 24 hours.

	LOCTITE® READY GASKET*	LOCTITE® 587™ BLUE
Color	Black	Blue
VISCOSITY, cP	Paste	Paste
GAP FILL	¼"	¼"
Cure Method	Moisture/Oxime	Moisture/Oxime
CURE SPEED		
Tack-Free	30 minutes	30 minutes
Full Cure	24 hours	24 hours
SERVICE TEMP. RANGE		
Intermittent	-75°F to 500°F -59°F to 260°C	-75°F to 500°F -59°F to 260°C

*Loctite® Ready Gasket provides a low pressure instant seal (100 psi at zero gap).

STRENGTHEN KEYED ASSEMBLIES

STANDARD DUTY

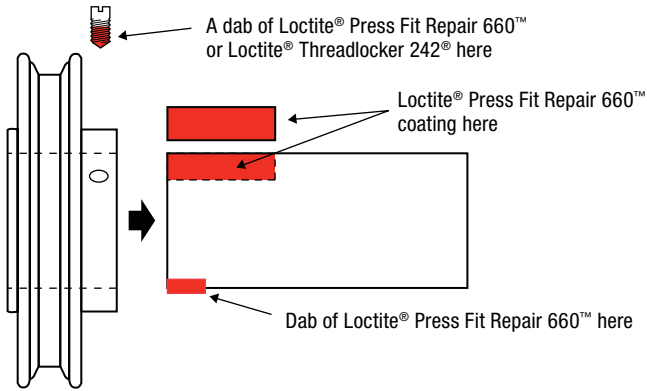

ASSEMBLY

1. Clean all parts with a cleaner.
2. If necessary, spray all parts, inner diameter (I.D.) and outer diameter (O.D.), with Loctite® Klean 'N Prime™.
3. Apply a coating of Loctite® Press Fit Repair 660™ into keyway and on key.
4. Apply dab(s) of Loctite® Press Fit Repair 660™ onto shaft opposite keyway or evenly spaced around shaft.
5. Assemble parts. Wipe off excess.
6. Apply a dab of Loctite® Press Fit Repair 660™ to set screw.
7. Tighten set screw.
8. Allow 5 to 10 minutes prior to service.

Note:

- Loctite® Press Fit Repair 660™ is NOT recommended for radial gaps exceeding .010" on shaft or keyway.
- See REPAIRING BADLY WALLOVED KEYWAY on page 18 for procedure.

DISASSEMBLY

1. Tap component and key with hammer.
2. Pull as usual.

STRENGTHEN KEYED ASSEMBLIES

HEAVY DUTY

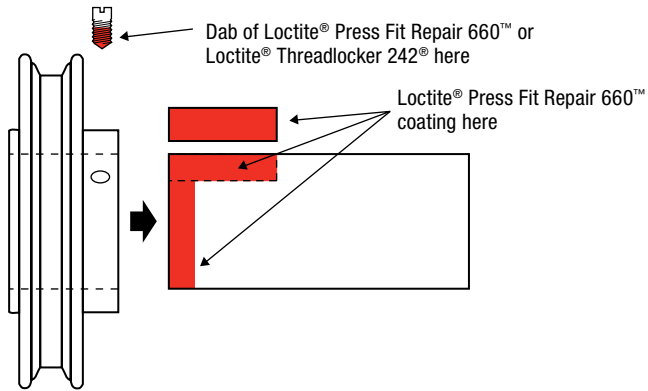

ASSEMBLY

1. Clean all parts with a cleaner.
2. Apply a Loctite® Press Fit Repair **660™** coating around shaft, into keyway, and on key.
3. Assemble parts. Wipe off excess.
4. Apply a dab of Loctite® Press Fit Repair **660™** to screw.
5. Tighten set screw.
6. Allow 30 minutes prior to service.

- Note:**
- If gap exceeds .005", use Loctite® Klean 'N Prime™ on appropriate area (shaft or keyway).
 - Loctite® Press Fit Repair **660™** is NOT recommended for radial gaps exceeding .010" on shaft or keyway.
 - See REPAIRING BADLY WALLOVED KEYWAY for procedure.

DISASSEMBLY

1. Tap component and key with hammer.
2. If necessary, apply localized heat (500°F for five minutes).
3. Pull while hot.

STRENGTHEN KEYED ASSEMBLIES

REPAIRING BADLY WALLOWED KEYWAY

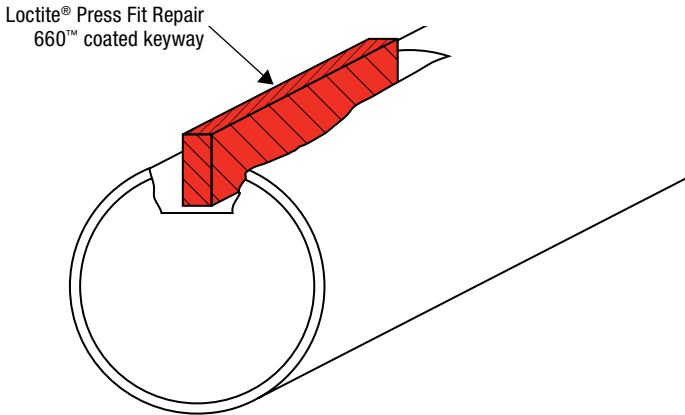

1. Clean all parts with a cleaner.
2. If necessary, spray all parts with Loctite® Klean 'N Prime™. Allow to dry.
3. Apply a Loctite® Press Fit Repair **660™** coating into keyway.
4. Assemble as required using Loctite® Press Fit Repair **660™**.
5. Allow 30 to 60 minute cure time.

- Note:**
- Loctite® Press Fit Repair **660™** is NOT recommended for lateral gaps exceeding .010".
 - Higher strengths are obtained by NOT using Loctite® Klean 'N Prime™ with small (.002" to .004") gap, and allowing longer cure (4 to 24 hours).

SHAFT MOUNTED ASSEMBLIES

REPAIRING BADLY WORN SHAFT

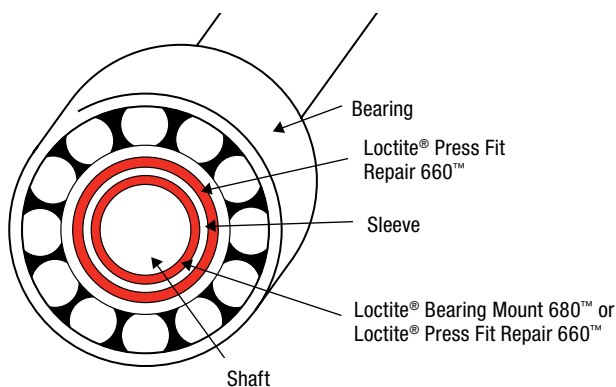

1. Determine a minimum radial gap.
2. Select and trim appropriate sleeve to allow component slip fit.
3. Roughen sleeve O.D. with emery cloth.
4. Clean all parts with a cleaner.
5. Apply a Loctite® Bearing Mount **680™** or Loctite® Press Fit Repair **660™** coating around the shaft.
6. Install sleeve.
7. Apply a coating of Loctite® Press Fit Repair **660™** to sleeve O.D.
8. Install component as required onto sleeved shaft.
9. Allow 30 to 60 minute cure.

- Note:**
- Loctite® Press Fit Repair **660™** is NOT recommended for radial gaps exceeding .010".
 - Higher strengths are obtained by NOT using Loctite® Klean 'N Prime™ with small (.002" to .004") gap, and allowing longer cure (4 to 24 hours).

SHAFT MOUNTED ASSEMBLIES

SLIP FIT – LIGHT/HEAVY DUTY

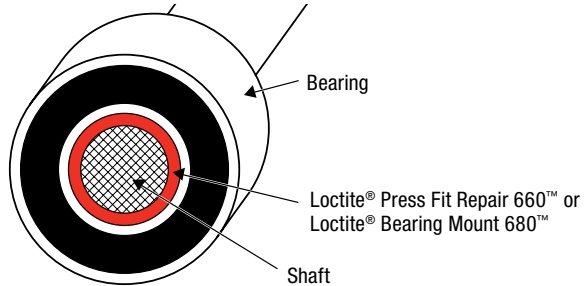

ORIGINAL

1. Machine shaft to .002" radial slip fit with 50-80 rms finish (second cut).
2. Clean all parts with a cleaner.
3. Spray all parts (I.D. and O.D.) with Loctite® Klean 'N Prime™. Do NOT use primer for heavy duty applications.
4. Apply a Loctite® Press Fit Repair **660™** coating around shaft and engagement area.
5. Assemble parts with rotating motion.
6. Wipe off excess.
7. Allow 2 hours prior to service.

WORN SHAFT

Follow directions above except:

1. Determine radial gap.
2. If radial gap exceeds .005", Loctite® Klean 'N Prime™ must be used.
3. Take steps to maintain concentricity with large gaps.
4. Larger gaps require longer cure times (30 to 60 minutes).
5. Loctite® Press Fit Repair **660™** is NOT recommended for radial gaps exceeding .010".
6. See procedure for BADLY WORN SHAFT on page 19.

Note: Loctite® Press Fit Repair **660™** is very fast fixturing (30 seconds or less) with Loctite® Klean 'N Prime™.

MAXIMUM STRENGTH

1. Same as above, except use Loctite® Bearing Mount **680™** with Loctite® Klean 'N Prime™ or no primer.
2. Allow 4 to 24 hours to cure.

MAXIMUM TEMPERATURE (400°F CONTINUOUS)

1. Same as above, except use Loctite® Bearing Mount **620™** or Loctite® Sleeve Retainer **640™** with Loctite® Klean 'N Prime™.

SHAFT MOUNTED ASSEMBLIES

PRESS FIT

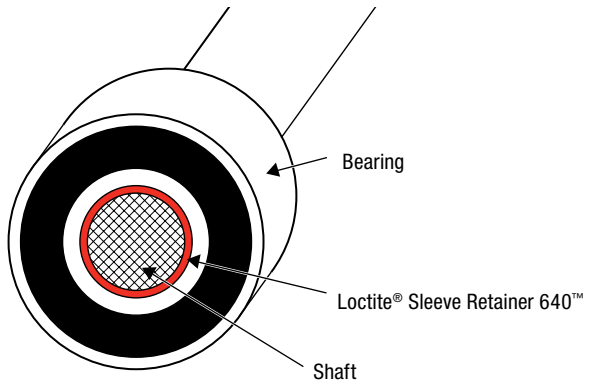

STANDARD

1. Clean shaft O.D. and component I.D.
2. Apply a bead of Loctite® Sleeve Retainer **640™** to the circumference of the shaft at leading edge of insertion or leading area of engagement.

Note: • Bearing Mounts will always be squeezed to the outside, when applied to shaft.

- Do NOT use with Loctite® Anti-Seizes or similar products.

3. Press as usual. Wipe off excess.
4. No cure time required.

Note: Loctite® Sleeve Retainer **640™** is used due to low viscosity and wetting properties.

TANDEM MOUNT

1. Apply bearing mount to the bore of the inside component.
2. Continue assembly as above.

SHAFT MOUNTED ASSEMBLIES

SHRINK FIT

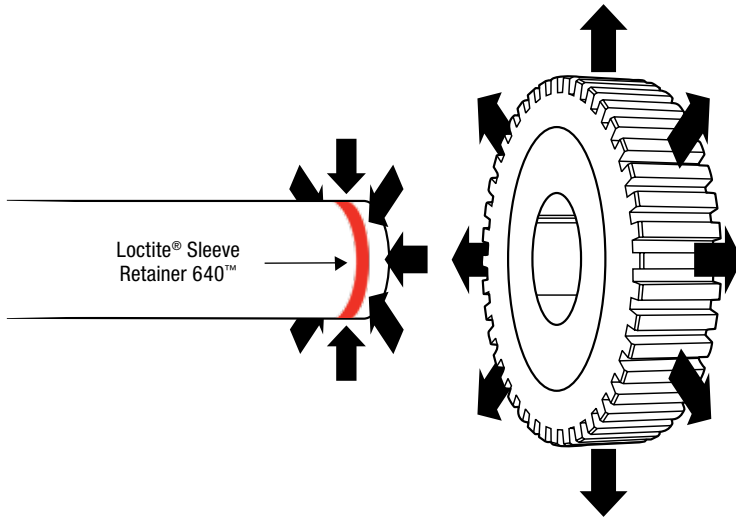

ASSEMBLY

1. Clean the shaft O.D. and component I.D.
2. Cool the shaft to cause contraction, or heat the component to cause expansion.
3. Apply a brush film of Loctite® Sleeve Retainer 640™ to the shaft or lower temperature part.
4. Install component and allow temperatures to equilibriate.
5. Wipe off excess.

Note: Loctite® Retaining Compound will add lubricity for easier assembly, while sealing and protecting the bond area from environmental exposure and filling gaps for a more complete contact area.

HOUSED COMPONENTS

SLIP FIT

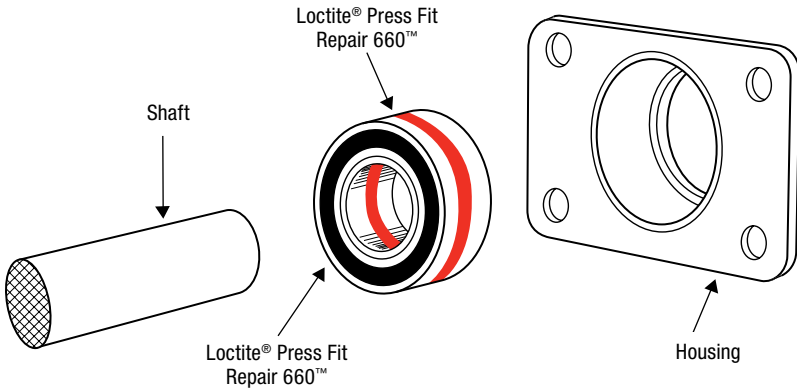

ORIGINAL

1. Select component to fit shaft.
2. Machine to reduce component O.D. or increase housing I.D. to permit approximate .002" to .004" diametral slip fit.
3. Clean all parts with a cleaner and spray with Loctite® Klean 'N Prime™.
4. Apply Loctite® Press Fit Repair **660™** to component O.D.
5. Install component. Do not rotate.
6. Wipe off excess.
7. Allow five minutes prior to service.

WORN

Procedures identical to original slip fit, except:

1. Determine the maximum radial gap.
2. If the maximum gap exceeds .005", Loctite® Klean 'N Prime™ must be used.
3. Take steps to maintain concentricity on large gaps.
4. Large gaps require longer cure times (30 to 60 minutes).
5. Loctite® Press Fit Repair **660™** is NOT recommended for radial gaps exceeding .020".

HOUSED COMPONENTS

SEALING/RETAINING — METALLIC SEAL

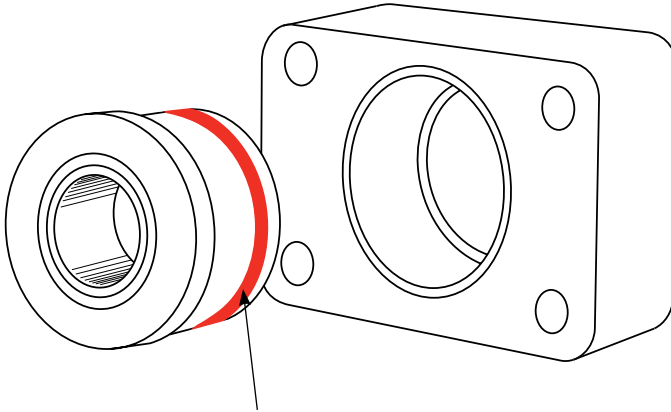

Bead of Loctite® Threadlocker 243™

1. Clean the housing I.D. and seal O.D. with a cleaner.
2. Spray both the housing and seal with Loctite® Klean 'N Primer™.
3. Apply a bead of Loctite® Threadlocker **243™** or Loctite® Blue Threadlocker Stick to the leading edge of metallic seal O.D.

Note: Virtually any Loctite® Threadlocking product will work here. Medium strength liquid is recommended due to normal gap and strength requirement.

4. Install as usual.
5. Wipe off excess.
6. Allow to cure 30 minutes.

Note: • Loctite® Threadlocker **243™** or Loctite® Blue Threadlocker Stick is normally used with worn seal housings to prevent leakage or slippage.

- It is not generally necessary to remove pre-applied sealant from seal O.D.

RETAINING COMPOUNDS

LOCTITE® RETAINING COMPOUNDS QUICK SELECTOR

APPLICATION	LOCTITE® PRODUCT	LOCTITE® PRIMER
Shaft Mount – Press Fit		
Medium Strength	Sleeve Retainer 640™	NONE
	Sleeve Retainer 640™	Klean 'N Prime™
Shaft Mount – Shrink Fit		
Medium Strength	Sleeve Retainer 640™	NONE
Shaft Mount – Slip Fit		
Small Gap (.002" Radial max.)	Sleeve Retainer 640™	Klean 'N Prime™
Larger Gap (.010" Radial max.)	Press Fit Repair 660™	Klean 'N Prime™
Maximum Strength (.010" Radial max.)	Bearing Mount 680™	Klean 'N Prime™
Maximum Temperature (400°F) (.008" Radial max.)	Bearing Mount 620™	Klean 'N Prime™
Housing Mount – Press Fit		
Maximum Strength	Sleeve Retainer 640™	NONE
Low Strength	Threadlocker 243™	NONE
Housing Mount – Slip Fit		
Maximum Strength	Bearing Mount 680™	NONE
High Strength	Press Fit Repair 660™	NONE
Controlled Strength	Press Fit Repair 660™	Klean 'N Prime™
Low Strength	Threadlocker 243™	Klean 'N Prime™
	Blue Threadlocker Stick	

- Note:**
- Softer metals (Aluminum, Bronze, etc.) provide lower shear strengths than ferrous components.
 - Excessive gap reduces shear strengths.
 - Ideal surface finish — 50 to 80 rms.

Refer to Technical Data Sheets for more information.

DISASSEMBLY

THREADLOCKING, THREAD SEALING AND RETAINING

LOW AND MEDIUM STRENGTH PRODUCTS

Disassemble with hand tools.

HIGH STRENGTH PRODUCTS

- Apply localized heat (500°F or higher) to assembly for 5 minutes.
- Disassemble with hand tools while hot.

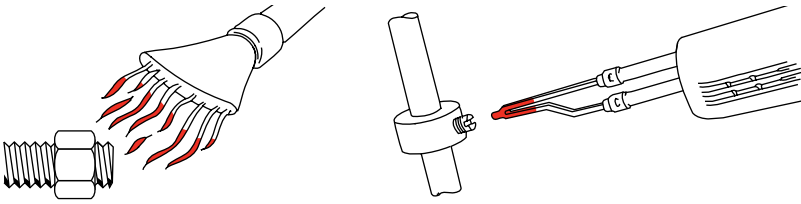

GASKETING

- Disassemble flange using hand tools. Remove material with a gasket remover.

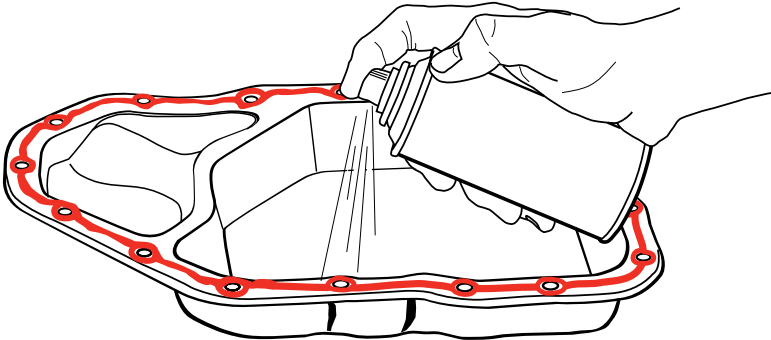

RUSTPROOFING

OPTIMUM USE OF LOCTITE® EXTEND® RUST TREATMENT

SURFACE PREPARATION — OLD STEEL:

Loose or “flaky” rust must be removed. Only conversion of firmly bonded rust will result in durable protection. Oil, grease, old paint, mill scale, form oil, fingerprints, water soluble surfaces and chlorides must be removed to allow Loctite® Extend® Rust Treatment to react with rust. Ideal surfaces will show light rust as well as bare metal surfaces.

RUST CONVERSION TIME AND APPEARANCE:

Two coats of Loctite® Extend® Rust Treatment are recommended. The first coat should develop a purple-black color within seconds. The second coat should dry to a black color. The second coat should be applied within 15-30 minutes of the first coat.

APPLICATION CONDITIONS:

Loctite® Extend® Rust Treatment may be applied when surface and air temperatures are between 50°F and 90°F. Reaction is slower at lower temperatures. If temperature is too hot, film may surface dry and bubble. High humidity is beneficial; it slows drying but assists rust conversion. Loctite® Extend® Rust Treatment should not be applied in conditions of condensing humidity (e.g. fog, dew), on ice, in rain or in heavy sea (salt) spray atmospheres. Steel surface may be damp but not wet (i.e. continuous visible film of water). **DO NOT APPLY LOCTITE® EXTEND® RUST TREATMENT TO SURFACES IN DIRECT SUNLIGHT.**

APPLICATION EQUIPMENT METHODS:

Loctite® Extend® Rust Treatment may be applied by brush, roller or spray. Brush or roller is suitable for small areas. Avoid sags and ridges and keep edges wet by coating about a square yard at a time. Roll away from previously coated area and then roll back. Do not pour unused material back into the original container. **NEVER** add solvents to Loctite® Extend® Rust Treatment.

Spray application is recommended for larger areas. Airless spray equipment is faster, and provides more effective conversion due to improved surface penetration. Conventional air-spray equipment may be used, but Loctite® Extend® Rust Treatment may require thinning up to 10% with water for proper spraying.



TROUBLESHOOTING

CHECKLIST

1. What type of failure is occurring? Has the application worked before?
2. Was proper and adequate adhesive/sealant used?
3. Was proper and adequate primer/activator used?
4. Do service conditions exceed the capability of the adhesive sealant?
(a) operating temperature (c) fluid compatibility
(b) excessive pressure too soon (d) impact on environment
5. Were parts adequately cleaned prior to applying adhesive?
Note: If adhesive failure, is cured residue on one or both parts?
If one part is bare, check that part for contamination.
6. Were proper assembly techniques utilized?
7. Was adhesive/sealant allowed adequate cure time prior to service?
8. Do assembly/part conditions exceed capability of the adhesive/sealant?
(a) excessive gaps (c) improper joint design
(b) component materials (d) inadequate clamping/fixturing
9. If additional assistance is required, please call our HENKEL TECHNICAL INFORMATION LINE. See back cover for the Henkel Technical Information number in your area.

ORDERING

PRODUCT LISTING/ORDER INFORMATION

LOCTITE® GASKETING PRODUCTS	SIZE	ITEM NO.
Gasket Maker 515™	50 ml tube	38655
Gasket Maker 518™	50 ml tube	37394
	300 ml cartridge	37530
Ready Gasket	5 oz. cartridge	37512
	7 oz. can	37510
	190 ml power can	40480
RTV 587™ Blue Silicone Gasket Maker	80 ml tube	37465
	190 ml power can	40462
	300 ml cartridge	37516
RTV 598™ Black Silicone Gasket Maker	8.75 oz. can	37519
	11 ml tube	37472
	80 ml tube	37467
	190 ml power can	40463
	300 ml cartridge	37518
RTV 5920™ Copper Silicone Gasket Maker	80 ml tube	37466
RTV 5699™ Grey Silicone Gasket Maker	80 ml tube	37464
	190 ml power can	40505
LOCTITE® GENERAL MAINTENANCE PRODUCTS	SIZE	ITEM NO.
Extend® Rust Treatment	1 qt. bottle	75430
	10.25 oz. aerosol	633877
	8 fl. oz. bottle	1381192
Form-A-Thread Stripped Thread Repair	12.9 ml	28654
LOCTITE® PRIMERS	SIZE	ITEM NO.
Klean 'N Prime™	4.5 oz. aerosol	37509
LOCTITE® RETAINING COMPOUNDS	SIZE	ITEM NO.
Bearing Mount 620™ – High Temperature	36 ml bottle	38652
Sleeve Retainer 640™ – High Strength	6 ml tube	37424
	36 ml bottle	37484
Press Fit Repair 660™ – For Worn Parts	50 ml tube	38651
Bearing Mount 680™ – Relaxed Fits	36 ml bottle	37485

ORDERING

PRODUCT LISTING/ORDER INFORMATION

LOCTITE® THREADLOCKERS	SIZE	ITEM NO.
Threadlocker 222™ – Low Strength	6 ml tube	38653
Threadlocker 242® – Medium Strength	6 ml tube	37418
	36 ml bottle	37477
Threadlocker 243™ – Medium Strength	6 ml tube	1330799
Blue Threadlocker Stick – Med. Strength	9 g stick	37643
	19 g stick	37614
Quicktape® 249™ Threadlocker Tape – Med. Strength	260" Roll	1372603
Threadlocker 262™ – High Strength	6 ml tube	37420
	36 ml bottle	37478
Threadlocker 271™ – Heavy Duty	0.5 ml ampule	27105
	6 ml tube	37421
	36 ml bottle	37479
Threadlocker 272™ – High Strength	36 ml bottle	37480
Red Threadlocker Stick – High Strength	9 g stick	37701
	19 g stick	37700
Threadlocker 277™ – Heavy Duty/Large Bolts	36 ml tube	38656
Threadlocker 290™ – Penetrating	6 ml bottle	37423
	36 ml bottle	37481
LOCTITE® THREAD SEALANTS	SIZE	ITEM NO.
Thread Sealant 545™ – Pneumatic/Hydraulic	36 ml bottle	37482
Thread Sealant Stick – High Performance	19 g stick	37615
Thread Sealant 565™ – High Performance	50 ml tube	37396
Thread Sealant 592™ – High Temperature	6 ml tube	37398
	50 ml tube	37397