

INSTALLATION INSTRUCTIONS AND PARTS LIST

MODEL 583054, 583060, 584054 O-MEGA II 6" OVAL STEPS

1. READ INSTRUCTIONS COMPLETELY AND CHECK TO MAKE SURE THAT ALL REQUIRED PARTS (LISTED ON THE SERVICE PARTS LIST) ARE ON HAND BEFORE STARTING THE INSTALLATION.
2. FOLLOW THE INSTRUCTIONS INCLUDED WITH THE SPECIFIC BRACKET PACKAGE THAT YOU ARE USING, TO MOUNT THE BRACKETS TO YOUR VEHICLE.
3. BEFORE ATTACHING THE O-MEGA STEPS TO THE BRACKETS, PLACE THE STEP PADS (ITEM #2) ON TOP OF THE STEP PLATES. USE THE TABLE ON SHEET #2, AS A GUIDE TO POSITION THE STEP PAD FOR YOUR PARTICULAR VEHICLE. WHEN INSTALLING THE PADS ON THE STEPS, DRILL (5) 1/8" HOLE USING THE STEP PAD AS A GUIDE. ATTACH WITH (5) 8-18X1/2" TEK SCREWS (ITEM #6) PROVIDED. REPEAT FOR ALL STEP PADS.
4. INSTALL THE REQUIRED NUMBER OF SQUARE HEAD BOLTS INTO THE DESIGNATED SLOTS IN THE BOTTOM OF THE STEP PLATES.
5. INSTALL THE END CAPS (ITEM #3) AS SHOWN IN *fig. 1* SNUG UP THE NUTS. BE CAREFUL NOT TO DEFORM THE PLASTIC
6. POSITION THE O-MEGA STEP ON THE MOUNTING BRACKETS SO THAT THE SQUARE HEAD SCREWS (ITEM #4) ARE LOCATED IN THE SLOTS OF THE MOUNTING BRACKETS AND THE STEP IS CENTERED, FRONT TO REAR, ON THE VEHICLE. INSTALL 5/16" SERRATED FLANGE NUTS (ITEM #5) ON THE SQUARE HEAD SCREWS (ITEM #4) AND TIGHTEN TO 19 LB FT.

SERVICE PARTS LIST

ITEM	PART NO.	QTY	DESCRIPTION
1	553069	2	EXTRUSION-AL,51.0,OMEGA STP,SILVER
1	553057	2	EXTRUSION-AL,51.0,OMEGA STP,BLACK
1	553070	2	EXTRUSION-AL,57.0,OMEGA STP,SILVER
2	552970	4	ALUM,STP-PAD,BLK,OMEGA-STEPS
3	107956	4	CAP-END,PLSTC,2.95 X 6.70
4	106880	20	SCREW-SQ HD,5/16-18 X 1,MAGNIGUARD
5	102680	20	NUT-SERR FLG,HX,SST,WX,5/16-18
6	107958	20	SCREW-PPH,TEK,#8-18 X 1/2",SST,BZP



STEP PAD LOCATION GUIDE

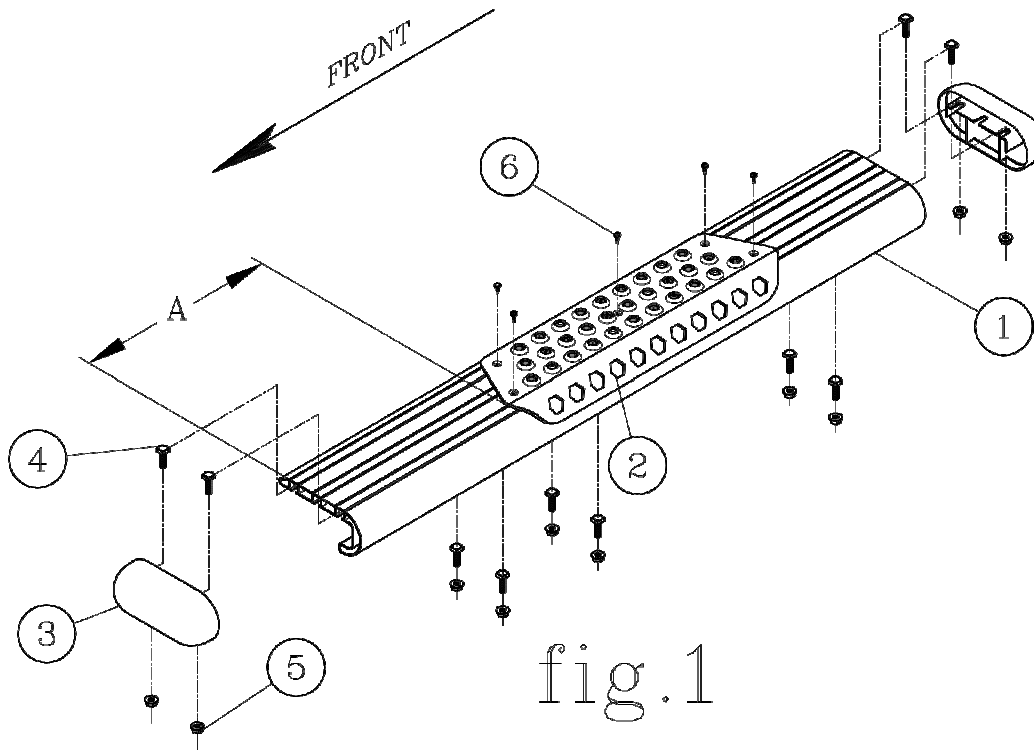

fig.1

VEHICLE MODEL	PAD A	PAD B
SILVERADO/SIERRA REGULAR CAB	14-3/4	N/A
DODGE RAM REGULAR CAB	10-1/2	N/A
FORD F150 REGULAR CAB	18-1/4	N/A
FORD SUPER DUTY REGULAR CAB	6-7/8	N/A
TUNDRA REGULAR CAB	6-1/2	N/A
TOYOTA FJ CRUSIER	6-1/2	N/A
FORD ESCAPE	5-1/2	35-1/2

NOTE: THE ABOVE PAD LOCATIONS ARE ONLY SUGGESTIONS AND MAY BE PLACED AT THE PURCHASERS DISCRETION. (THE 2008-2012 FORD ESCAPE WILL USE 2 PADS PER SIDE ON THE 585060 BOARDS).



INSTALLATION INSTRUCTIONS AND PARTS LIST

APPLICATION: **MODEL 571631 SES, MEGA/OMEGA STEP BRACKET KIT:**

2009+ DODGE RAM 1500 REGULAR CAB PICKUPS

2010+ DODGE RAM HD REGULAR CAB PICKUPS, & CHASSIS CABS.

1. READ INSTRUCTIONS COMPLETELY AND CHECK TO MAKE SURE THAT ALL REQUIRED PARTS (LISTED ON THE SERVICE PARTS LIST) ARE ON HAND BEFORE STARTING THE INSTALLATION.
2. ATTACH THE MOUNTING BRACKETS TO THE VEHICLE AS FOLLOWS:

RAM TRUCKS WITH THREADED INSERTS IN THE ROCKER PANEL.

- 2.1 PLACE THE DRIVERS SIDE FRONT BRACKET (ITEM #1) UP TO THE PINCHWELD SO THAT THE LOWER MOUNTING FLANGE IS TO THE OUTSIDE OF THE PINCHWELD, ALIGN THE TWO RECTANGULAR HOLES OF THE LOWER MOUNTING FLANGE OF (ITEM #1) WITH THE TWO OBOURD HOLES IN THE PINCHWELD, INSERT THE TWO 1/4-20 X 1" CARRIAGE BOLTS (ITEM #5) THROUGH THE LOWER MOUNTING FLANGE AND THEN THROUGH THE PINCHWELD, PLACE A 1/4" FLAT WASHER (ITEM #6), AND 1/4-20 FLANGE NUT (ITEM #7) ON TO THE CARRIAGE BOLTS, LEAVE FINGER TIGHT. **SEE FIGURES 1 & 2.**
- 2.2 INSERT AN M8 X 25mm SCREW (ITEM # 8) WITH A 5/16" FLAT WASHER (ITEM #9) THROUGH THE SLOTS ON THE UPPER MOUNTING FLANGE, LEAVE FINGER TIGHT.
- 2.3 REPEAT STEPS 2.1 & 2.2 ON THE REAR (ITEM #3) BRACKETS.
- 2.4 FOR THE PASSENGER SIDE THE INSTALLATION IS A MIRROR IMAGE OF THE DRIVERS SIDE, USE (ITEM #2) FOR THE FRONT BRACKET, & (ITEM #4) FOR THE REAR BRACKET.

RAM TRUCKS WITHOUT THREADED INSERTS IN THE ROCKER PANEL.

- 2.5 ON THE VERTICAL WALL OF THE ROCKER PANEL, INSTALL THE T-BOLT WELDMENT (ITEM #11) INTO THE LARGE OBOURD HOLE INSERTING THE NUT END FIRST, LEAVING THE THREADED STUD STICKING OUT OF THE OBOURD HOLE. **BE CAREFULL NOT TO DROP THE T-BOLT INSIDE OF THE ROCKER PANEL.** ATTACH THE FLAT PLASTIC BOLT RETAINER (ITEM #12) TO THE THREADED STUD OF THE T-BOLT. (THIS IS TO KEEP THE T-BOLT FROM FALLING INTO THE ROCKER PANEL.)
- 2.6 PLACE THE DRIVERS SIDE FRONT BRACKET (ITEM #1) UP TO THE PINCHWELD SO THAT THE LOWER MOUNTING FLANGE IS TO THE OUTSIDE OF THE PINCHWELD, ALIGN THE TWO RECTANGULAR HOLES OF THE LOWER MOUNTING FLANGE OF (ITEM #1) WITH THE TWO OBOURD HOLES IN THE PINCHWELD, INSERT THE TWO 1/4-20 X 1" CARRIAGE BOLTS (ITEM #5) THROUGH THE LOWER MOUNTING FLANGE AND THEN THROUGH THE PINCHWELD, PLACE A 1/4" FLAT WASHER (ITEM #6), AND 1/4-20 FLANGE NUT (ITEM #7) ON TO THE CARRIAGE BOLTS, LEAVE FINGER TIGHT. **SEE FIGURES 3 & 4.**
- 2.7 PLACE A FLAT WASHER (ITEM #9), AND AN M8 FLANGE NUT (ITEM #10), ON THE THREADED STUD OF THE T-BOLT (ITEM #11) LEAVE FINGER TIGHT.
- 2.8 ROTATE THE T-BOLT SO THAT THE THREADED NUT IS VISIBLE THROUGH THE SLOTTED HOLE IN THE UPPER MOUNTING FLANGE, INSERT AN M8 X 25mm SCREW (ITEM #8) WITH A 5/16" FLAT WASHER (ITEM #9), LEAVE FINGER TIGHT.
- 2.9 REPEAT STEPS 2.5 THRU 2.8 ON THE REAR (ITEM #3) BRACKETS.
- 2.10 FOR THE PASSENGER SIDE THE INSTALLATION IS A MIRROR IMAGE OF THE DRIVERS SIDE, USE (ITEM #2) FOR THE FRONT BRACKET, & (ITEM #4) FOR THE REAR BRACKET.

NOTE: 2009 TO 2012 TRUCKS DO NOT HAVE THE OBOURD HOLES IN THE PINCH WELD, THEY WILL REQUIRE DRILLING (2) 5/16" HOLES FOR EACH BRACKET, TO GET THE PROPER LOACTION FOR DRILLING FOLOW STEP 2.5, AND THEN SKIP TO STEP 2.7 & 2.8, WITH THE BRACKET IN PLACE, NOW MARK THE PINCHWELD FOR DRILLING.

3. INSTALL THE STEP PLATES, AND ADJUST BRACKETS, AND BOARDS BEFORE TIGHTENING ALL THE FASTENERS.



SERVICE PARTS LIST

ITEM	PART NO.	QTY	DESCRIPTION
1	553006	1	BRKT-MTG, WLDMNT, FRONT LH, 571632
2	553007	1	BRKT-MTG, WLDMNT, FRONT RH, 571632
3	553008	1	BRKT-MTG, WLDMNT, REAR LH, 571632
4	553009	1	BRKT-MTG, WLDMNT, REAR RH, 571632
5	101320	8	BLT-CRG, 1/4-20 X 1.00", SST, BLK, EM6219
6	101370	8	WSHR-FL, SST, .281 X .625 X .065
7	102366	8	NUT-FLG, HEX, 1/4-20, SST
8	102549	8	SCR-HEX HD, M8 X 1.25 X 25mm, ZP
9	100034	8	WSHR-FL, 5/16, ZP
10	105859	4	NUT HEX-FLG, M8 X 1.25, ZP
11	553012	4	T-BOLT WELDMNT, ZP, 571632
12	101572	4	BOLT RETAINER-PLASTIC, 8mm

SERVICE PARTS LIST

BRACKET NO. - 571631

Fig.1

INSTALLATION ON ROCKER
PANELS WITH THREADED
INSERTS

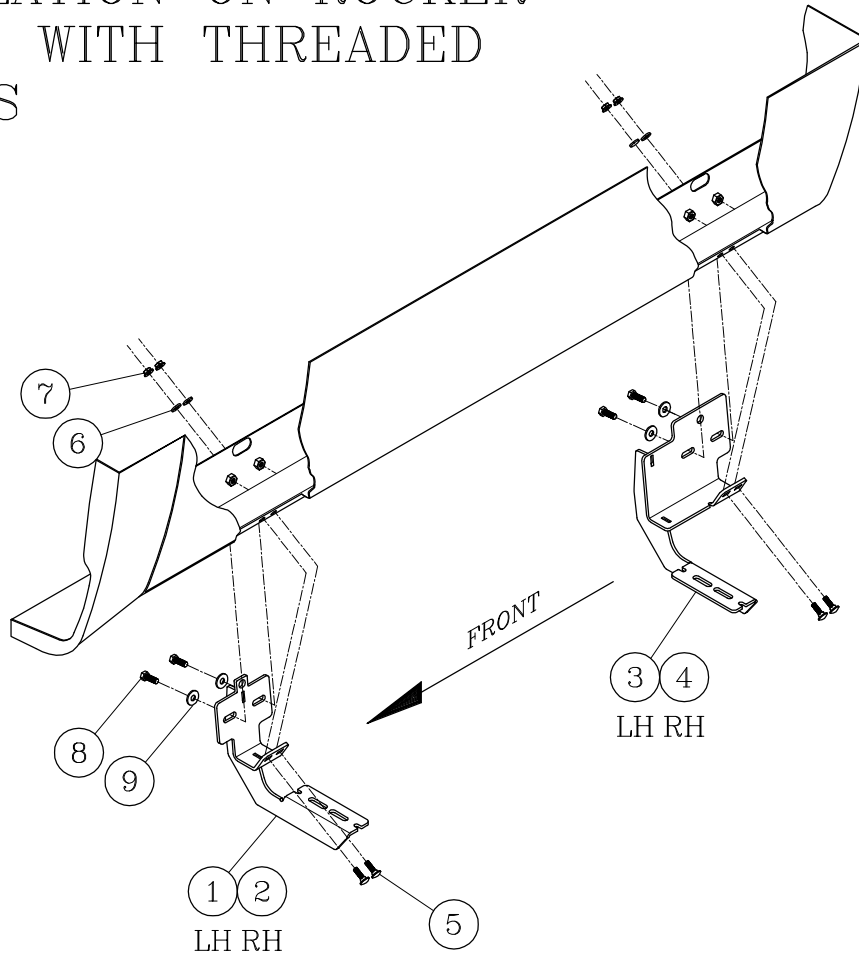

LEFT (DRIVER) SIDE SHOWN
-RIGHT (PASSENGER) SIDE OPPOSITE-

Fig.2

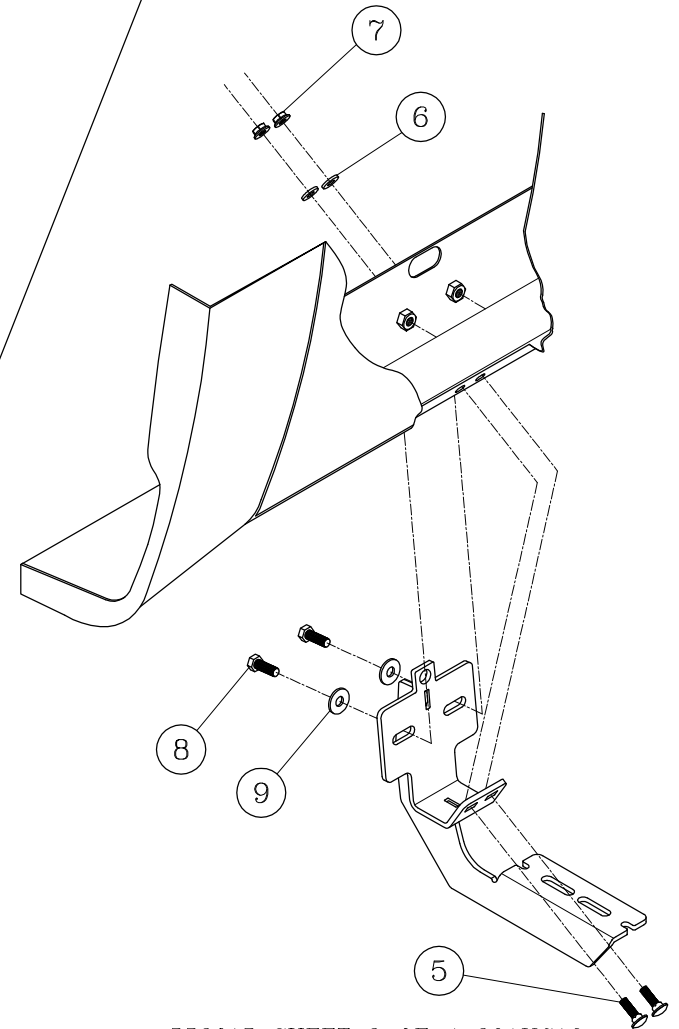

SERVICE PARTS LIST

BRACKET NO. - 571631

Fig.3

INSTALLATION ON ROCKER
PANELS WITHOUT
THREADED INSERTS

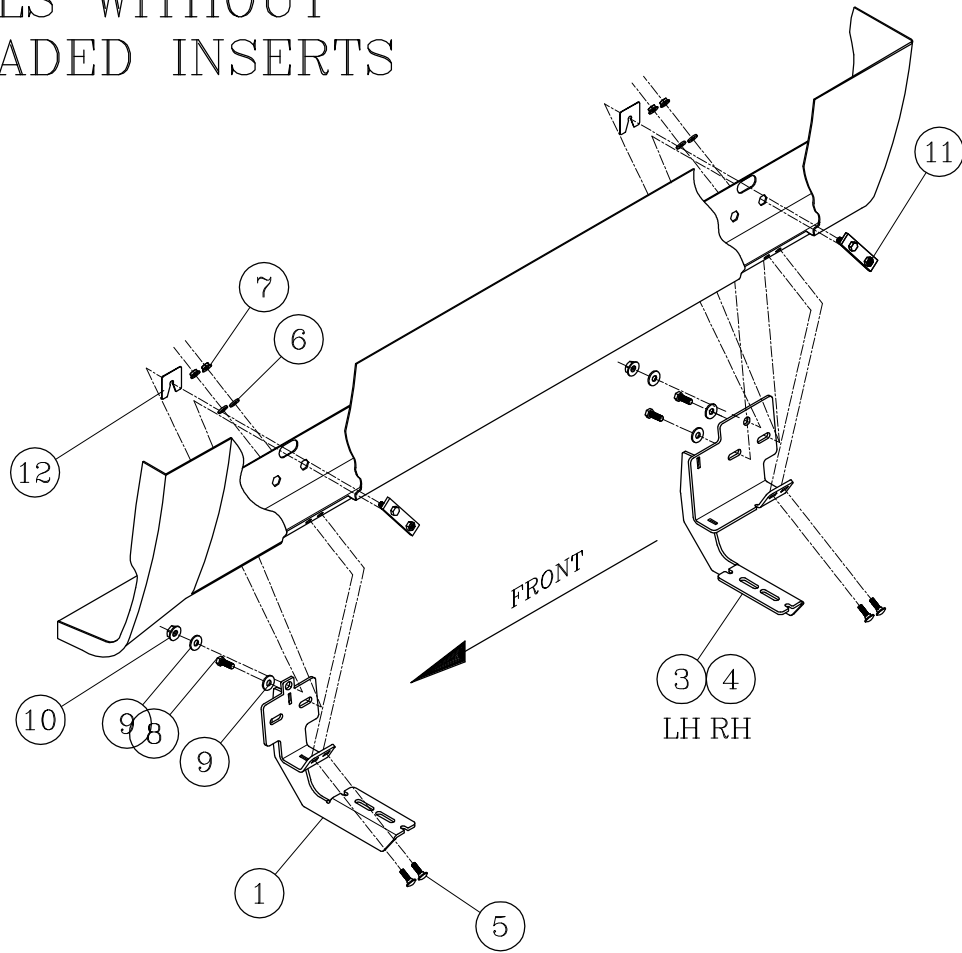

LEFT (DRIVER) SIDE SHOWN
-RIGHT (PASSENGER) SIDE OPPOSITE-

Fig.4

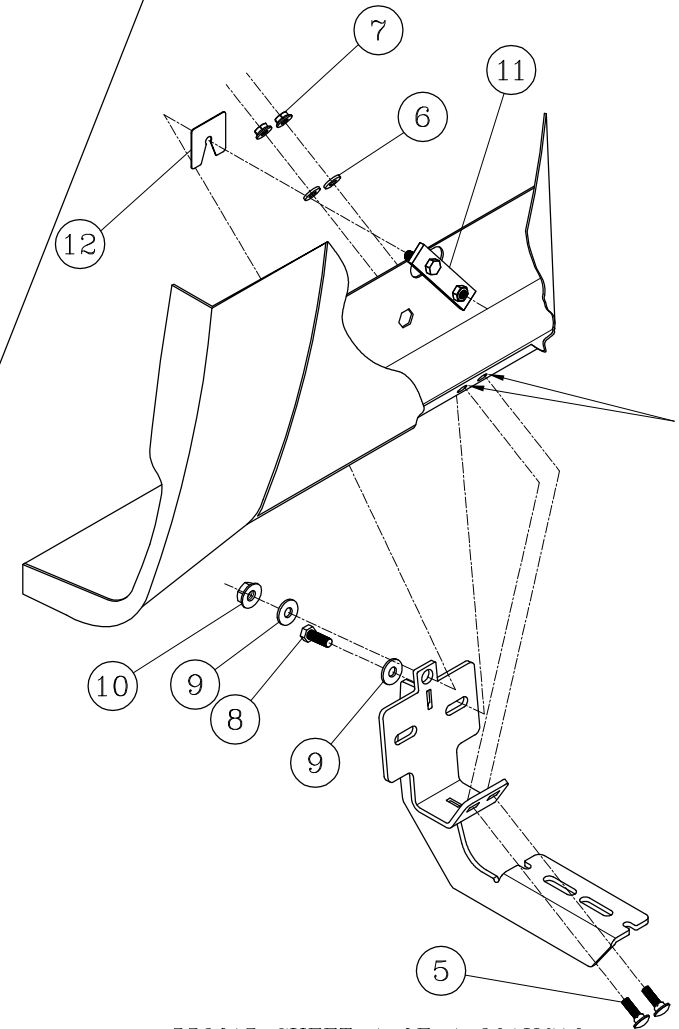

NOTE: 2009-12 WILL REQUIRE DRILLING THESE HOLES IN THE PINCHWELD.

