



INSTALLATION INSTRUCTIONS



FORD F-150

PART NO. 19572

BILL OF MATERIALS:

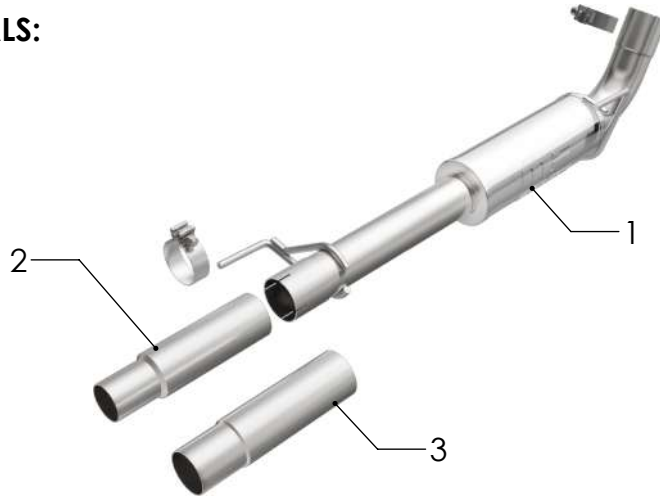

- 1. MUFFLER ASSEMBLY
- 2. INLET PIPE '15 - '20
- 3. INLET PIPE 2021



WEAR SAFETY GLASSES



READ INSTRUCTIONS THOROUGHLY BEFORE INSTALLING PRODUCT



SPRAY LUBRICANT

To ease removal of existing exhaust components (especially on older vehicles) spray penetrating lubricant on all fasteners and hangers/insulators that will be loosened or removed and let soak before disassembly.

HARDWARE KIT:

- 1.[2] 3.00" Band Clamp

MINIMUM REQUIRED TOOLS:



15mm



Saw (or Other Cutting Tool)



Hanger Tool (Or Pry Bar)

MAGNAFLOW RECOMMENDS PROFESSIONAL INSTALLATION ON ALL THEIR PRODUCTS



WARNING: When working on, under, or around any vehicle exercise caution. Please allow the vehicle's exhaust system to cool before removal, as exhaust system temperatures may cause severe burns. If working without a lift always consult vehicle manual for correct lifting specifications. Always wear safety glasses and ensure a safe work area. Serious injury or death could occur if safety measures are not followed.

ATTENTION: Always install any supplied band or V-band clamps to the proper torque specifications of 40-45 ft-lbs for band clamps and 70 in-lbs for V-band clamps. Over tightening will result in the clamp breaking and will NOT be warranted by MagnaFlow.

INSTALLATION INSTRUCTIONS



Step 1: Begin removal of the OE muffler by marking cut point to the rear of OE Muffler as shown in photo below. Then cut the OE Exhaust at that cut point.

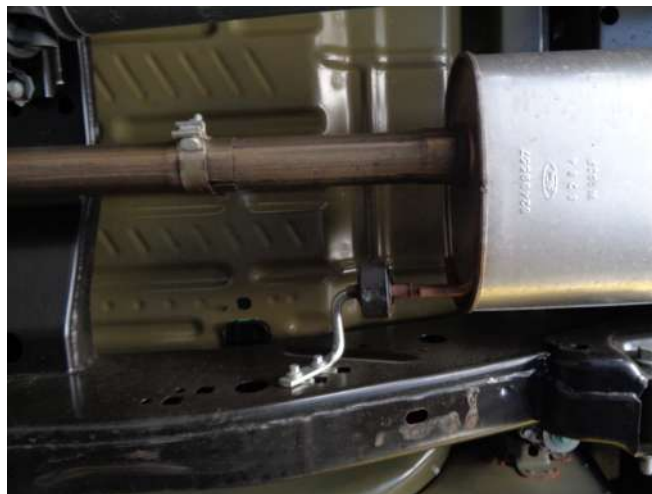

Step 2: Remove the OE exhaust by loosening and removing the bolts at the inlet flange. Then disengage the hangers from the rubber insulators. Be sure to not damage the rubber insulators as these will be used for the new MAGNAFLOW Muffler.



Step 3: Install new MagnaFlow Muffler by first selecting the Inlet Pipe for the model year of your vehicle. The smaller inlet diameter is for 2015 - 2020, the larger is for 2021. Loosely attach the inlet of the Inlet Pipe to the vehicles inlet pipe outlet using the OE clamp.



Step 4: Slip the Muffler Assembly inlet over the Inlet Pipe outlet, and the outlet to the cut muffler pipe. Loosely secure with the supplied clamps. Finish by inserting the welded hangers into the rubber insulators. Once a final position has been chosen for the new exhaust system, evenly tighten all clamps. Inspect after 25-50 miles for operation and re-tighten if necessary.