

2005-2010 Tacoma EC/CC 2.7/4.0L

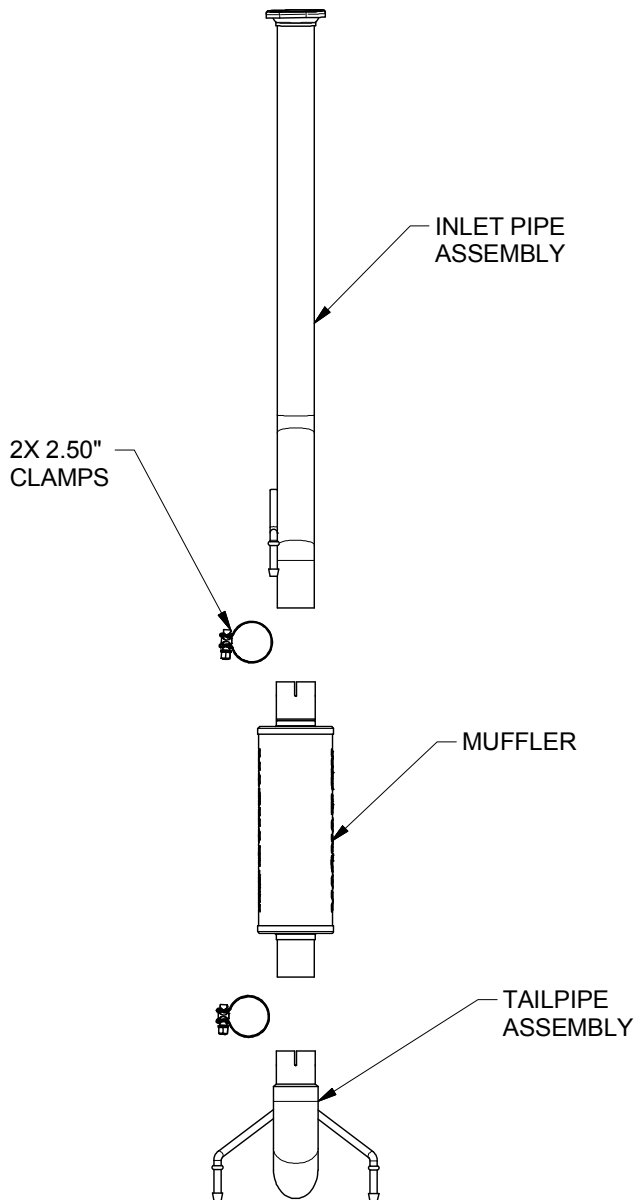

Warning: When working on, under, or around any vehicle exercise caution. Please allow the vehicle's exhaust system to cool before removal, as exhaust system temperatures may cause severe burns. If working without a lift, always consult vehicle manual for correct lifting specifications. Always wear safety glasses and ensure a safe work area. Serious injury or death could occur if safety measures are not followed.

1: (Carefully read all instructions before installation) Unbolt the (2) spring-loaded bolts fastening the OEM exhaust system to the catalytic converters. Do not discard the OEM fasteners as they will be reused to mount the new system. You can now disengage the welded hangers from the OEM rubber insulators and remove the system from the vehicle.

Step 2: Install the new Inlet Pipe Assembly by fitting the welded hanger into the rubber insulator, and by bolting it to the catalytic converters reusing the OEM fasteners. Leave all clamps and fasteners loose for final adjustment of the complete system. Fasten the Muffler to the inlet pipe using the supplied 2.50" clamp. Install the Tailpipe Assembly by fitting the welded hangers into the rubber insulators and by fastening it to the muffler using the supplied 2.50" clamp.

Step 3: With all components mounted loosely, adjust the system for overall aesthetics and clearance of frame & bodywork. (MAGNAFLOW recommends at least 1/2" of clearance between the exhaust system and any body panels to prevent heat-related body damage or fire.)

Step 4: Once a final position has been chosen for the new system, evenly tighten all fasteners from front to rear. The supplied band clamps must be VERY tight to properly align the pipes and prevent leaks (Approximately 65ft-lbs). Inspect all fasteners after 25-50 miles of operation and retighten if necessary.

**** Magnaflow Performance Exhaust recommends professional installation on all their products**