

GAS CAN RACK ACCESSORY

Hardware Kit Includes:

- (1) 4 – Button Head Socket Cap Bolts (8mm-1.25x25mm)
- (2) 4 – Lock washers (M8)
- (3) 8 – Flat Washers (M8)
- (4) 4 – Hex Head Nuts (8mm-1.25)

Components List:

- (1) 1 – Gas Can Rack (100020)
- (2) 1 – Holding Tube (100052)
- (3) 1 – Retainer Pin
- (4) 2 – Rubber Grommets

**LOOSE FIT ALL COMPONENTS.
DO NOT TIGHTEN UNTIL ALL
COMPONENTS ARE INSTALLED
AND ADJUSTED.**

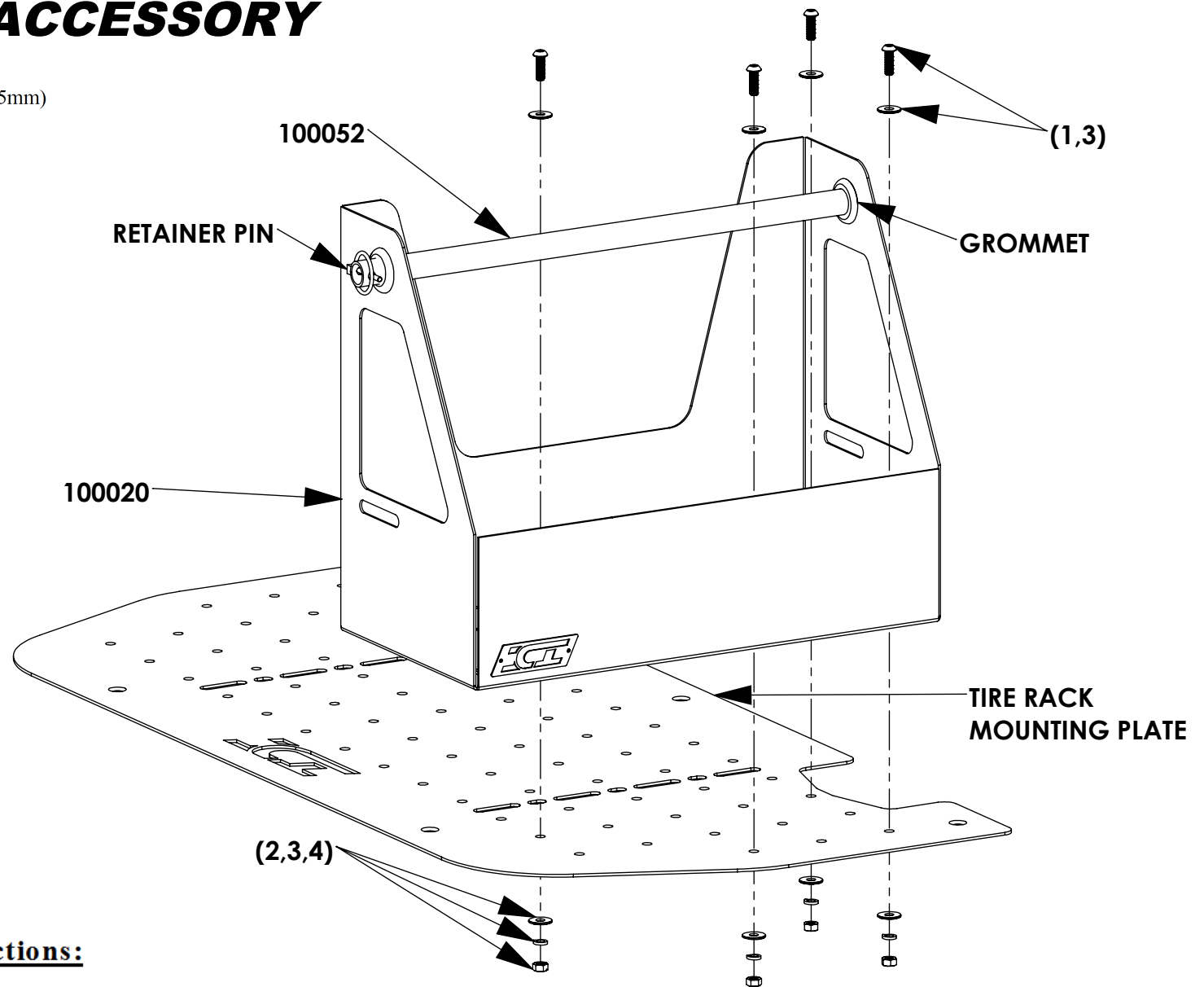

Step-By-Step Installation Instructions:

- (1) Begin by locating the mounting holes you will be using to mount the Gas Can Rack (100020) in the position of your choosing on the mounting plate or center tray of the tire rack. Make sure that the placement will not interfere with other components on the tire rack.
- (2) If you are mounting the Gas Can Rack to the mounting plate, remove the mounting plate from the tire rack. Attach the Gas Can Rack to the mounting plate using the holes that were located in step one using the provided hardware. Be sure not to cover the holes needed to mount the mounting plate back to the tire rack.
- (3) If you are mounting to the center tray of the tire rack, attach the Gas Can Rack to the tire rack using the provided hardware.
- (4) Insert the rubber grommets into the gas can rack so the holding tube can slide through them and prevent rattling. Use the retainer pin to secure the holding tube. If the gas jugs are loose in the rack, slots on cut into the side of the rack to add a strap to secure the jugs from unwanted movement.