

RECOVERY/RECYCLE/RECHARGE



Operating Instructions

WARNING!!

Do not stop the recovery process. Permanent damage will occur that could void the warranty.

CONTENTS

INTRODUCTION	4
SAFETY SUMMARY	4
SAFETY INFORMATION	4
ELECTRICAL SHOCK HAZARDS	4
MOTION HAZARDS	5
FUME HAZARDS	5
HEAT/FREEZING HAZARDS	5
EXPLOSION/FLAME HAZARDS	5
ADDITIONAL SAFETY INFORMATION	5
CERTIFICATION	6
ABOUT THIS MANUAL	6
ABOUT YOUR AIR CONDITIONING RECOVERY/RECYCLE SERVICE CENTER	6
WARRANTY	6
GENERAL INFORMATION	6
PRINCIPLES OF OPERATION	7
SETUP	7
THE MACHINE	8
BASIC COMPONENTS	8
CONTROLS AND CONTROL SYSTEM	9
FUNCTION SELECTOR KEYBOARD	9
ALARMS	9
PRELIMINARY OPERATIONS	10
AUTOMATIC PROCEDURE	10
ASSISTED PROCEDURE	13
RECOVERY AND RECYCLING	13
VACUUM	13
VACUUM LEAK TEST	13
ADDING NEW OIL	13
CHARGING THE A/C SYSTEM	14
LAST RECOVERED QUANTITY	15
ROUTINE MAINTENANCE	16
FILLING THE MACHINE TANK	16
VACUUM PUMP	17
Oil Fill	17
Checking Oil Level	17
Oil Change	17
REPLACING THE DRYER FILTERS	18
FILLING THE NEW OIL CONTAINER	18
EMPTYING THE USED OIL CONTAINER	19
CHECKING THE SCALE RESPONSE	19
PURGING NON-CONDENSABLE GASES	19
SETTINGS	19
LANGUAGE	19
UNITS OF MEASUREMENT	20
WEIGHT	21

PRESSURE	21
TEMPERATURE	21
DATA	21
PASSWORD PROTECTION	22
CUSTOMIZING THE DBA (DATABASE ADVANCED)	23
DATA ENTRY	23
USE	23
DELETION	23
DATABASE UPGRADE	24
CONVERSION CHART.....	24

INTRODUCTION

This machine is ETL Laboratories approved, in compliance with SAE J2788. We are dedicated to solving the issues surrounding the safe containment and proper management of refrigerants. Your new machine incorporates the latest technology and state of the art features to aid you in servicing R134a air conditioning and refrigeration systems.

NOTICE:

The SAE J2788 standard has, by design made recycling machines more complex than previous models that some End Users might be familiar with. Some noticeable changes that the End User should expect from ALL new recycling machines are the following.

1. **RECOVERY TIME:** The average recovery time is approximately 30 minutes. This time is necessary to meet the SAE J2788 standard which requires that the machine recovers at least 95% of the AC system refrigerant and cleans the refrigerant to a minimum of 95% purity.
2. **HOT WEATHER:** As the ambient temperature approaches 100°F, some End Users have experienced an increase in recovery time. This is due to the natural response of R134a when its temperature is elevated. R134a has difficulty transforming from a gas into a liquid state at elevated temperatures. The transformation into liquid is necessary for the machine to complete the recovery process. The End User might notice the same effect when performing a TANK CHARGING operation.
3. **COLD WEATHER:** As the ambient temperature approaches 50°F, some End Users have experienced an increase in recovery time. This is due to the natural response of R134a when its temperature is lowered. R134a has difficulty transforming from a liquid into a vapor state at reduced temperatures. The transformation into vapor is necessary for the machine to complete the distilling process. The End User might notice the same effect when performing a TANK CHARGING operation.

SAFETY SUMMARY

The following safety information is provided as guidelines to help you operate your new system under the safest possible conditions. Any equipment that uses chemicals can be potentially dangerous to use when safety or safe handling instructions are not known or not followed. The following safety instructions are to provide the user with the information necessary for safe use and operation. Please read and retain these instructions for the continued safe use of your service system.

SAFETY INFORMATION

Every craftsman respects the tools with which they work. They know that the tools represent years of constantly improved designs and developments. The true craftsman also knows that tools are dangerous if misused or abused. To reduce risk of discomfort, illness, or even death, read, understand, and follow the following safety instructions. In addition, make certain that anyone else that uses this equipment understands and follows these safety instructions as well.

READ ALL SAFETY INFORMATION CAREFULLY before attempting to install, operate, or service this equipment. Failure to comply with these instructions could result in personal injury and/or property damage.

RETAIN THE FOLLOWING SAFETY INFORMATION FOR FUTURE REFERENCE.

Published standards on safety are available and are listed at the end of this section under ADDITIONAL SAFETY INFORMATION.

The National Electrical Code, Occupational Safety and Health Act regulations, local industrial codes and local inspection requirements also provide a basis for equipment installation, use, and service.

The following safety alert symbols identify important safety messages in this manual.

When you see one of the symbols shown here, be alert to the possibility of personal injury and carefully read the message that follows.

Never fill the tank to more than 80% of maximum capacity as this will not leave an expansion chamber for absorbing any pressure increases.



ELECTRICAL SHOCK HAZARDS

- To reduce the risk of electric shock, unplug the power supply cord from the outlet before attempting any maintenance or cleaning. Turning off controls will not reduce this risk.
- Do not operate the machine with a damaged cord or plug — replace the cord or plug immediately. To reduce the risk of damage to electric plug and cord, disconnect the power cord by pulling on the plug rather than the cord.

An extension cord should not be used unless absolutely necessary. Use of an improper extension cord could result in a risk of fire, electric shock and component damage. If extension cord must be used, make sure:

- a. That pins on plug of extension cord are the same number, size, and shape as those on plug on recycler.
- b. That extension cord is properly wired and in good electrical condition; and
- c. That the wire size is large enough for the length of cord as specified below:

Length of cord in feet:	25	50	100	150
AWG size of cord:	16	12	10	8



MOTION HAZARDS

- Engine parts that are in motion and unexpected movement of a vehicle can injure or kill. When working near moving engine parts, wear snug fit clothing and keep hands and fingers away from moving parts. Keep hoses and tools clear of moving parts. Always stay clear of moving engine parts. Hoses and tools can be thrown through the air if not kept clear of moving engine parts.
- The unexpected movement of a vehicle can injure or kill. When working on vehicles always set the parking brake or block the wheels.



FUME HAZARDS

- FUMES, GASES, AND VAPORS CAN CAUSE DISCOMFORT, ILLNESS, AND DEATH! To reduce the risk of discomfort, illness, or death, read, understand, and follow the following safety instructions. In addition, make certain that anyone that uses the equipment understands and follows these safety instructions as well.
- Avoid breathing A/C refrigerant and lubricant vapor mist. Exposure may irritate eyes, nose, and throat. To remove R134a from the A/C system, use service equipment certified to meet the requirements of SAE J2788--R134a recycling equipment. Additional health and safety information may be obtained from refrigerant and lubricant manufacturers.
- Always perform vehicle service in a properly ventilated area. Never run an engine without proper ventilation for its exhaust.
- Stop the recycling process if you develop momentary eye, nose, or throat irritation as this indicates inadequate ventilation. Stop work and take necessary steps to improve ventilation in the work area.



HEAT/FREEZING HAZARDS

- When under pressure, refrigerants become liquid. When accidentally released from the liquid state they evaporate and become gaseous. As they evaporate, they can freeze tissue very rapidly. When these gases are breathed in, the lungs can be seriously damaged. If sufficient quantities are taken into the lungs, death can result. If you believe you have exposed your lungs to released refrigerant, seek immediate medical assistance.
- Refrigerants can cause frostbite and severe burns to exposed skin. Refrigerants are under pressure and can be forcibly sprayed in all directions if carelessly handled. Avoid contact with refrigerants and always wear protective gloves and make certain other exposed skin is properly covered.
- Refrigerants can also severely injure or cause permanent blindness to unprotected eyes. Refrigerants are under pressure and can be forcibly sprayed in all directions if carelessly handled. Avoid contact with refrigerants and always wear safety goggles.



EXPLOSION/FLAME HAZARDS

- Never recover anything other than the approved refrigerants as specified on the machine. Alternate refrigerants may contain flammables such as butane or propane and can explode or cause a fire. Recovering alternate refrigerants will also void the warranty on your machine.
- For general safety reasons, at the end of the working day or in between services (when services do not immediately follow), see to it that all valves on hoses and the machine are closed.

ADDITIONAL SAFETY INFORMATION

For additional information concerning safety, refer to the following standards.

ANSI Standard Z87.1 — SAFE PRACTICE FOR OCCUPATION AND EDUCATIONAL EYE AND FACE PROTECTION.

CAUTION: This equipment should be used in locations with mechanical ventilation that provides at least four air changes per hour or the equipment should be located at least 18 inches (457 mm) above the floor, or the equivalent.

CAUTION: Do not pressure test or leak test R134a service equipment and/or vehicle air conditioning systems with compressed air. Some

mixtures of air and R134a have been shown to be combustible at elevated pressures. These mixtures, if ignited, may cause injury or property damage. Additional health and safety information may be obtained from refrigerant manufacturers.

ATTENTION: Technicians using this equipment must be certified under EPA Section 609 (Environmental Protection Agency).

WARNING: There is the possibility of refrigerant contamination in the refrigerant container or the mobile A/C system being serviced or refrigerant container. Before recycling use proper equipment such as a refrigerant identifier, if necessary.

NOTE: Use only new refrigerant oil to replace the amount removed during the recycling process. Used oil should be discarded per applicable federal, state, and local requirements.

The manufacturer shall not be responsible for any additional costs associated with a product failure including, but not limited to, loss of work time, loss of refrigerant, cross contamination of refrigerant, and unauthorized shipping and/or labor charges.

IMPORTANT: R134a systems have special fittings (per SAE specifications) to avoid cross-contamination with R12 systems. DO NOT adapt your unit for a different refrigerant — system failure will result.

PERIODICALLY INSPECT AND MAINTAIN REFRIGERANT HOSES AND SEALS TO ENSURE THAT HOSES AND SEALS PREVENT THE ADDITION OF EXCESS AIR, DUE TO LEAKS, DURING THE RECOVERY PROCESS, WHICH WOULD INCREASE THE NCG LEVEL IN THE RECOVERED REFRIGERANT.

CERTIFICATION

All technicians opening the refrigeration circuit in automotive air conditioning systems must now be certified in refrigerant recovery and recycling procedures to be in compliance with Section 609 of the Clean Air Act Amendments of 1990.

ABOUT THIS MANUAL

This manual includes a SAFETY SUMMARY, MACHINE PREPARATION FOR USE, OPERATION procedures, and MAINTENANCE instructions, for your Air Conditioning Service Center. Anyone intending to use the machine should become familiar with ALL the information included in this manual (especially the SAFETY SUMMARY) before attempting to use it.

Before operating this machine for the first time, perform all PREPARATION FOR USE instructions. If your new machine is not properly prepared to perform a service, your service data could be erroneous. In order to properly perform a complete air conditioning service, follow all procedures in the order presented. Please take the time to study this manual before operating the machine. Then keep this manual close at hand for future reference. Please pay close attention to the SAFETY SUMMARY and all WARNINGS and CAUTIONS provided throughout this manual.

ABOUT YOUR AIR CONDITIONING RECOVERY/RECYCLE SERVICE CENTER

Your machine incorporates a highly accurate electronic scale for determining charging weights, etc. Other functions can also be performed with the electronic scale as you will discover during the operating procedures. Either standard or metric units of measure can be selected. Your new machine has been designed specifically to use R134a, to operate within the objectives of the Montreal Protocol.

WARRANTY

This product is warranted against any defect in materials and/or construction for a period of 1 (one) year from the date of delivery. The warranty consists of free-of-charge replacement or repair of defective component parts or parts considered defective by the Manufacturer. Reference to the machine serial number must be included in any requests for spare parts. This warranty does not cover defects arising from normal wear, incorrect or improper installation, or phenomena not inherent to normal use and operation of the product.

NOTE: Regarding the above, the Manufacturer reminds the Customer that according to international and national laws and regulations in force the goods are shipped at the sole risk of the latter and, unless otherwise specified in the confirmation of order phase, the goods are shipped uninsured. The Manufacturer therefore declines any and all responsibility in merit of CLAIMS for damages due to shipping, loading and unloading, and unpacking.

The product for which repair under guarantee is requested must be shipped to the manufacturer under the customer's exclusive responsibility and at the customer's exclusive expense and risk. In order to avoid damage during shipping for repairs, the Manufacturer's original packing must always be used and scale must be locked prior to shipping, refer to Setup on page 7.

The manufacturer declines any and all responsibility for damage to vehicles on which recovery/recycling and recharging are performed if said damage is the result of unskillful handling by the operator or of failure to observe the basic safety rules set forth in the instruction manual.

The warranty will expire automatically at the end of the 12 month period or whenever one of the following occurs: failure to perform maintenance; use of improper maintenance procedures; use of unsuitable lubricants and/or tracer fluids; inept or improper use; repairs performed by unauthorized personnel and/or with non-original spare parts; damage caused by shocks, fires, or other accidental events.

To activate the warranty, mail the attached warranty card.

GENERAL INFORMATION

Machine identification information is printed on the data plate on the rear of the machine (see Figure 1). Overall machine dimensions:

Height:	41.7 inch	Width:	19.7 inch	Depth:	20.5 inch	Weight:	200 lb
----------------	-----------	---------------	-----------	---------------	-----------	----------------	--------

Like any equipment with moving parts, the machine inevitably produces noise. The construction system, paneling, and special provisions adopted by

the Manufacturer are such that during work, the average noise level of the machine is less than 70 dB (A).

NOTE: The machine is intended for indoor use only.

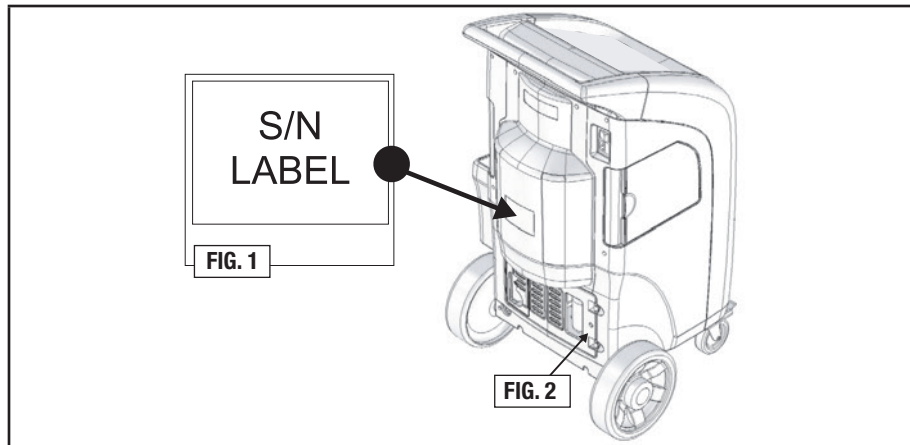

PRINCIPLES OF OPERATION

In a single series of operations, the machine permits recovering and recycling refrigerant with no risk of release into the environment, and also permits purging the A/C system of humidity and deposits contained in the oil. The machine is equipped with a built-in evaporator/separator that removes oil and other impurities from the refrigerant recovered from the A/C system and collects them in a container for that purpose. The fluid is then filtered, recycled and returned to the tank installed in the machine. The machine also permits running certain operational and leak tests on the A/C system.

SETUP

The machine is supplied fully assembled and tested. Referring to Figure 3, mount the hose with the BLUE quick-connect coupling on the male threaded connector indicated by the BLUE LOW PRESSURE symbol and the hose with the RED quick-connect coupling on the male threaded connector indicated by the RED HIGH PRESSURE symbol.

Referring to Figure 4, remove the protection under the refrigerant scale as follows (UNLOCK SCALE):

- Loosen the nut (Fig 4-2.)
- Loosen the screw (Fig. 4-1) two to four turns (do not remove from machine.)
- Tighten the nut (Fig. 4-2.)

NOTE: In the event that the equipment has to be transported; the refrigerant tank scale **MUST** be locked in place as follows:

- Use two 10mm wrenches.
- Loosen the nut (Fig. 4-2.)
- Switch the machine on.
- Tighten the screw slowly (Fig. 4-1) until the display signals ZERO Ref. Available.
- Tighten the nut (Fig. 4-2) forcefully (using the second wrench to lock the screw (Fig. 4-1).
- Check that the screw (Fig. 4-1) is actually locked, if necessary repeat the locking operation from the beginning.

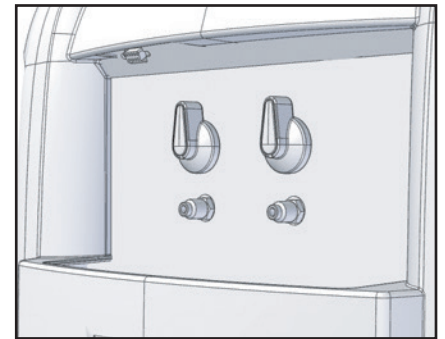

FIG. 3

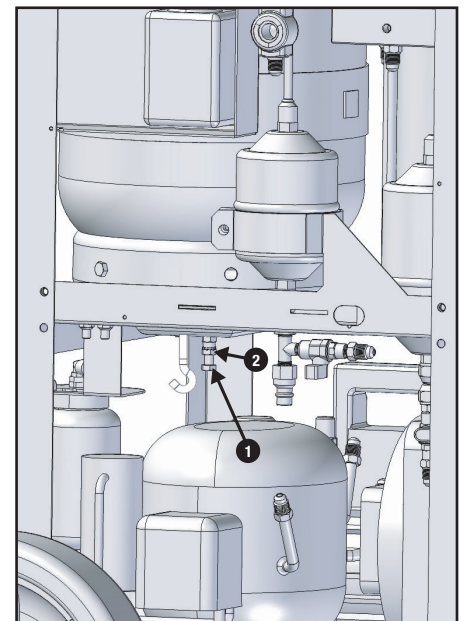

FIG. 4

THE MACHINE

BASIC COMPONENTS (Refer to Figures 5, 6, 7 and 8.)

A) Control Console	B) Service Valves	C) High & Low Service Ports	D) New Oil Bottle	E) Sight Glass	F) Serial Port
G) Vacuum Pump	H) Wheels	I) Main Switch	J) Socket for Electrical Supply Plug	K) Fuse Holder	L) Electronic Scale
M) Used Oil Bottle	N) Drier Filters	O) Tank	P) Tank Heater		

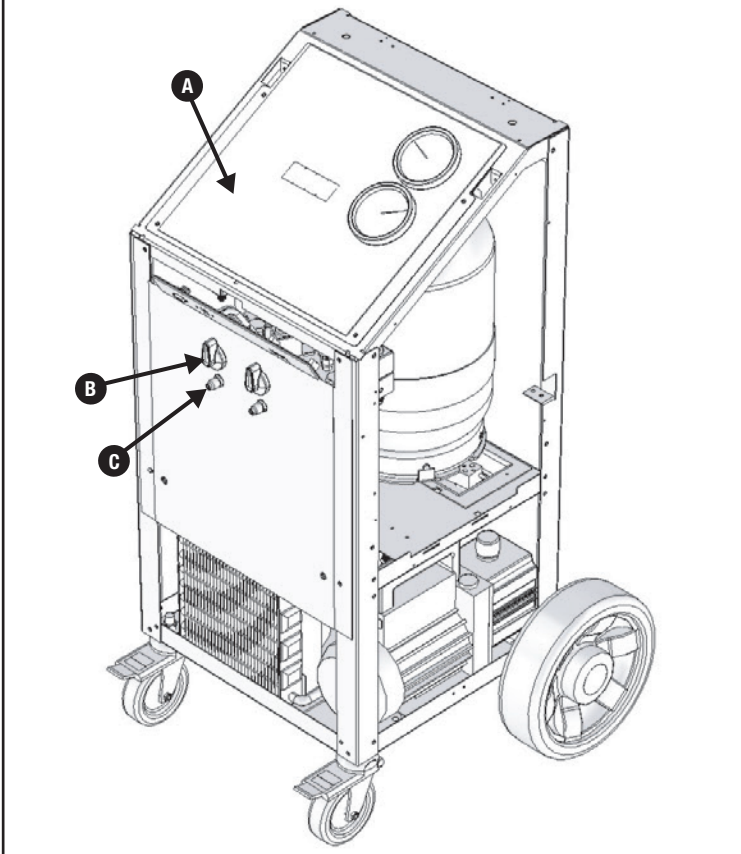

FIG. 5

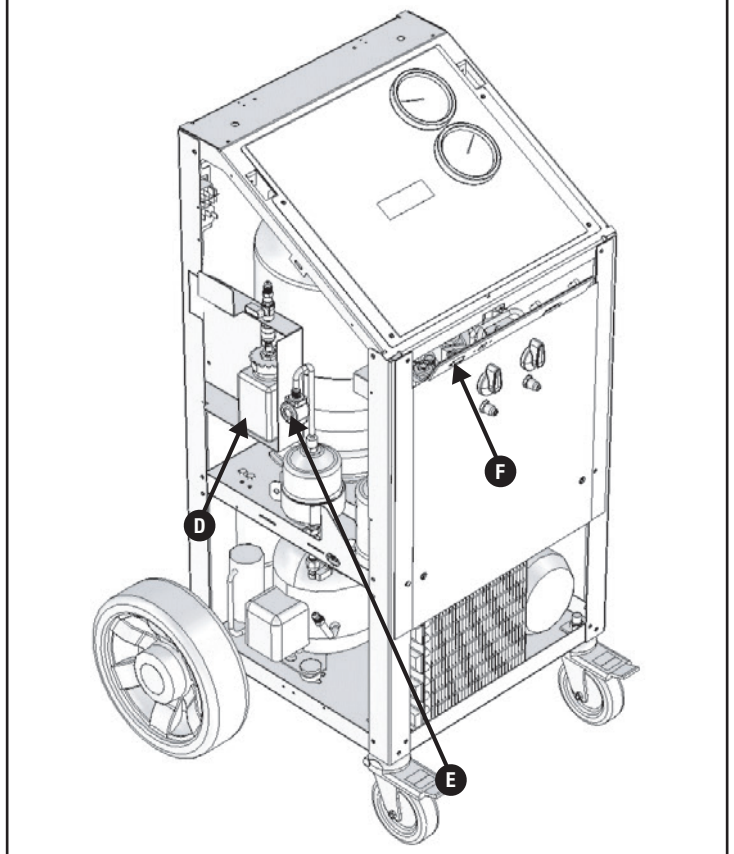

FIG. 6

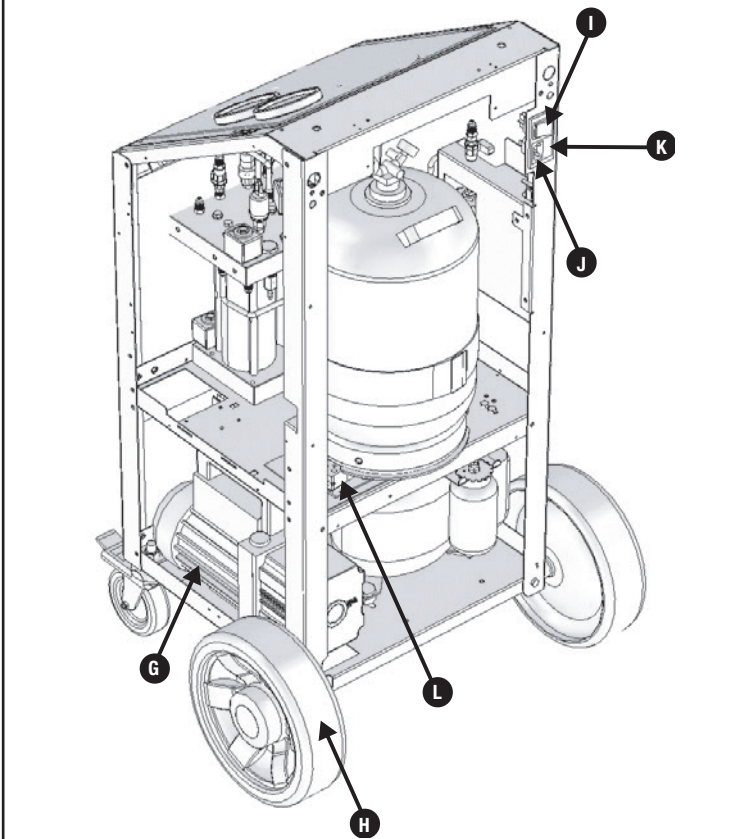

FIG. 7

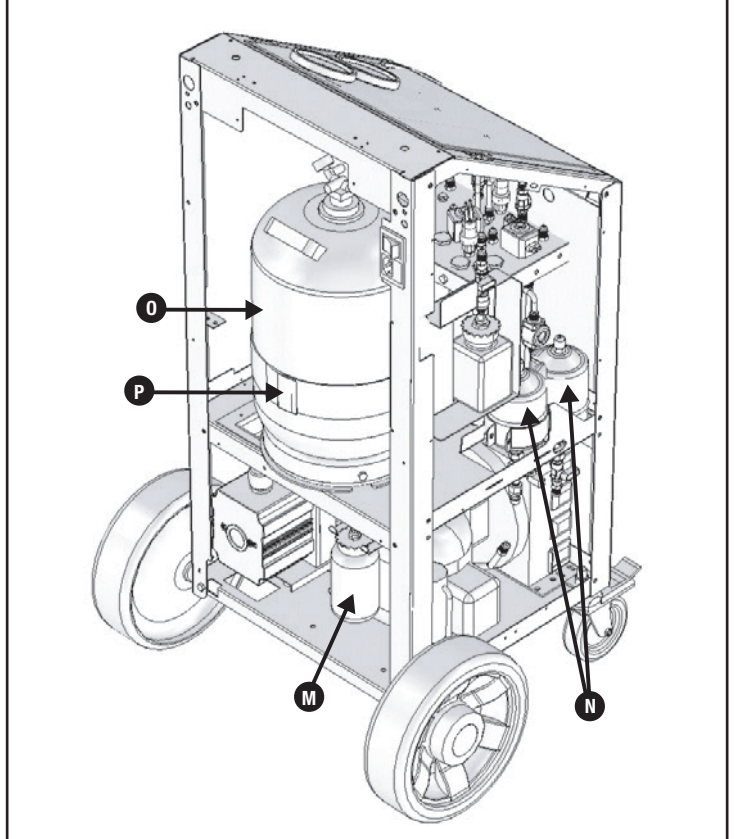

FIG. 8

CONTROLS AND CONTROL SYSTEM

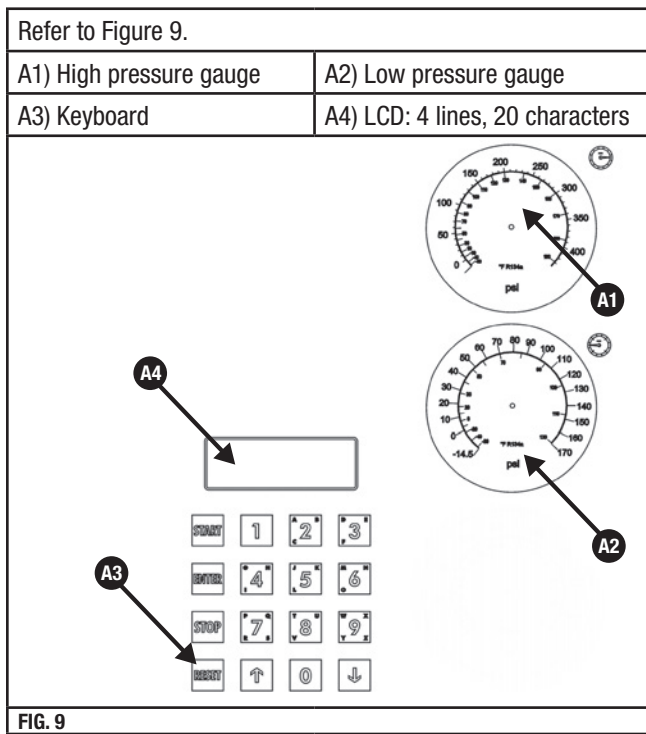

FIG. 9

FUNCTION SELECTOR KEYBOARD

STOP: Press to interrupt the operation being performed -- recovery - oil discharge - vacuum/oil charging - charging. Press START to resume operation from the point of interruption. Pressing STOP during an alarm state, error state, or end-of-operation state silences the audible alarm.

RESET: Press to interrupt the vacuum and the charging operation. The procedure will be restarted from the beginning.

ENTER: Press to confirm the procedure or operation flashing on the LCD.

↓: Press to move downward from one procedure or operation to another within a menu.

↑: Press to move upward from one procedure or operation to another within a menu.

START: Press to launch the procedure or operation shown on the display.

NOTE: "Tank" and "Bottle" are both used to describe a refrigerant container.

ALARMS

HIGH PRESSURE ALARM:

Beeper and LCD advise when the pressure of the fluid in the circuit reaches 290 psi (20 bar). The recovery operation is automatically interrupted. See page 19, Purging Non-Condensable Gases.

FULL TANK ALARM:

Beeper and LCD advises when the tank is filled to more than 80% of maximum capacity; that is, 24 lbs (10.8 kg.), the RECOVERY operation is automatically interrupted. To cancel this alarm, charge one or more A/C systems before recovering any more refrigerant or, using a scale and a D.O.T. tank, charge enough refrigerant into the D.O.T. tank so that the refrigerant available will be approximately 12 to 15 lbs. This refrigerant can be reclaimed later should 69788 need to be re-filled again with refrigerant. (See Empty Tank Alarm)

NOTE: Do not attempt to charge a new refrigerant tank (blue tank with a single port valve). These tanks are not D.O.T. approved for refilling and only have a check valve in them that allows refrigerant to leave the tank. Since these tanks have a check valve and DO NOT have pressure safety devices on them they cannot be refilled by 69788.

NOTE: Never transfer refrigerants to a cylinder or tank unless it is D.O.T. approved for refilling. D.O.T. approval is indicated by the designation "DOT 4BA" or "DOT 4BW" stamped on a tank's collar (handle.) If a refrigerant tank is overfilled, it may explode! Failure to abide by these warnings may cause personal injury or death.

EMPTY TANK ALARM:

Beeper and the LCD advise when the quantity of refrigerant fluid contained in the tank is too low. At this time it will be necessary to bottle fill 69788 to approximately 12 to 15 lbs of refrigerant in order for the alarm to clear.

SERVICE ALARM:

Service Alarm: The first service alarm; when the total recovered amount of refrigerant reaches 114 lbs, a beeper will sound and the LCD will display SERVICE ALARM. To clear the alarm, press STOP.

After the first alarm is cleared, filters should be purchased to have ready when 69788 requires that the filters be replaced. **The second service alarm;** when the total recovered amount of refrigerant reaches 132 lbs, a beeper will sound and the LCD will display ENTER FILTER CODE. There will also be 10 dots along the bottom

of the screen. To deactivate the alarm, the filters will need to be replaced (see page 18, Replacing the dryer filters.)

NOTE: It is good practice to change the Vacuum pump oil when the filters are being changed. (see page 17 & 18, Vacuum Pump)

LOW REFRIGERANT ALARM:

Beeper and the LCD advise when the charging quantity set exceeds the amount of refrigerant available. The minimum quantity of refrigerant is 4.50 lbs. If the gas available minus the charge quantity equals less than 4.5 lbs, 69788 will interrupt the attempt to charge and notify the operator that there is **low refrigerant**. At this time it will be necessary to tank charge 69788 to approximately 12 to 15 lbs of refrigerant in order to perform a charge. For instance, if the gas available is 9.50 lbs and the charge quantity is 1.80 lbs, then 9.50 lbs minus 1.80 lbs equals 7.70 lbs. 7.70 lbs is greater than 4.50 lbs so 69788 will perform the charge. If the gas available is 5.90 lbs and the charge quantity is 1.80 lbs, then 5.90 lbs minus 1.80 lbs equals 4.10 lbs. 4.10 lbs is less than 4.50 lbs, so 69788 will not charge and will let the operator know that there is insufficient refrigerant available.

PRELIMINARY OPERATIONS

Check that the main switch (Fig. 7-I, page 8) is set to 0. Check that all the machine valves are closed. Connect the machine to the electrical supply and switch on. Check that the vacuum pump oil level indicator shows at least one-half full. If the level is lower, add oil as explained in the ROUTINE MAINTENANCE section (page 16.) Check that in the new oil container (Fig. 6-D, page 8) there are at least 3.4 oz. (100 cc) of the oil recommended by the manufacturer of the vehicle A/C system. Check that the oil level in used oil container (Fig. 8-M, page 8) is less than 6.7 oz. (200 cc.) Check the machine's display to be sure there is at least 9 lbs (4.08 kg) of refrigerant in the tank. Should this not be the case, fill the on-board machine tank from an external tank of appropriate refrigerant following the procedure described in the ROUTINE MAINTENANCE section (page 16.)

WARNING:

DO NOT STOP THE RECOVERY PROCESS. Stopping the recovery process will definitely cause damage to the Compressor and perhaps other components. It will also cause the machine to fill up with unprocessed liquid refrigerant which will disable the machine from further use. Damage due to STOPPING THE RECOVERY PROCESS could void the warranty.

AUTOMATIC PROCEDURE

In the automatic mode, the recovery and recycling, oil discharge, and vacuum operations are performed in a sequence automatically. New oil can only be added after the vacuum pump has stopped. The machine then goes on to automatic refrigerant charging when the start button is pressed. Connect the hoses to the A/C system with the quick-connect couplings, bearing in mind that BLUE must be connected to the low-pressure side and RED to high pressure. Open the quick-connect valves. If the A/C system is equipped with a single quick-connect coupling for high or low pressure, connect and open only the relative quick-connect coupling and hose.

NOTE: Should the automatic procedure be selected when the A/C system is empty, the machine will begin with the vacuum phase. When working with A/C systems with a single high-pressure (RED) coupling, set the charging quantity at about 3 oz. (100g) more than the required quantity, since it will be impossible to recover the residual refrigerant from the hoses after charging.

Check that the high and low service valves on 69788 front panel are closed. Start the vehicle engine and switch on the air conditioner (Only if vehicle's AC is operational. If AC is not operational do not perform this step). Allow both to run for about 5 to 10 minutes with the passenger compartment fan at full speed. Switch off the vehicle engine.

The machine is equipped with a 4-line LCD display, maximum 20 characters per line. On the menu press the down arrow until the selected line flashes; in this manual it is enclosed in quotation marks. Select the automatic procedure by pressing ENTER when "Automatic Procedure" flashes on the LCD.

```
<AUTOMATIC PROCEDURE>
ASSISTED PROCEDURE
NEXT MENU
Ref avail x:xx Lb
```

→ENTER→

```
<VACUUM      XX MIN>
CHARGING     x:xx Lb
```

Set the vacuum time by keying in the desired time. To accept the time value that is already there, press enter. The machine will automatically perform a 2 minute VACUUM LEAK TEST when the time value is 11 minutes or longer. The VACUUM LEAK TEST will start after 10 minutes of vacuuming. If a leak is detected the machine will notify the operator that a leak was detected and will not continue vacuuming. If no leak is detected, the machine will continue vacuuming for the time remaining.

```
<VACUUM      XX MIN>
CHARGING     x:xx Lb
```

→2→0→

```
<VACUUM      20 MIN>
CHARGING     x:xx Lb
```

After vacuum time has been confirmed, the "charging x: xx lb" message will flash. Set the quantity of refrigerant to be charged, using one of the two

following procedures:

1. Set the quantity of refrigerant required for the A/C system to be charged. Following are examples for each set of units.

Lb, the display will have 4 digits, two digits then a decimal point and then two digits. The cursor moves from the left to the right. If the desired charge is 1.75 lbs, then you will enter 0 1 7 5.

Oz, the display will have 3 digits. The cursor moves from the right to the left. If the desired charge is 36 oz's, then you will enter 0 3 6.

Gr, the display will have 5 digits. The cursor moves from the right to the left. If the desired charge is 980 grams, the you will enter 9 8 0.

Kg, the display will have 3 digits, two digits then a decimal and then one digit. The cursor moves from the right to the left. If the desired charge is 1.5 Kg's then you will enter 1 5.

Lb-oz, the display will have 4 digits, two digits then a colon and then two digits. The cursor moves from the left to the right. If the desired charge is 1 lb's 7 oz's then you will enter 0 1 0 7.

```
VACUUM      XX MIN
<CHARGING   XX:XX Lb>
```

0→1→0→7→ENTER→

```
Open high and low
valves, then press
START
```

NOTE: When working with A/C systems with a single high-pressure (RED) coupling, set the charging quantity 3 oz. (.19 lb or 85g) more than the required quantity, since in this case it will be impossible to recover the residual refrigerant from the hoses after charging.

NOTE: In most cases, the quantity of refrigerant being charged into the A/C system is given on a data plate inside the engine compartment of the vehicle. If you do not know the correct quantity, consult the relevant manuals.

2. This model is equipped with refrigerant capacities stored in its database. Press the ↓ key, the following will appear on the display:

```
<ALFA ROMEO>
AUDI
BMW
CHRYSLER/JEEP
```

Use the arrow keys (↓↑) to select the required vehicle brand and press ENTER to confirm. The display will now show the various models (for example, if the brand chosen was FORD):

```
<COUGAR>
ESCORT
ESCORT D
FIESTA
```

Use the arrow keys (↓↑) to select the model required and press ENTER to confirm. The following will appear on the display:

```
VACUUM      20 MIN
<FILLING    w:yz Lb>
```

where “w:yz” refers to the amount of refrigerant for the vehicle selected. The machine will be ready to enter the correct quantity of refrigerant. Confirm by pressing the ENTER key.

Open the high and low service valves on the machine and press the START key to begin the refrigerant recovery/recycling phase, which will be indicated on the LCD as “RECOVERY/RECYCLING.” During this phase, the LCD will display the quantity of refrigerant recovered. Upon completion of recovery, the machine will stop and automatically discharge the used oil from the A/C system if any was present during recovery. The oil discharge operation lasts 6 to 14 minutes depending on the ambient temperature and the amount of refrigerant recovered. During the oil discharge operation the following screen will be displayed.

```
RECOVERY PAUSED
OIL DRAINING
PLEASE WAIT
TIME: 6 MIN
```

If any residual refrigerant is left in the A/C system, as indicated by an increase in pressure during the oil discharge phase, recovery will automatically restart.

NOTE: Stopping the recovery phase before the oil is discharged may damage the recovery/recycle machine's compressor.

Upon completion of discharge, the machine will check for the presence of air in the tank, and if it's necessary, purge the non condensable gases.

The alarm will sound continuously and the display will show:

```
AIR PURGE
Recovery ref   x:xx lb
Tp:   xx psi   T:xx °F
```

The Recovery/Recycle machine will automatically purge non-condensable gases (NCGS) if excess NCGS are detected at the end of recovery. Allow the unit to complete this procedure, eliminating the chance of NCGS being charged to the AC system.

The machine will automatically go on to running the vacuum phase for the preset time. Upon completion of the vacuum phase, the machine will stop, emit a beep, and display:

```
OIL INJECTION
Press start to continue
```

At this point, 69788 will pause and give the operator an opportunity to inject oil. If oil is needed, open the NEW oil valve and add the needed quantity. When completed, close the NEW oil valve and press START to go on to charging the quantity of refrigerant set previously. If no oil is to be injected, then press START.

NOTE: It's very important to remember to CLOSE the new oil valve before pressing the START button. Failure to close the valve will result in the refrigerant over pressurizing the NEW oil bottle and possibly causing the bottle to rupture.

NOTE: Using PAG oil or tracer in hybrid vehicles may damage the compressor. Use only suitable oil with a separate oil injection device.

NOTE: Charging may not run to completion due to pressure balance between the internal refrigerative storage tank and the A/C system. If this occurs, close the high pressure valve (leaving the low-pressure side open), start the vehicle and switch on the A/C system. The unit is equipped with a tank heater to limit this occurrence. When the charging operation is complete, the machine will display the following dialog boxes:

```
END OF CHARGE
CLOSE HIGH AND LOW
VALUES ON MACHINE
START: TO CONTINUE
```

```
START ENGINE
TURN ON A/C SYSTEM

START: TO CONTINUE
```

```
CHECK HIGH AND LOW
A/C SYSTEM PRESSURES

START: TO CONTINUE
```

```
CLOSE HIGH PRESSURE
COUPLER

START: TO CONTINUE
```

```
OPEN HIGH AND LOW
VALUES ON MACHINE
TURN ON A/C SYSTEM
START: TO CONTINUE
```

```
ALLOW HIGH AND LOW
PRESSURE TO EQUALIZE
CLOSE ALL VALVES
RESET: WHEN COMPLETE
```

ASSISTED PROCEDURE

WARNING:

DO NOT STOP THE RECOVERY PROCESS. Stopping the recovery process will definitely cause damage to the Compressor and perhaps other components. It will also cause the machine to fill up with unprocessed liquid refrigerant which will disable the machine from further use. Damage due to STOPPING THE RECOVERY PROCESS could void the warranty.

RECOVERY AND RECYCLING

Connect the hoses to the A/C system with the quick-connect couplings, bearing in mind that BLUE must be connected to the low-pressure side and RED to high pressure. If the A/C system is equipped with a single quick-connect coupling for high or low pressure, connect only the relative coupling and hose. Check that the high and low pressure valves are closed. Start the vehicle engine and the air conditioner and allow both to run for 5 to 10 minutes with the passenger compartment fan at full speed. Only perform this step if the vehicle's AC is operational. Switch off the vehicle engine. Select the assisted procedure by pressing ENTER when "Assisted Procedure" flashes on the LCD. Select recovery and recycling by pressing ENTER when "Recovery/Recycling" flashes on the LCD.

Open the high and low service valves on the machine and press the START key to begin the refrigerant recovery/recycling phase, which will be indicated on the LCD as "RECOVERY/RECYCLING ." During this phase, the LCD will display the quantity of refrigerant recovered. Upon completion of recovery, the machine will stop and automatically discharge the used oil from the A/C system if any was present during recovery. The oil discharge operation lasts 6 to 14 minutes depending on the ambient temperature and the amount of refrigerant recovered. During the oil discharge operation the following screen will be displayed.

```
RECOVERY PAUSED
OIL DRAINING
PLEASE WAIT
TIME: 6 MIN
```

If any residual refrigerant is left in the A/C system, as indicated by an increase in pressure during the oil discharge phase, recovery will automatically restart.

Upon completion of discharge, the machine will check for the presence of air in the tank, and if it's necessary, purge the non condensable gases. The alarm will sound continuously and the display will show:

```
AIR PURGE
Recovery ref  x:  xx  lb
Tp:  xx  psi   T:  xx  °F
```

The recovery/recycle machine will automatically purge non-condensable gases (NCGS) if excess NCGS are detected at the end of recovery. Allow the unit to complete this procedure to reduce the risk of comebacks that can be caused by charging excess NCGS into an A/C system.

VACUUM

Use the quick-connect couplings to connect the hoses to the A/C system, bearing in mind that BLUE must be connected to the low pressure side and RED to high pressure. If the system is equipped with a single quick-connect coupling for high or low pressure, connect only the relative hose. Select the assisted procedure by pressing ENTER when "Assisted Procedure" flashes on the LCD. Select the vacuum operation, when the message "Vacuum xx min." flashes on the LCD. Set the vacuum time only if different from that previously used. Press ENTER to confirm. Open the high and low pressure valves of the machine and press START.

VACUUM LEAK TEST

The machine will automatically perform a 2 minute VACUUM LEAK TEST when the time value is 11 minutes or longer. The VACUUM LEAK TEST will start after 10 minutes of vacuuming. If a leak is detected the machine will notify the operator that a leak was detected and it will not continue vacuuming. If no leak is detected, the machine will continue vacuuming for the time remaining.

ADDING NEW OIL (Fig. 10)

Measure the quantity of oil extracted from the A/C system and check that the new oil container contains at least .67 oz (20 cc.) With the A/C system in vacuum, open the high and low pressure valves of the machine (if the A/C system is equipped with a single quick-connect coupling for high or low pressure, open only the relative valve). Open the oil valve until the quantity equal to the quantity of oil previously extracted is transferred. Close the oil valve when reaching the desired oil level.

ATTENTION: Since the oil in the container will decrease in level, the quantity must be calculated by difference. Upon completion of the oil injection phase, you may go on to refrigerant fluid charging.

NOTE: Using PAG oil or tracer in hybrid vehicles may damage the compressor. Use only suitable oil with a separate oil injection device.

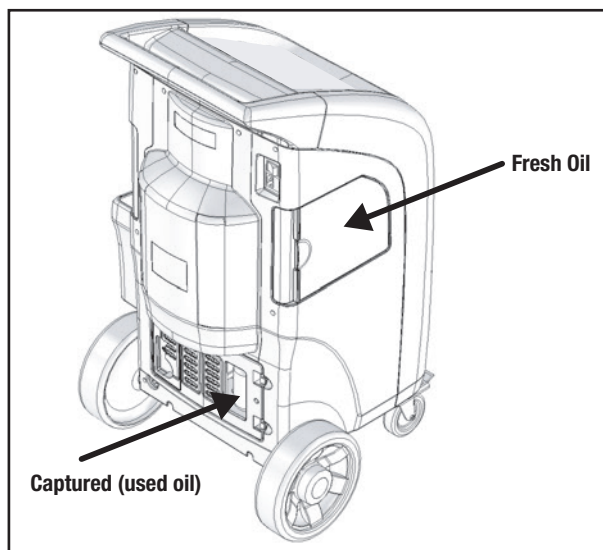

FIG. 10

CHARGING THE A/C SYSTEM

Press the UP or DOWN arrow to select the ASSISTED PROCEDURE and then press ENTER when the “Assisted Procedure” message flashes on the LCD. Press the down arrow to select REF CHARGING. When “REF CHARGING XX:XX lb” flashes on the LCD:

Set the quantity of refrigerant required for the A/C system to be charged using one of the two procedures below.

1. Manual Operation: Set the quantity for the charge. Following are examples for each set of units.

Lb, the display will have 4 digits, two digits then a decimal point and then two digits. The cursor moves from the left to the right. If the desired charge is 1.75 lbs, then you will enter 0 1 7 5.

Oz, the display will have 3 digits. The cursor moves from the right to the left. If the desired charge is 36 oz’s, then you will enter 0 3 6.

Gr, the display will have 5 digits. The cursor moves from the right to the left. If the desired charge is 980 grams, the you will enter 9 8 0.

Kg, the display will have 3 digits, two digits then a decimal and then one digit. The cursor moves from the right to the left. If the desired charge is 1.5 Kg’s then you will enter 1 5.

Lb-oz, the display will have 4 digits, two digits then a colon and then two digits. The cursor moves from the left to the right. If the desired charge is 1 lb’s 7 oz’s then you will enter 0 1 0 7.

NOTE: When working with A/C systems with a single high-pressure (RED) coupling, set the charging quantity 3 oz. (.19 lb or 85 g) more than the required quantity, since in this case it will be impossible to recover the residual refrigerant from the hoses after charging.

2. This model is equipped with some refrigerant capacities stored in its database. Press the ↓ key; the following will appear on the display:

```

<ALFA ROMEO>
AUDI
BMW
CHRYSLER/JEEP
  
```

Use the arrow keys (↓↑) to select the required vehicle brand and press ENTER to confirm. The display will now show the various models (for example, if the brand chosen was FORD):

```

<COUGAR>
ESCORT
ESCORT D
FIESTA
  
```

Use the arrow keys (↓↑) to move to the model required and press ENTER to confirm. The following will appear on the display:

```

VACUUM      20 MIN
<FILLING   w:yz lb>
  
```

Where “w:yz” refers to the quantity for the vehicle selected. The machine will be ready to enter the correct quantity of refrigerant. Confirm by pressing the ENTER key.

Open the high and low service valves on the machine and press the START key (in the case of an A/C system with a single high or low pressure coupling, open only the relative valve on the machine).

NOTE: Charging may not run to completion due to pressure balance between the internal tank and the A/C system. If this occurs, close the valve on the high pressure quick connect coupling (leaving the low-pressure side open), turn on the vehicle and switch on the A/C system. The unit is equipped with a tank heater to limit this occurrence. When the charging operation is complete, the machine will display the following dialog boxes:

**END OF CHARGE
CLOSE HIGH AND LOW
VALVES ON MACHINE
START: TO CONTINUE**

**START ENGINE
TURN ON A/C SYSTEM
START: TO CONTINUE**

**CHECK HIGH AND LOW
A/C SYSTEM PRESSURES
START: TO CONTINUE**

**CLOSE HIGH PRESSURE
COUPLER
START: TO CONTINUE**

**OPEN HIGH AND LOW
VALVES ON MACHINE
TURN ON A/C SYSTEM
START: TO CONTINUE**

**ALLOW HIGH AND LOW
PRESSURE TO EQUALIZE
CLOSE ALL VALVES
RESET: WHEN COMPLETE**

LAST RECOVERED QUANTITY

To see how much refrigerant was recovered during the last recovery phase.

**AUTOMATIC PROCEDURE
ASSISTED PROCEDURE
<NEXT MENU>
Ref avail x,xx lb**

Select NEXT MENU:

**<LAST RECOVERED QTY>
TANK CHARGING
AIR PURGE
DATA AND CONFIGURAT.**

Select LAST RECOVERED QTY:

**LAST RECOVERED QTY
XX.XX LB
STOP: MAIN MENU**

This valve gets updated after each complete recovery phase.

ROUTINE MAINTENANCE

FILLING THE MACHINE TANK

This operation must be performed whenever the available refrigerant fluid in the tank is less than 9 lbs (4.8 kg) and must be performed when the "Empty Tank" alarm is displayed. Recommended capacity is between 10 and 15 lbs. Obtain a tank of R134a. Connect the tank adapter fitting (69788-332) to the R134a tank. Then, connect the high pressure hose from the tank to the high pressure valve on the machine. Open both the valve on the external tank and the high pressure valve on the machine. If the external tank is not supplied with a liquid valve, turn it upside down to obtain a higher delivery rate.

Switch the machine on. The MAIN MENU will appear after a few seconds:

```
AUTOMATIC PROCEDURE
ASSISTED PROCEDURE
<NEXT MENU>
Ref avail  X,XX Lb
```

Select NEXT MENU:

```
LAST RECOVERED QTY
<TANK CHARGING>
AIR PURGE
DATA AND CONFIGURAT.
```

Select TANK CHARGING:

```
TANK CHARGING
Set amount    xx lb
Min: x      Max: xx lb
PRESS: START
```

Set the quantity of refrigerant and press START to confirm:

Follow the instructions on the screen.

```
Use the HP hose to
connect external
tank and
PRESS: START
```

Press START again:

Follow the instructions on the screen.

```
Open the external
tank valve, open
HP valve and
PRESS: START
```

Press START again:

```
TANK CHARGING
0 LB
ACP xx PSI
TP  xx PSI
```

The machine will now fill the machine tank with the preset quantity $\pm 1.1\text{lb}$ ($\approx 500\text{g}$). When the quantity minus 1.1lb ($\approx 500\text{g}$) is reached, the machine will stop and display:

```
TANK CHARGING
Close the external
tank and
PRESS START
```

Close the tank valve and press START. The machine will stop automatically after having recovered the residual refrigerant from the hoses. Close the high pressure valve. Disconnect the external tank.

VACUUM PUMP

Perform the operations listed below on a routine basis in order to ensure the best operation of the vacuum pump:
When filling or replacing the pump oil, use only the oil recommended by the manufacturer.

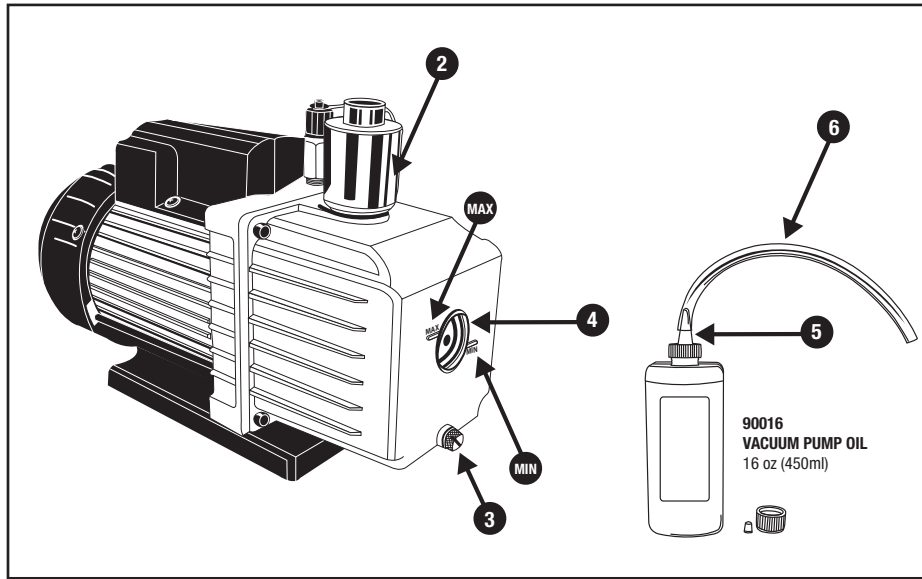

FIG. 11

OIL FILL - (NEW MACHINE)

This vacuum pump has been tested at the factory and shipped with only trace amounts of oil. OIL MUST BE ADDED BEFORE OPERATING! Failure to add oil will damage the cartridge and void warranty.

NOTE: Make sure the oil drain valve located below the front casing is closed before attempting to add oil (Fig 11-3.)

- 1) Disconnect the machine from the electrical supply.
- 2) Remove the rear cover (6 screws.)
- 3) Unscrew the oil fill/muffler plug (Fig 11.2.)
- 4) Oil Bottle: A) Remove oil bottle cap
B) Remove the silver foil
C) Attach the filling top (be sure to remove the red cap) (Fig. 11-5.)
D) Attach the filling hose (Fig. 11-6.)
- 5.) Slowly add oil until oil level rises to the top of the oil level line. Do not overfill with oil! (Fig 11-4.)
- 6.) Replace the oil fill/muffler plug (Fig 11.2.)
- 7.) Re-install the rear cover (6 screws.)

CHECKING OIL LEVEL

The oil level in the sight glass should be between the max and min line (Fig 11-4.) If oil level falls below the MIN line add oil per oil fill instructions.

OIL CHANGE

The vacuum pump oil must be replaced:

- 1) Every 120 working hours, or
- 2) When the filter/dryers are replaced, or
- 3) At the beginning or end of every season, or
- 4) Whenever the oil changes color due to absorption of moisture.

Before beginning the oil change procedure, obtain an empty 16 oz. (1 pint) or larger container in which to collect the used oil.

- 1) Disconnect the machine from the electrical supply.
- 2) Remove the rear cover (6 screws.)
- 3) Unscrew the oil fill/muffler plug (Fig 11.2.)
- 4) Unscrew the drain plug (Fig. 11.3.)
- 5) Allow all the oil to run out into a disposal container (drain clearance is less than 3.95 inches.)
- 6) Close the drain plug (Fig. 11-3.)
- 7) Pour in new oil through the fill hole until the level rises to the midpoint on the indicators (Fig. 11-4.)
- 8) Replace the oil fill/muffler plug (Fig. 11-2.)

9) Replace the rear plastic cover on the machine (6 screws.)

NOTE: When changing the vacuum pump oil, dispose of used oil as per federal, local and state regulations.

REPLACING THE DRYER FILTERS

Replace the filters when the machine alerts you. Replace the filters only with Mastercool part numbers: 69788-FLTRPK. When changing the filters you will need a filter code.

LOCK OUT: If you are changing the filters because of the Second Service alarm (see page 9) and has locked out 69788, then a filter code will be needed to re-set 69788. Before changing the filters, call Mastercool Inc.

NO LOCK OUT: If the filters are being changed at an unscheduled time, no filter code will be needed to continue operating 69788. Only when the machine reaches the pre-programmed recovery quantity of 132 lbs will it lock out. Once the machine is locked out, the filter code will be needed to re-set the 69788. (See LOCK OUT)

To change the filters, proceed as described below (refer to Fig. 12):

- 1) Disconnect the machine from the electrical supply.
- 2) Wear protective gloves and glasses.
- 3) Remove the rear plastic cover from the machine (6 screws.)
- 4) Close both of the valves on top of tank.
- 5) Close the valve (Fig. 12-1) under the filter (Fig. 12-4.)
- 6) Connect the low pressure quick-connect coupling to the male connector (Fig. 12-2) under the filter (Fig. 12-4.)
- 7) Connect the machine to the electrical supply and turn the machine on.
- 8) Put in the filter code. (Only if locked out) To put in the filter code, you will need to use the down arrow key to move the cursor to the next character. To input a letter, continue to press the same number with the corresponding letter until the desired letter appears. Once the entire code is showing on the screen, press the ENTER key.
- 9) Using Assisted Procedure, start a recovery operation (**NOTE:** the valve under the low pressure filter [Fig. 12-3] should be open).
- 10) When oil draining is reached, immediately close the valve (Fig. 12-3) under the filter (Fig. 12-5) and turn the machine off.
- 11) Disconnect the machine from the electrical supply.
- 12) Disconnect the low pressure quick-connect coupling from the connector (Fig. 12-2) under the filter (Fig. 12-4).
- 13) Replace the filters. **IMPORTANT:** The filter replacement must be performed as quickly as possible in order to avoid possible contamination by moisture in the ambient air.
- 14) Open the valve (Fig. 12-1) under the filter (Fig. 12-4) and the valve (Fig. 12-3) under the filter (Fig. 12-5).
- 15) Open both valves on top of the tank.
- 16) Connect the machine to the electrical supply and turn the machine on. (Leave the rear cover off at this time)
- 17) Press start when the machine displays "RECOVERY PROCEDURE INTERRUPTED, START: TO CONTINUE."
- 18) Press reset when the machine displays "ERROR SYSTEM EMPTY."
- 19) Tank charge about 1 lb (-500g) of refrigerant to charge the machine circuit.
- 20) While the machine is recovering, use an electronic leak detector to check the seal on the connections that were opened to replace the filters. Retighten if necessary.
- 21) Turn the machine off and replace the rear plastic cover on the machine. (6 screws)
- 22) The machine is now ready for normal use.

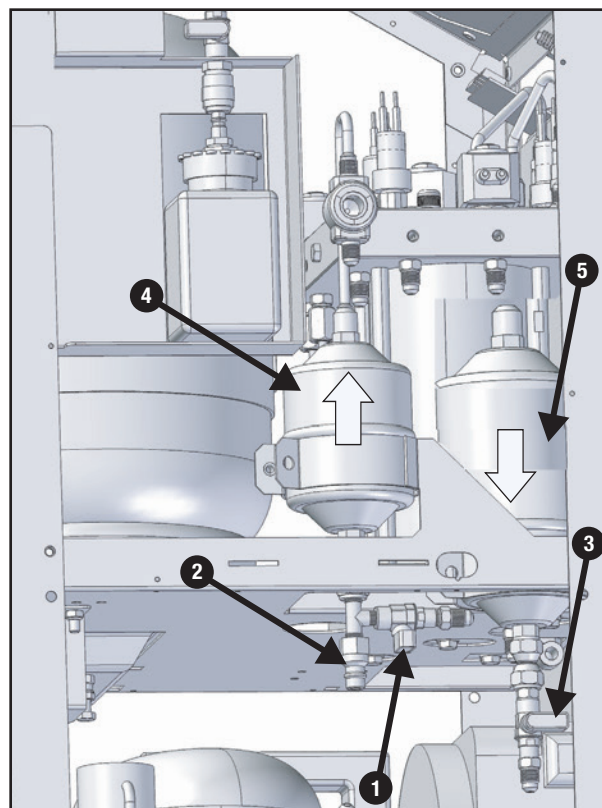

FIG. 12

FILLING THE NEW OIL CONTAINER

It is good practice to fill the oil container whenever the oil level falls below 3.4 oz (100 cc) in order to guarantee that there will be sufficient oil for topping off during successive operations. Always refer to the information provided by the A/C system manufacturer for oil specifications (oil is not supplied.)

Lift the quick-connect coupling near the top of the container and remove the container complete with cap. Unscrew the cap and fill the container with the correct quantity of oil of suitable type and grade. Screw the cap back on and, lifting the quick-connect coupling as above, replace the container in its holder.

EMPTYING THE USED OIL CONTAINER

This operation must be performed whenever the oil level exceeds 6.7 oz (200 cc.)

Procedure: Remove the container from its holder. Unscrew the container while holding the cap in place. Empty the used oil into a suitable container for used oils. Screw the container back in place while holding the cap in place. Carefully replace the container into its holder. (Dispose of used oil

as per your federal, local and state regulations.)

CHECKING THE SCALE RESPONSE

Turn the unit on and note the “REF AVAILABLE” reading. Hang the 500g test weight that was supplied with the machine from the hook under the scale. (Fig 13-7) The “REF AVAILABLE” should go up by 500g+/-28g, 1.10lb +/-0.06lb or 18oz +/-1oz depending on what units the machine is set at. If the results of the test are not within these specifications, it is recommended that the scale be re-calibrated. The scale re-calibration should be done by a qualified Service Technician. The equipment necessary for scale re-calibration is not supplied with 69788.

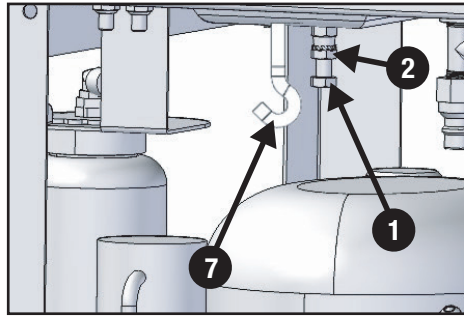

FIG. 13

PURGING NON-CONDENSABLE GASES

If 69788 should become loaded with excessive tank pressure due to the accumulation of NCG (Non-Condensable Gases) it will be necessary that the operator purge the NCG manually. The operator will need to start the manual purge and the machine will automatically stop the purge when the proper pressure is reached. The operator can also stop the purge manually before the machine determines the proper pressure.

Select NEXT MENU, scroll down with the arrow, select AIR PURGE. The following screen will be displayed:

```
AIR PURGE
TANK PRESS    XX PSI
TANK TEMP     XX.X F
PRESS: START
```

Press RESET to exit the manual purge.

NOTE: During the purging process some refrigerant will be released from the tank. Some loss of refrigerant is normal and unavoidable due to design limitations and the nature of R134a refrigerant.

SETTINGS

LANGUAGE

Switch the machine on. The MAIN MENU will appear after a few seconds:

```
AUTOMATIC PROCEDURE
ASSISTED PROCEDURE
<NEXT MENU>
Ref avail x,xx lb
```

Select NEXT MENU, Press ENTER:

```
LAST RECOVERED QTY
TANK CHARGING
AIR PURGE
<DATA AND CONFIGURAT.>
```

Select DATA AND CONFIGURAT., Press ENTER:

```
DATA
<CONFIGURATION>
SERVICES
PREVIOUS MENU
```

Select CONFIGURATION:

```
<LANGUAGE>
MEASURE UNITS
PREVIOUS MENU
```

Select LANGUAGE:

```
ENGLISH  <-
ITALIANO
FRANCAIS
ESPANOL
```

NOTE: The current language is indicated by the symbol "<-".

Use the ARROW keys to scroll the available languages. Confirm a language by pressing ENTER. The machine will reset and a few seconds later the MAIN MENU will appear in the chosen language.

UNITS OF MEASUREMENT

Switch the machine on. The MAIN MENU will appear after a few seconds:

```
AUTOMATIC PROCEDURE
ASSISTED PROCEDURE
<NEXT MENU>
Ref avail  X,XX lb
```

Select NEXT MENU:

```
LAST RECOVERED QTY
TANK CHARGING
AIR PURGE
<DATA AND CONFIGURAT.>
```

Select DATA AND CONFIGURAT:

```
DATA
<CONFIGURATION>
SERVICES
PREVIOUS MENU
```

Select CONFIGURATION:

```
LANGUAGE
<MEASURE UNITS>
PREVIOUS MENU
```

Select MEASURE UNITS:

```
WEIGHT      (lb)
PRESSURE    psi
TEMPERATURE °F
EXIT
```

WEIGHT

Select WEIGHT:

```
WEIGHT      (lb)
PRESSURE    psi
TEMPERATURE °F
EXIT
```

Press ENTER to change from lb, oz, gr, Kg or lb:oz

```
WEIGHT      (lb)
PRESSURE    psi
TEMPERATURE °F
EXIT
```

Select another parameter or EXIT to go to the previous screen.

PRESSURE

Select PRESSURE:

```
WEIGHT      (lb)
PRESSURE    psi
TEMPERATURE °F
EXIT
```

Press ENTER to change from bar to psi or from psi to bar.

```
WEIGHT      (lb)
PRESSURE    psi
TEMPERATURE °F
EXIT
```

Select another parameter or EXIT to go to the previous screen.

TEMPERATURE

Select TEMPERATURE:

```
WEIGHT      (lb)
PRESSURE    psi
TEMPERATURE °F
EXIT
```

Press ENTER to change from °C to °F or from °F to °C.

```
WEIGHT      (lb)
PRESSURE    psi
TEMPERATURE °F
EXIT
```

Select another parameter or EXIT to go to the previous screen.

DATA

This menu shows all the data read by the machine.

Switch the machine on. The MAIN MENU will appear after a few seconds:

```
AUTOMATIC PROCEDURE
ASSISTED PROCEDURE
<NEXT MENU>
Ref avail X.XX lb
```

Select NEXT MENU:

```
LAST RECOVERED QTY
TANK CHARGING
AIR PURGE
<DATA AND CONFIGURAT.>
```

Select DATA AND CONFIGURAT.:

```
<DATA>
CONFIGURATION
SERVICES
PREVIOUS MENU
```

Select DATA.

The following screen will be displayed:

```
Ref avail      XX.XX lb
Tank temper    XX.X F
Tank Press     XX psi
ACp            xx psi
```

NOTE: TP: xx psi will be flashing

- Ref avail.: quantity of refrigerant available in the storage tank.
- Tank temp.: temperature of the refrigerant storage tank.
- Tp: pressure of refrigerant tank.
- ACp: pressure in the external air conditioning system.

PASSWORD PROTECTION

A password can be used to prevent the machine from being used. Once a password is activated, it will be needed every time the operator makes an attempt to activate any command from the MAIN screen. To use the password feature,

```
AUTOMATIC PROCEDURE
ASSISTED PROCEDURE
<NEXT MENU>
Ref avail  X,XX lb
```

Select NEXT MENU:

```
LAST RECOVERED QTY
TANK CHARGING
AIR PURGE
<DATA AND CONFIGURAT.>
```

Select DATA AND CONFIGURAT.:

```
DATA
CONFIGURATION
<SERVICES>
PREVIOUS MENU
```

Select SERVICES:

```
<PASSWORD>
COUNTERS
```

Select PASSWORD:

```
....
```

Put in your own 4 digit password and press enter.

CUSTOMIZING THE DBA (DATABASE ADVANCED)

Select ASSISTED PROCEDURE. Scroll down with the (↓) DOWN arrow key until the vehicle brands in the DBA appear:

```

<ALFA ROMEO>
AUDI
BMW
CHRYSLER/JEEP

```

Press the (↑) UP arrow key:

```

TOYOTA
VOLKSWAGEN
VOLVO
<USER DEFINED>

```

Select the USER DEFINED option:

```

<ABCD EFGH>
HIJK MNOP
          ????
          ????

```

DATA ENTRY

To enter customized data, press START. The following screen will be displayed:

```

MODEL NAME :
.....
MODEL QUANTITY :
XXXX

```

Type in the vehicle model on the keyboard; press ENTER to confirm.

Use the down arrow key to move the cursor to the next character.

Type in the corresponding refrigerant quantity; press ENTER to confirm.

NOTE: Refrigerant quantity is in grams.

USE

To use the customized data, scroll with the (↑↓) arrow keys to the desired vehicle model; press ENTER to confirm.

DELETION

To delete custom data fields, scroll with the (↑↓) arrow keys to the desired vehicle model and press “0” (ZERO). An alarm signal will sound and the following screen will be displayed.

```

VEHICLE NAME
XXXX G
DELETE?
START: YES      STOP: NO

```

Press START to delete the vehicle or STOP to exit without deleting the vehicle.

NOTE CONCERNING THE DATABASE: We have taken all due care in gathering and entering the information contained in the database. The database data must nevertheless be considered purely indicative; the manufacturer declines any and all responsibility for incorrect data.

DATABASE UPGRADE

Database upgrades are available.

CONVERSION CHART

Ounces (oz) to pounds (lbs):	divide by 16
Pounds (lbs) to ounces (oz):	multiply by 16
Ounces (oz) to grams (g):	multiply by 28.4
Grams (g) to ounces (oz):	divide by 28.4

Pounds (lbs) to kilograms (kg):	divide by 2.205
Kilograms (kg) to pounds (lbs):	multiply by 2.205
Kilograms (kg) to ounces (oz):	multiply by 35.27
Ounces (oz) to kilograms (kg):	multiply by 0.0284