



Mastercool[®] Inc.
"World Class Quality"

OPERATING INSTRUCTIONS

4-WAY BALL VALVE DIGITAL MANIFOLD



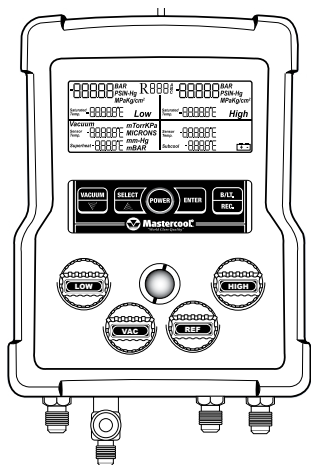

SPECIAL FEATURES

- Low battery indicator
- Displays 63 refrigerants
- Displays corresponding saturation, dew or bubble point temperature for current pressure
- Displays sensor/thermocouple temperature, superheat/subcool temperature and deep vacuum when connected
- Includes back-lit display for easy reading in darker areas
- 9V DC battery with optional AC/DC adapter
- Auto-Off with disabling capability
- Record & store up to 24 hours of data
- Data Logger Software Application
- 4 Way Aluminum block with ball valve design includes 3/8" bore through block for increased flow

SPECIFICATIONS

- Pressure Display: PSI, INHg, Bar, MPa, Kg/cm²
- Deep Vacuum Display: Micron, mBar, KPa, Pa, Torr, mTorr, mmHg
- Temperature Display: °F or °C
- Sensing Resolution: 1 psi (.07 Bar, .007 MPa, .07 Kg/cm²)
- Sensing Accuracy: ±1 psi or 1% of reading (whichever is greater)
- Working Pressure: 0 to 750 psi (52 Bar, 5 MPa, 52 Kg/cm²) (does not display 0-5 psi)
- Proof Pressure: 1000 psi (70 Bar, 7 MPa, 70 Kg/cm²)
(Tolerable pressure without internal damage)
- Refrigerant Temperature Range: -40 to 200°F (-40 to 93°C)
- Operating Temperature: 32 to 122°F (0 to 45°C)
- Temperature Accuracy: ±1°F (±0.5°C) between 32 to 160°F (0 to 71°C)
- Storage Temperature: 10 to 120°F (-12 to 49°C)
- Connections: 1/4" M-Flare and 3/8" M-FL (vacuum hose connection)
- Power: 9V DC battery with optional AC/DC adapter
- Battery Life: 30-36 hours pressure and temperature mode only (continuous use)
25-30 hours vacuum and backlight mode (continuous use)
- Auto-Off: 15 min. with disabling capability



WARNING!!

- Wear Safety Glasses / Wear Gloves
- Keep the manifold in a dry place. Do not allow moisture to enter the unit.
- Do not vent refrigerant into the atmosphere.
- If eyes come in contact with refrigerant, immediately flush with plenty of water. Seek medical attention immediately.
- Do not set manifold on top of an A/C system. This will result in incorrect temperature probe readings.
- **STATIC DISCHARGE:** Climates in some parts of the world are conducive to creating static electric build up (ESD). Your digital manifold has been designed to eliminate the damaging effects of ESD. In some extreme cases, ESD will be apparent on your digital manifold by a lack of response or an inability to turn off the unit. In the rare case that this occurs, simply disconnect the battery, wait 1 minute and reconnect the battery. The digital manifold will "reboot" itself and operate normally once the unit is turned on.
- The display will show zero (0) whenever the measurement falls below the following readings: 3 PSI, 0.2 Kg/cm, 0.2 BAR, 0.02 mPA or 6 in-Hg
- The digital manifold is normally shipped with vacuum and temperature sensors that are calibrated with the companion manifold. In the event the other sensors are provided by another source, please contact Mastercool Inc. for calibration instructions.

BATTERY CARE

When the battery is connected to the unit but not in use it will last six months.

NOTE: In order to prolong the life of the 9V battery;

- keep auto-off function enabled
- if pressure, temperature or deep vacuum is being used for an extended period of time turn the unit off and turn back on again when reading is required. (Allow 30-45 seconds for the correct reading to appear.)





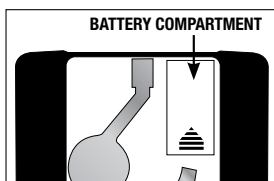

BATTERY INSTALLATION

Remove the battery compartment cover. Make sure to place the battery into the compartment with the correct polarity. Replace battery cover.

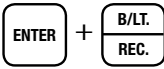

KEYPAD FUNCTIONS

	Turns the unit on and off
--	---------------------------

	Press this key to scroll through and access Refrigerant Menu, Pressure Unit, Temperature Unit, Auto-Off, Vacuum Unit
	Press this key to display vacuum units when vacuum sensor cable is attached
	<ul style="list-style-type: none"> • Press this key to confirm a selection • Press this key for 8-10 seconds to configure a truly zero pressure reading (when there is no pressure in the system)
	<ul style="list-style-type: none"> • Press this key to illuminate the display in darker areas • Press this key for 5 seconds to start and stop the record data mode
	<ul style="list-style-type: none"> • Press these keys simultaneously for 3 seconds to check the status of the recording
	<ul style="list-style-type: none"> • Simultaneously press the enter and b/l/t/rec. and then press power to delete the recorded data from the manifold (record mode must be off)

PRESSURE ADJUSTMENT FOR ELEVATION

For an accurate reading, it is important to adjust the manifold for elevation and barometric pressure. Follow these steps to set the unit for local elevation and barometric readings.

1. Press the **POWER** button to turn the unit ON.
2. Allow 10-15 seconds for unit to initialize. (You will see all characters and units countdown 99999, 88888, 77777...) Once initialization is complete, only pressure and temperature readings will appear.

NOTE: Certain refrigerants do not have a temperature display at a given pressure.

In order to achieve an accurate pressure and temperature reading it is recommended to press and hold the ENTER button for 8 - 10 seconds and then release. Pressure readings will now be truly zero. Due to environmental factors such as elevation, temperature and humidity, you should complete this process each time you turn the unit on to read pressure or vacuum. DO NOT ATTEMPT TO ZERO UNIT OUT WHILE UNDER PRESSURE.



WARNING! If the manifold is connected to a pressure or vacuum source and displays actual readings, do not attempt to zero out the reading by pressing the enter button. This can offset the reading.

SETTING REFRIGERANT, PRESSURE, TEMPERATURE AND AUTO-OFF

- Press the **POWER** button to turn the unit ON. Wait for the unit to initialize [a refrigerant, pressure, temperature or vacuum will be displayed when the unit is ready].

REFRIGERANT MENU

- Press the **SELECT** button to access the **REFRIGERANT MENU**.

Press **SELECT** again to display refrigerant type.

[To scroll through the refrigerants press the **select/↑** or **vacuum/↓** button: R12, R22, R23, R32, R113, R114, R115, R116, R123, R124, R134, R134a, R141B, R142B, R143, R143a, R152a, R290, R401A, R401B, R404A, R407A, R407B, R407C, R407D, R407F, R409A, R410A, R410B, R411A, R411B, R412A, R413A, R414A, R414B, R417A, R422A, R422B, R422C, R422D, R427A, R434A, R437A, R438A, R441A, R448A, R449A, R452A, R455A, R501, R502, R503, R504, R507A, R508B, R509A, R600, R600A, R601, R601A, R744]

Press **ENTER** to confirm the desired refrigerant.

PRESSURE UNIT

- Next the **PRESSURE UNIT** will display.
Press the **SELECT** button to change the pressure unit. Press **ENTER** to confirm.

TEMPERATURE UNIT

- Next the **TEMPERATURE UNIT** will display.
Press the **SELECT** button to either °F or °C. Press **ENTER** to confirm.

AUTO-OFF

- Next **AUTO-OFF** will display.
Press the **SELECT** button to disable Auto-Off [auto-off will clear from the display.]

If the auto-off feature is displayed the manifold will shut down after 15 minutes. Press the **ON/OFF** button to turn the unit back on and allow 15-20 seconds to initialize.

NOTE: It is recommended to keep the auto-off feature enabled to save the life of the battery.

SETTING VACUUM

- Connect the vacuum sensor cable to the manifold and turn the unit on.
- Press the **VACUUM** button. This will phase out the temperature display and only show the vacuum units.
- Press the **SELECT** button until the desired vacuum unit is displayed.
- Press **ENTER** to confirm.
- The vacuum display will automatically go off after 15 minutes.
Press the **ON/OFF** button and **VACUUM** button to turn the unit on. Allow 30-45 seconds for the sensor to warm up and the correct vacuum reading to appear.
(If pressure, temperature or deep vacuum is being used for an extended period of time turn the unit off and turn back on again when reading is required.)

Fig. A

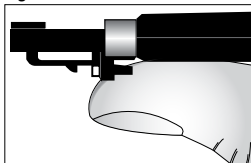

NOTE: (SEE FIG. A) To disconnect the vacuum sensor cable be sure to press the release latch under the connector cable. Pulling on the cable without disengaging the latch will cause damage and is not replaceable under warranty.

4-WAY DIGITAL VALVE BODY CONFIGURATION

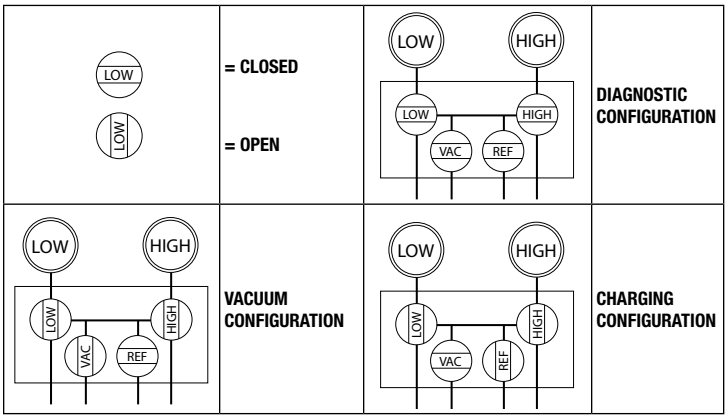

IMPORTANT NOTES FOR SERVICING AC/R SYSTEM

A system that has been opened or one that is found to be excessively low on refrigerant pressure as a result of a leak, must be fully evacuated by means of recovery/recycling and deep vacuum. A system that has been evacuated must be repaired, leak tested and evacuated again before charging.

DIAGNOSING THE SYSTEM PRESSURE AND TEMPERATURE

1. Make sure all valves on the manifold are closed.
2. Connect the blue and red hose from the low and high side of the manifold to the system.
3. Start the system and allow some time for the true pressure reading on the manifold to appear and stabilize.

CHARGING

1. Verify that all valves on the manifold are shut completely.
2. Turn the A/C system and manifold ON.
3. Connect the other end of the yellow hose to Refrigerant Gas supply.
4. Open refrigerant valve and low side valve slowly and start charging. (Follow refrigerant manufacturer's instructions for proper dispensing. Use an electronic scale for accurate charging (Mastercool #98210-A))
5. When charging is finished, close the valve on the tank and allow some time for the refrigerant to be evacuated from the hoses and manifold.
6. Close the low side & refrigerant valve and disconnect the hose(s) from the system.

VACUUM GAUGE OPERATION (SEE FIG.B)

- Press the **POWER** button to turn the unit ON. Allow 10 seconds for the unit to initialize.
 - Close all valves.
 - Connect the high side and low side hoses to the system and the yellow or black hose to the vacuum pump.
 - Connect the vacuum cable to the manifold. Connect the other end of the vacuum gauge to the system. (An additional TEE fitting (Mastercool #99333) or an isolation valve may be required.)
- Press the **VACUUM** button and select the desired unit.
- Press **ENTER** to confirm.

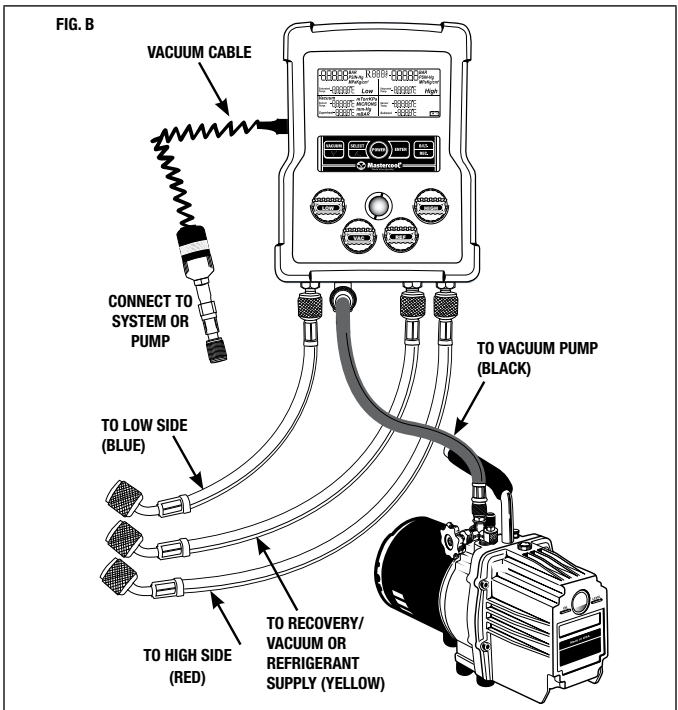

- Start the vacuum pump and open high, low and vacuum valves. The vacuum countdown will start from atmospheric pressure (29.92). Depending on the size of the system, the lines on the LCD display will disappear one by one. Once all lines have disappeared, the numerical reading will appear on the LCD. The numbers descend from 25000 MICRONS or corresponding units.

NOTE: The unit will shut down after 15 minutes automatically. Press the **POWER** button again. Allow 30-45 seconds for initializing and the correct vacuum reading to appear. Once the target vacuum is reached, close the vacuum valve and disconnect the vacuum gauge port from the system. Press the **POWER** button to turn the unit off. (If **pressure, temperature or deep vacuum is being used for an extended period of time turn the unit off and turn back on again when reading is required.**)



WARNING!! Never stop the vacuum pump unless the vacuum gauge is disconnected. Failure to do so may cause oil to enter the sensor chamber.

IMPORTANT: When checking a system for leaks under high vacuum (less than 1000 microns), connect the vacuum gauge directly to the system. If additional connections are required use copper tubing (do not use rubber hoses) and high vacuum shut-off valves. Standard hoses and manifold gauge set shut-off valves may have a small amount of leakage under high vacuum. When initiating a high vacuum test, the vacuum gauge reading may “drift” higher until the system has equalized. After this short stabilization period (5 minutes) the vacuum reading should hold steady. An upward “drift” of the vacuum gauge reading may indicate a leaking system.

MEASURING ACTUAL SUPERHEAT AND SUBCOOLING (SEE FIG. C)

Superheat is the difference between the actual temperature (**sensor temperature**) of the refrigerant (gas) as it leaves the evaporator and the boiling point temperature of the refrigerant in the evaporator coil (**saturated temperature**). After boiling, the refrigerant continues to warm up. The number of degrees it “warmed up” after boiling is called the **superheat**. Under worst-case conditions (low load for fixed orifice systems), the refrigerant in the evaporator boils off near the end of the evaporator coil. To make sure liquid doesn’t enter the compressor under the worst case condition, the AC manufacturers publish charts. The charts indicate what the superheat should be at a given indoor wet bulb measurement and outdoor air temperature. Measuring superheat is your best indication on a fixed orifice system of the proper refrigerant charge and operating conditions. If everything else is working properly and the actual superheat is too high, add refrigerant. If it’s too low, remove refrigerant.

Subcooling is the difference between the boiling point of the refrigerant in the condenser (**saturated temperature**) and the actual temperature (**sensor temperature**) of the refrigerant as it leaves the condenser. The degrees that the refrigerant “cools down” below the boiling point is the sub-cooling. Under worst case scenario low load for thermostatic expansion valve systems (TXV) the subcooling will continue to rise. If the subcooling rises too high, liquid may be backed into the compressor causing damage and failure.

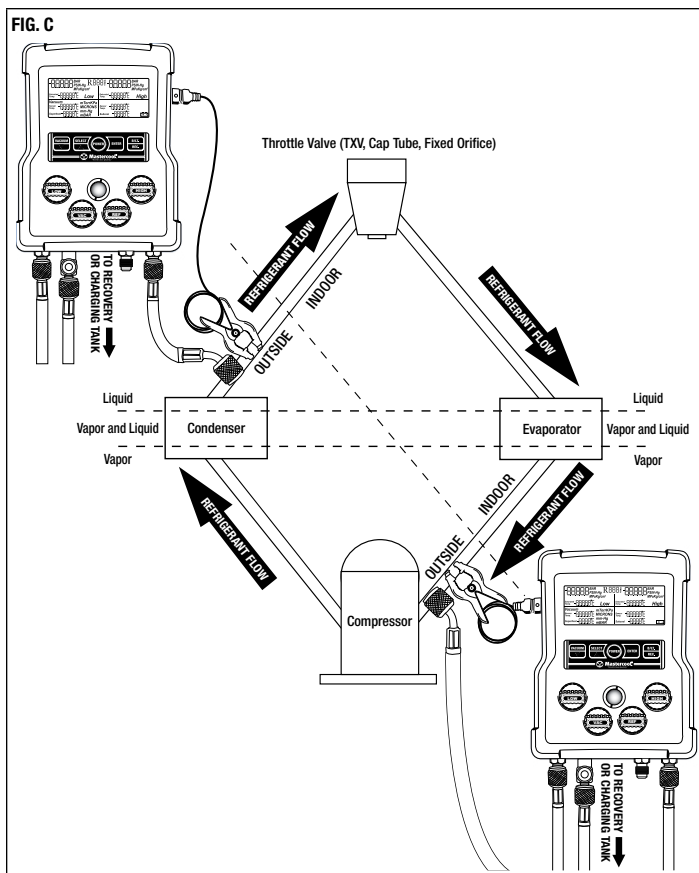

On TXV systems, the subcooling is the best indication of the state of the charge in the refrigerant system since these systems are designed to maintain constant superheat. Properly charging a system ensures maximum efficiency and longer equipment life.



Use caution whenever working with electricity and high-pressure liquid or gas. Always wear safety glasses.

Follow all instructions provided with equipment being serviced or installed.

TARGET SUPERHEAT AND SUBCOOLING

Follow all equipment manufacturer's specifications, warnings and suggestions. To determine the target superheat (fixed orifice system) or subcooling (charts vary dramatically from one system to another), you will typically need three things. Outdoor dry bulb (outdoor air temperature), indoor wet bulb, and the manufacturers target superheat chart or subcooling chart.

You can use Mastercool part number 52232 Humidity Temperature Meter for both indoor wet bulb and outdoor dry bulb. (Refer to diagram.)

GENERIC TARGET SUPERHEAT & SUBCOOLING CHARTS*

*The required superheat chart is an example of a generic superheat chart of a typical fixed orifice, split residential system. The required subcooling chart is an example of a typical chart for a TXV, split residential system. These charts should not be used for charging. They are only examples to show what the manufacturer's charts may look like. Follow all manufacturer's indications, instructions and warnings above those in this manual.

The indoor wet bulb measurement should be taken as close to the evaporator coil inlet as possible. The outdoor dry bulb reading should be taken as close to the condenser air inlet as possible.

REQUIRED SUBCOOLING °F										
Wet Bulb Temperature °F										
Dry Bulb Temperature °F	57	59	61	63	65	67	69	71	73	
75	25	24	23	22	21	20	19	18	17	
80	24	23	22	21	20	19	18	17	15	
85	23	22	21	20	19	18	16	15	14	
90	22	21	20	19	18	16	15	14	12	
95	21	20	19	18	17	15	13	12	10	
100	20	19	18	17	15	13	12	10	8	
105	19	18	17	16	14	12	10	8	6	
110	17	16	15	13	12	10	8	6	4	
115	15	14	13	12	10	8	6	4	2	

REQUIRED SUPERHEAT °F														
Wet Bulb Temperature °F														
Dry Bulb Temperature °F	50	52	54	56	58	60	62	64	66	68	70	72	74	76
55	9	12	14	17	20	23	26	29	32	35	37	40	42	45
60	7	10	12	15	18	21	24	27	30	33	35	38	40	43
65		6	10	13	16	19	21	24	27	30	33	36	38	41
70			7	10	13	16	19	21	24	27	30	33	36	39
75				6	9	12	15	19	21	24	28	31	34	37
80					5	8	12	15	18	21	25	28	31	35
85							8	12	15	19	22	26	30	33
90							5	8	13	16	20	24	27	31
95								5	10	14	18	22	25	29
100									8	12	15	20	23	27
105									5	9	13	17	22	26
110										6	11	15	20	25
115											8	14	18	23

RECORDING FEATURES THROUGH THE MANIFOLD

- The manifold has the ability to record and store up to 24 hours of data and track up to 15 job sequences.

NOTE: No single recording can be longer than 8 hours.

- Data that is stored in the manifold can be downloaded into Mastercool's Data Logger Program for analysis at a later time. To download the data please refer to the Data Logger Program Instructions.
- To see data outputted in "real time" please follow the instructions provided with the Mastercool Data Logger Software.

NOTE: When in recording mode the Auto-Off feature is automatically disabled.

RECORDING DATA

Turn the manifold ON and after the unit is initialized and the sequencing stops, you may enter the record data mode

- RECORD data by pressing the BLT/REC button for 5 seconds until JOB1 appears on the screen.

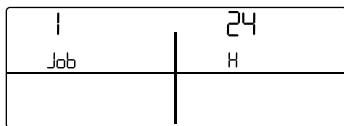

NOTE: The amount of recording time left will display in the right hand corner of the LCD. Example: 24 hours

- Release the BLT/REC buttons and the letter R will begin to flash in the main display. This remains flashing the entire time the manifold is recording.

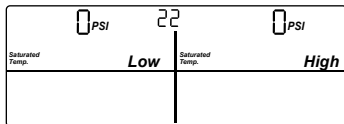

CHECKING THE STATUS OF THE RECORDING

- Press the ENTER + BLT/REC button for 3 seconds
- In RECORDING MODE the status will display the Job # you are currently recording and the amount of recording time that you have left

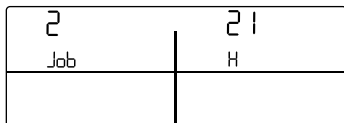

- In REGULAR MODE the status will display the total number of jobs recorded and that the status of recording is OFF.

	R22	OFF
Job		OFF

NOTE: When the manifold is in the last hour of recording and the user performs a check status command the 0 that will be displayed shall be flashing to indicate that the recording capacity is approaching the limit.

EXITING RECORDING MODE

Once sufficient data has been recorded exit the recording mode by pressing and holding the BLT/REC button for 5 seconds. OFF will appear in the display and then you can release the button.

	R22	OFF
Job		OFF

NOTE: Powering OFF the manifold will also turn off the recording mode.

DELETING RECORDED DATA

NOTE: When the delete recorded data command is performed all data will be erased from the manifold.

NOTE: The data will not delete if you are in recording mode. Exit record mode in order to delete the data.

- Once the data in the manifold is no longer of use delete the data by simultaneously holding down the ENTER + BLT/REC buttons and then pressing the POWER button until the default screen appears on the LCD.

CLEANING THE SENSOR (SEE FIG. D)

Observe the gasket after each vacuum. If oil is present, it is possible that there is a presence of oil in the sensor chamber.

Follow these instructions:

1. Disconnect the sensor chamber from the socket.
2. Remove the gasket & depressor from the assembly to clean.
3. Clean the gasket. Rinse the sensor chamber with acetone. Repeat until the oil is completely removed. Allow 2 – 4 hours for all of the parts to dry.
4. Reassemble all of the parts and check the unit.

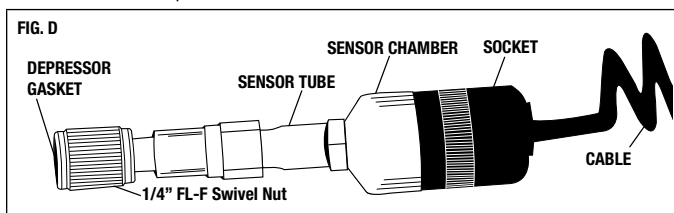

PARTS AND ACCESSORY LIST

42010	Gasket for 1/4" FL
42014	Depressor
85511	3/8" Gasket for Black Hose
99103-SENSOR	Sensor
99903-BLOCK	Block for 99903
99903-PC	PC Board for 99903
99903-PB	Plastic Box
99903-RB	Rubber Boot
98061-SENSOR	Sensor Assembly
98062-001	Vacuum Sensor Cable (only)
99332	1/8 NPT x 1/4 F Flare Swivel Adapter
99903-USB	USB Cable

OPTIONAL ACCESSORIES

52232	Humidity Temperature Meter
52336	Clamp-On Thermocouple (3 ft)
52337	Clamp-On Thermocouple (10 ft)
98062	Complete Vacuum Sensor & Cable Assembly
98210-A	Accu-Charge II Electronic Refrigerant Scale
99333	1/4 FL-M x 1/4 FL-M x 1/4 FL-F Tee
99334-110	110V AC/DC Adapter
99334-220	220V AC/DC Adapter (schuko plug)

⚠ WARNING: This product can expose you to chemicals including lead, which is known to the State of California to cause cancer and birth defects or other reproductive harm.