

- ▲ Same strength as a standard LSR, increased clearance.
- ▲ Fits any Merritt LSR, Dyna-Light or Diamond Back. (8 Models)
- ▲ Drill pattern mounting instruction attached to the foot for ease of installation.
- ▲ Great for storage, one door, two door and full three door enclosures are available. Internal shelves and chain hangers are popular options. Keep your storage items out of the weather and out of sight.
- ▲ Fits all standard truck frame widths.
- ▲ Special tray options are available to maximize trailer swing clearance. (See option order information)
- ▲ Stocked in most Merritt warehouse locations.

## **SHORT FOOT LSR OPTION**



# NORTHERN-LIGHT LSR

ORDER INFORMATION

Order #	Description/Dimensions H x W	Shipping Wt.	Maximum Static Load Resistance:* Lbs.
3700	Northern-Light LSR 68 x 84	302	25,500 Lbs.
3240	Northern-Light Clamp Kit (14" U-bolts)	31	



Three LED stop/turn lights in each corner.



Three LED Marker lights centered

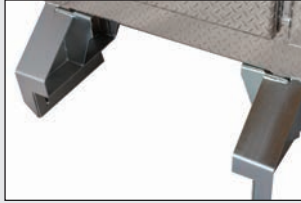

The foot is made of steel and is Zinc plated for anti-rust and a finished look.



Center compartment with 2 shelves



Foot assembly with the cut outs for the U-bolts to mount through and also, the pre-drilled mounting holes for side mounting. Your choice!



Inside view of the foot. Please note the design to achieve the strength needed



Chain hangers in each side compartment

- ▲ Northern-Light LSR's have been tested by an independent engineering firm for maximum uniformly distributed static load.
- ▲ Must be Installed to Merritt Specifications with a Merritt Mounting Kit.
- ▲ Mounting Kits not Included. Reference Mounting Kit - Page 3A and 3B
- ▲ Merritt LSR's are not to be used in conjunction with log trailers or pole trailers.

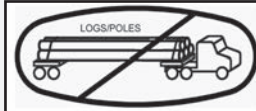

## WARNING LIMITED RESISTANCE TEST

Each model LSR has been designed and tested in conjunction with a Merritt Mounting Kit. Each model LSR has been tested to resist a maximum uniformly distributed static load as stated above.

Each model LSR offers limited resistance against impact. Merritt Equipment Co. makes no representations, implied or otherwise, except for the uniformly distributed static load resistance test as stated above. Any load or force in excess of the uniformly distributed static load resistance test may result in failure of this product which can result in serious injury or death.

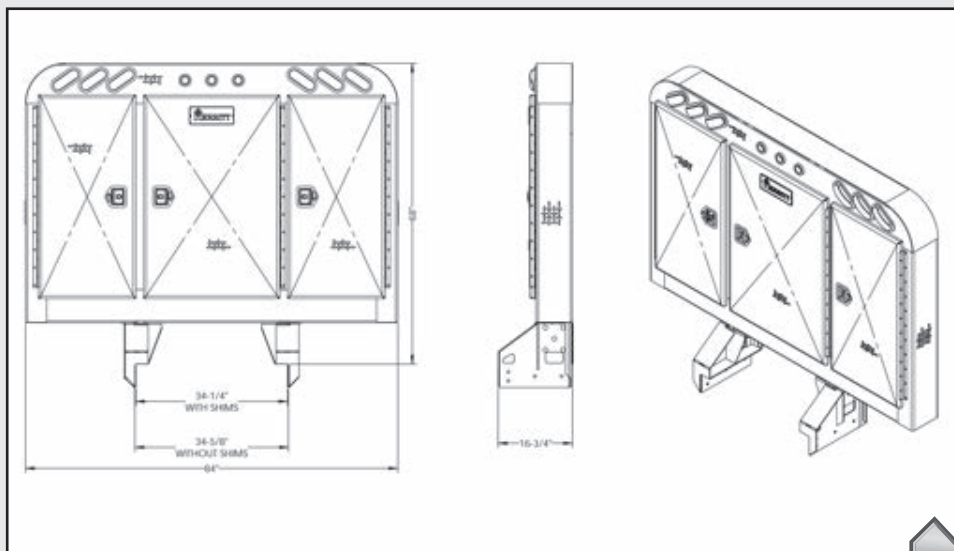

No rear Beams. You can get the unit closer to the cab than a normal LSR.

Models and/or Specifications Subject to Change Without Notice.

F.O.B. - Atlanta GA, Birmingham AL, Dallas TX, Henderson CO, Houston TX, Minneapolis MN, Nashville TN, Pittsburgh PA, Sacramento CA, Kansas City KS, Calgary, AB (Canada), Toronto, ON (Canada)

