

## USER'S MANUAL



Specifications:  
Reservoir Capacity (w/ pump): 5 quarts/1.2 gallons/4.5 liters  
Maximum Pressure: 25 psi/1.7 bar/170 kPa

It is the responsibility of the user of this equipment to read this user's manual entirely, and understand the safe and proper use and application of this equipment.

---

## TABLE OF CONTENTS

Service Parts & Accessories .....	3
Principal of Operation.....	4
Applications .....	4
Precautions .....	4
Instructions for Use .....	5
Fluid Dispensing.....	5
Pressure Brake Bleeding .....	6
Refilling Sealed Automatic Transmissions.....	7
Spanish .....	8
French .....	15
German.....	22

# SERVICE PARTS & ACCESSORIES

SERVICE KITS		
Ref. No.	Part No.	Description
1	801230	Lid w/ Pump Assembly
2	801229	1-gallon Reservoir
3	801233	Lid Gasket
4	801234	Pressure Gauge
5	822561	Pump Handle

## STANDARD ACCESSORIES



## OPTIONAL ACCESSORIES

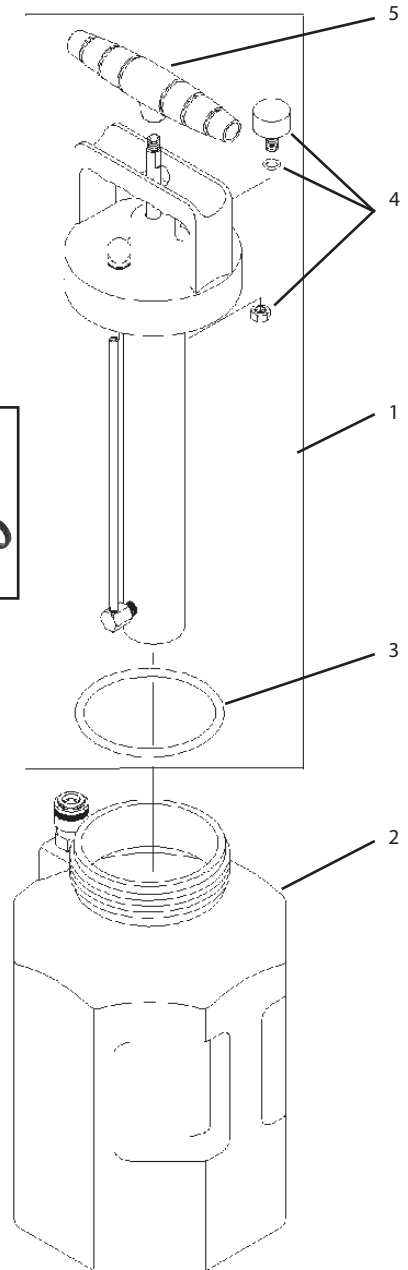

---

## PRINCIPAL OF OPERATION

This equipment is designed and intended for use as a means to dispense fluid. It utilizes a manual pressure pump to build pressure in the reservoir. The pressure forces fluid to dispense out of the reservoir through a fluid pickup tube. The output of the fluid pickup tube is connected to a quick-change coupler, to which a variety of accessories can be attached to control or direct the flow of fluid according to the intended application.

The equipment should never be operated above a safe level of pressure depending on the application. A gauge is installed to indicate the pressure in the reservoir, and should be observed regularly to ensure the pressure remains at or below what is recommended for the application.

### Applications

This equipment is intended for filling reservoirs with fluids such as engine coolant, motor oil, or wiper, automatic transmission, brake or power steering fluid. However, with the proper accessories it can safely be used to pressure bleed hydraulic brake or clutch systems, or refill or top-off sealed automatic transmissions.

### Precautions

This equipment is designed for servicing a variety of vehicles in a safe, convenient manner. However, differences in vehicle makes and models may make it impossible to use this equipment as it is intended. Do not attempt to force the use of this equipment on an application for which it is not designed to perform.

The procedures documented in this manual are to serve as guidelines for the use of this equipment. In addition to these guidelines, always follow the manufacturer's recommended procedures when servicing each unique vehicle.

The use of this equipment is simple and straightforward if you follow the instructions. However, always keep in mind that you are working with a system that may be under pressure, with fluid that is just waiting to be expelled. When operating this equipment, use common sense, and always stop to think before disconnecting a hose or other component.

- This equipment is intended only for professional use by personnel trained in performing the service functions for which it is has been designed.
- Read carefully and understand all instructions prior to using this equipment.
- Always wear eye protection and proper clothing when operating this equipment
- Do not attempt to modify the pressure relief valve to alter its performance. If pressure in the reservoir ever exceeds 23 psi (1.6 bar), return it to an authorized service center for repair or replacement.
- Some fluids, including brake fluid, are corrosive, and proper care should be taken to protect painted surfaces and skin from exposure.
- Do not use this equipment with gasoline or other flammable liquids, or with fluids at temperatures above 175° Fahrenheit (80° Celsius).
- Consult and follow the vehicle manufacturer's recommended procedure when using this equipment to perform automotive service.

---

## INSTRUCTIONS FOR USE

### Fluid Dispensing

1. Unscrew the lid w/ pump from the reservoir, and fill to desired level with clean fluid.

Note: There are two scales of volume on the reservoir. One scale indicates the volume when the lid w/ pump is removed and one when the lid w/ pump is installed. Be sure to note the appropriate scale.

CAUTION: If fluid is added above the MAX FILL line, the reservoir will overflow when the lid w/ pump is installed.

2. Reinstall the lid w/ pump onto the reservoir.
3. Connect the fluid dispensing hose or other accessory to the quick-connect coupler extending from the reservoir. Ensure the coupler sleeve snaps forward to lock the connection.

Note: Depending on the application, the shutoff valve installed in the fluid dispensing hose may be left open or closed. If left open, fluid will begin to flow as soon as the pump is operated. If closed, pressure will build in the reservoir as indicated on the gauge.

4. While observing the pressure gauge, operate the pump to build pressure in the reservoir to the desired level, or until the desired amount of fluid has been dispensed.

Note: A built-in pressure relief valve is designed to open and maintain maximum pressure between 17 and 23 psi (1.2 and 1.6 bar).

Continual operation of the pump is not required to maintain fluid flow. Fluid will continue to flow as long as there is pressure in the reservoir and the shutoff valve is open.

WARNING: Do not exceed 25 psi (1.7 bar) pressure in the reservoir. The relief valve should prevent this, but if it fails and the pressure exceeds 25 psi, immediately discontinue use and send the unit to an authorized service center for repair or replacement.

5. Once the proper amount of fluid has been dispensed, close the shutoff valve and bleed off the pressure by tilting the pressure relief knob located on the lid.

6. Depending on the type of fluid and future intended use, you may store the remaining fluid from the reservoir. Otherwise empty the reservoir, clean it with denatured alcohol or a common household cleaner, and store it properly.

---

## PRESSURE BRAKE BLEEDING

The Mityvac Fluid Dispensing System is appropriate for use as a pressure bleeder for hydraulic brake and clutch systems. Additional accessories and adapters may be required and are available from Mityvac for performing this function.

**WARNING:** Hydraulic/brake fluid is hazardous and corrosive. Take precautions to protect painted surfaces and skin from exposure, and read and follow the fluid manufacturer's warnings and instructions.

1. Park the car, set the parking brake, and turn off the engine.
2. Open and secure the hood.
3. Locate the brake or clutch master cylinder and remove the cap.
4. Extract as much used hydraulic fluid from the master cylinder reservoir as possible, and refill it with new fluid.
5. Select the appropriate master cylinder pressure bleed adapter and install it securely onto the master cylinder reservoir.
6. Before adding fluid to the Dispenser, connect the fluid dispensing hose to the female quick-connect coupler extending from the reservoir. Ensure the coupler sleeve snaps forward to lock the connection.
7. Connect the other end of the fluid dispensing hose to the male quick-connect coupler on the master cylinder pressure bleed adapter. Ensure the coupler sleeve snaps forward to lock the connection.
8. Ensure the shutoff valve is open, and operate the manual pump to pressurize the system to 10 psi (0.7 bar).
9. Watch the pressure gauge to ensure there are no leaks. If the pressure drops, relieve the remaining pressure in the system by tilting the pressure relief knob located on the lid, remove and retighten the lid from the dispensing reservoir and the adapter on the master cylinder reservoir, and recheck the system for leaks.

**WARNING:** Serious injury and/or equipment damage can occur if the lid is removed from the dispensing unit or the adapter from the master cylinder, without first relieving the system pressure.

10. Once you've proven all connections are secure and the master cylinder adapter does not leak,

remove the lid w/ pump from the dispensing unit and add up to 2 quarts (2 liters) of a manufacturer's recommended new hydraulic fluid from a sealed container.

11. Reinstall the lid w/ pump and tighten it securely.
12. Consult a service manual to determine the recommended bleed pressure and the proper bleeding sequence for the vehicle being serviced.
13. Observing the pressure gauge, operate the pressure pump to achieve the recommended pressure.
14. Connect the bleed reservoir to the bleed screw of the first cylinder to be bled.
15. Open the bleed screw. Allow fluid to flow out until only clear new fluid with no visible air bubbles is streaming from the screw, and then re-tighten the bleed screw to the manufacturer's recommended torque.
16. Perform the same procedure on all remaining bleed screws. Operate the pressure pump as required to maintain adequate pressure.

**Note:** Do not allow the dispensing unit and master cylinder reservoir to run dry. Use the pressure relief valve to relieve the pressure and add new fluid if necessary.

17. Once bleeding is complete, relieve the pressure in the reservoir and master cylinder by tilting the pressure relief knob located on the lid of the dispensing unit.
18. Close the fluid dispensing hose shutoff valve, and carefully remove the adapter from the master cylinder, being careful not spill any brake fluid.
19. Extract excess fluid or top-off the master cylinder as required, and replace the cap.
20. Dispose of any hydraulic fluid remaining in the Dispenser. Do not store hydraulic fluid in the reservoir. Clean the dispensing unit with denatured alcohol and store it properly.
21. Test the brake or clutch system for leaks before driving the car.

The Mityvac Fluid Dispensing System is appropriate for use to refill or top-off sealed automatic transmissions. Additional accessories and adapters may be required and are available from Mityvac for performing this function.

---

## REFILLING SEALED AUTOMATIC TRANSMISSIONS

1. Unscrew the lid w/ pump from the reservoir, and fill to desired level with new vehicle manufacturer's recommended transmission fluid.

**CAUTION:** Lifetime "sealed" transmissions require the use of special manufacturer recommended fluids. Use of any other fluids may cause severe damage to the transmission and void the manufacturer's warranty.

**Note:** There are two scales of volume on the reservoir. One scale indicates the volume when the lid w/ pump is removed and one when the lid w/ pump is installed. Be sure to note the appropriate scale.

**CAUTION:** If fluid is added above the MAX FILL line, the reservoir will overflow when the lid w/ pump is installed.

2. Reinstall the lid w/ pump onto the reservoir.
3. Connect the fluid dispensing hose to the reservoir using the quick-connect coupler. Ensure the coupler sleeve snaps forward to lock the connection.  
**Note:** The shutoff valve installed in the fluid dispensing hose may be left open or closed. If left open, fluid will begin to flow as soon as the pump is operated. If closed, pressure will build in the reservoir as indicated on the gauge.
4. Select the appropriate ATF refill adapter for the application and connect it to the output of the fluid dispensing hose.

5. Insert or connect the ATF refill adapter to the transmission.
6. While observing the pressure gauge, operate the pump to build pressure in the reservoir to the desired level, or until the proper amount of fluid has been dispensed.

**Note:** Check the vehicle's service manual to determine the proper method to check the transmission fluid level. Failure to follow the manufacturer's recommended procedure could result in under- or over-filling the transmission, causing severe transmission damage.

The pressure relief valve is designed to open and maintain maximum pressure between 17 and 23 psi (1.2 and 1.6 bar).

Continual operation of the pump is not required to maintain fluid flow. Fluid will continue to flow as long as there is pressure in the reservoir and the shutoff valve is open.

**WARNING:** Do not exceed 25 psi (1.7 bar) pressure in the reservoir. The relief valve should prevent this, but if it fails and the pressure exceeds 25 psi, immediately discontinue use and send the unit to an authorized service center for repair or replacement.

7. Once the proper amount of fluid has been dispensed, close the shutoff valve on the fluid dispensing hose and bleed off the pressure by tilting the pressure relief knob located on the lid.
8. Depending on the type of fluid and future intended use, store or empty the remaining fluid from the reservoir.
9. Clean the unit with denatured alcohol or common household cleaners, and store it properly.